

### DIMENSIONS

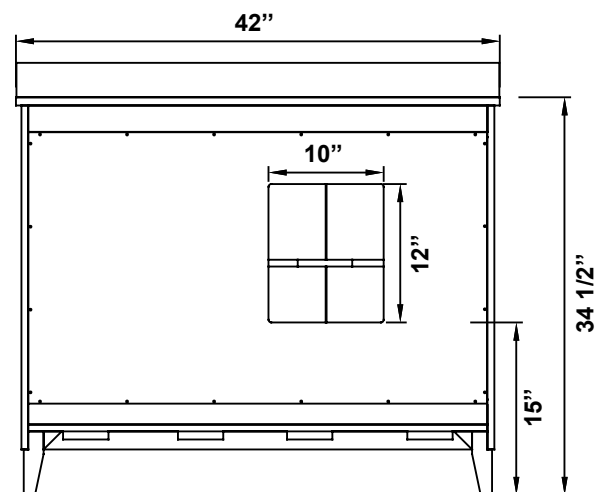

**Questions, problems, need help?**  
Before returning to your retailer, contact our customer service department with the QR code :

8 a.m. - 5 p.m., EST, Monday - Friday

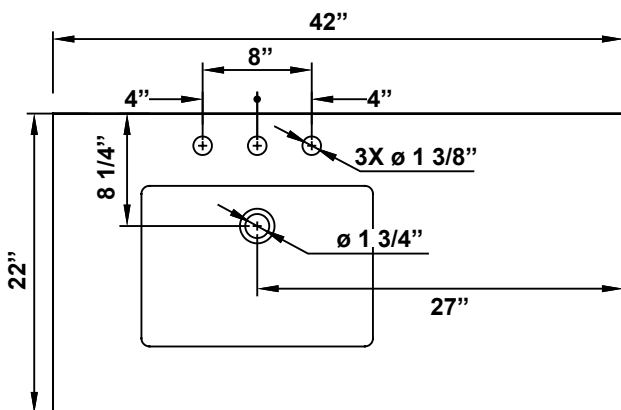

1-866-839-2888

# PARTS LIST

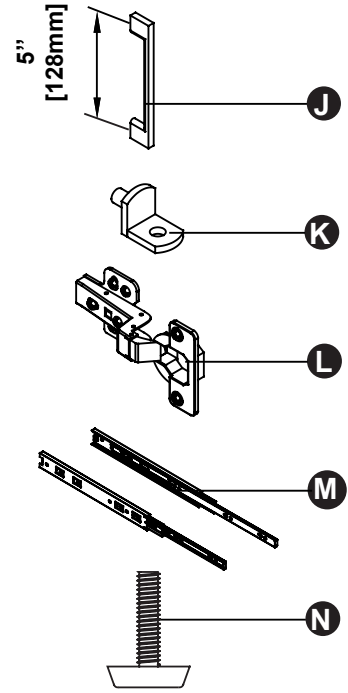
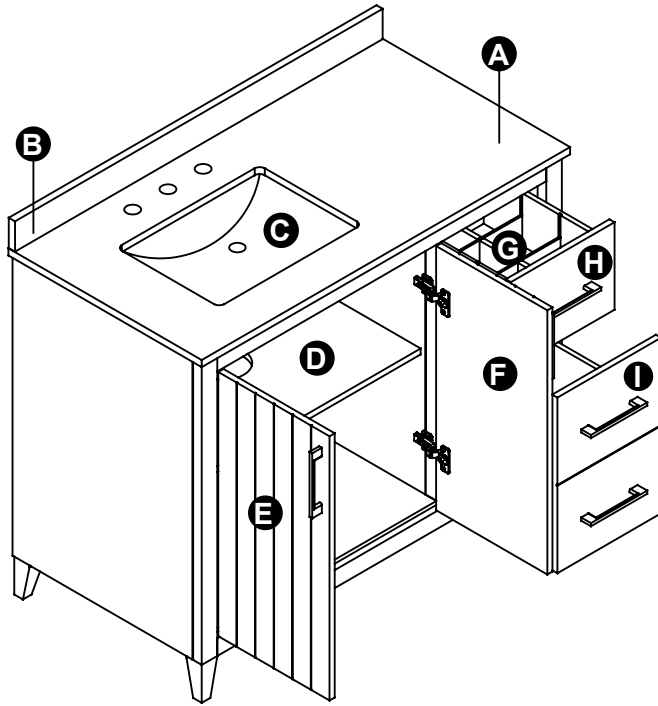

ITEM #	DESCRIPTION	QUANTITY	REPLACEMENT PART CODE
A	Countertop	1	Not Available
B	Backsplash	1	99VBS-7K98R397
C	Basin	1	99VBA2090-EV
D	Adjustable shelf	1	99VDO-8LU1NJ5K-EV
E	Door (left)	1	99VDO-U36404X5-EV
F	Door (right)	1	99VDO-037JR37O-EV
G	Drawer dividers (pre-installed)	1	99VDO-P130L34K-EV
H	Top drawer with dividers	1	99VDO-B6VYV325-EV
I	Double depth drawer	1	99VDO-629738O5-EV
J	Handle	5	99VHA-EPD2CGIB-EV
K	Shelf holder	4	99VHW2172-EV
L	Hinge	4	99VHI-7W1Q3L8V
M	Drawer glides	2	99VGL-1BTIW81F
N	Adjustable leveling feet	4	99VLE2069-EV

## TOOLS REQUIRED (not supplied)



Pencil



Screwdriver



Level



Cutter



Silicone

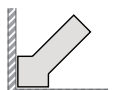

Caulk finishing tool

# 1 Unpacking the countertop

- 1.1. Lift up the countertop (A) from the vanity base and place it on a protective floor covering such as cardboard to prevent damage.
- 1.2. Remove the protective foam from the vanity cabinet.

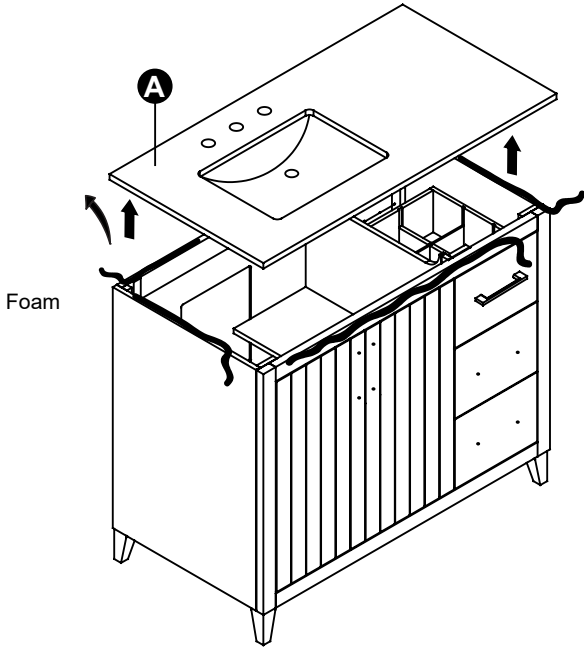

# 2 Attaching the countertop

- 2.1. Apply silicone (sold separately) onto the vanity base where the countertop (A) will be placed.
- 2.2. Replace the countertop (A) on top of the vanity base.

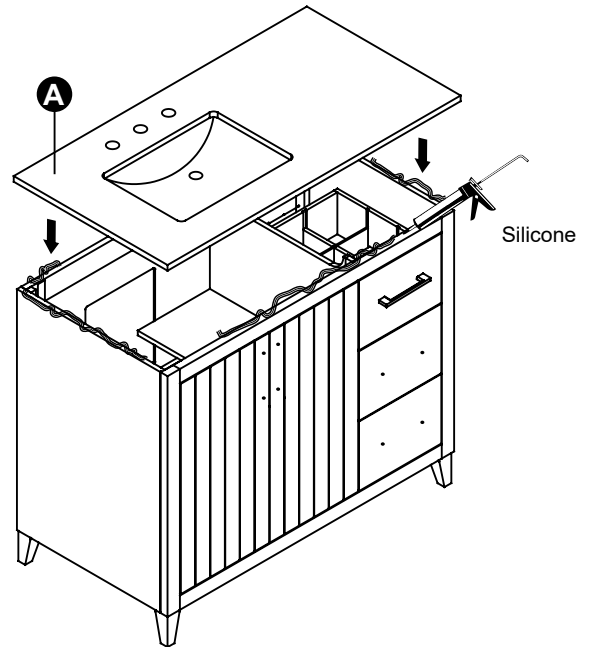

# 3 Reversing the handles

- 3.1. Remove the handles (J) from the pre-installed positions using a screwdriver, and relocate them to the exterior pre-drilled holes located on the doors and double depth drawer.
- 3.2. Use the same screws to secure the handles (J).

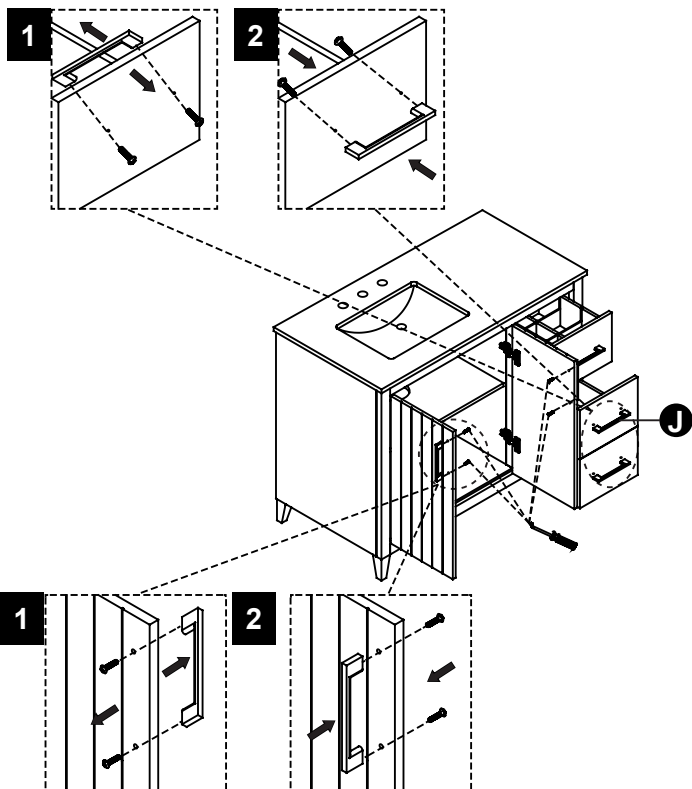

# 4 Countertop sealing

- 4.1. Apply silicone sealant along the edge underneath the countertop where it meets the cabinet top trim.

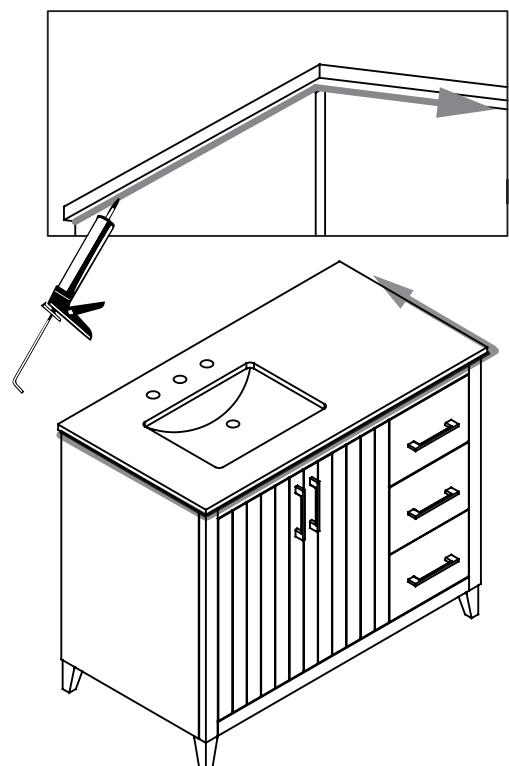

## 5 Attaching the backsplash

- 5.1. Wipe off the area on the top of the countertop (A) where the backsplash (B) will sit using a clean cloth.
- 5.2. Apply a line of silicone onto the unfinished bottom side of the backsplash (B).
- 5.3. Align the backsplash (B) with the back edge. Slowly lower it onto the countertop (A) and gently press to adhere.

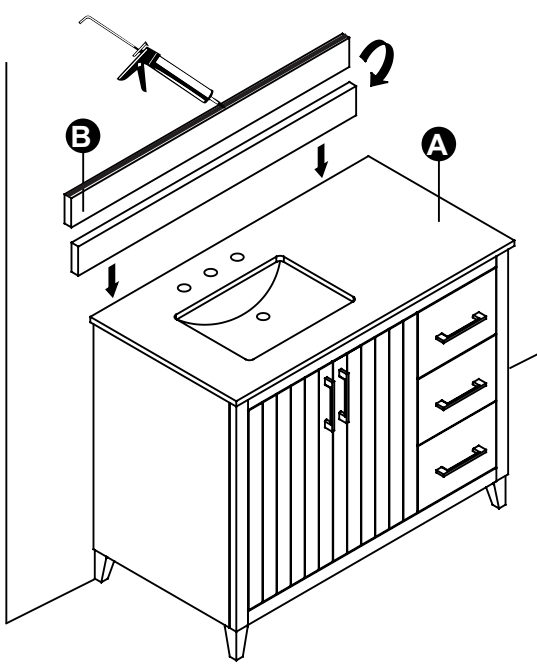

## 6 Completing the assembly

- 6.1. Wipe away any seeping silicone from underneath the countertop (A) and backsplash (B) with a caulk finishing tool.

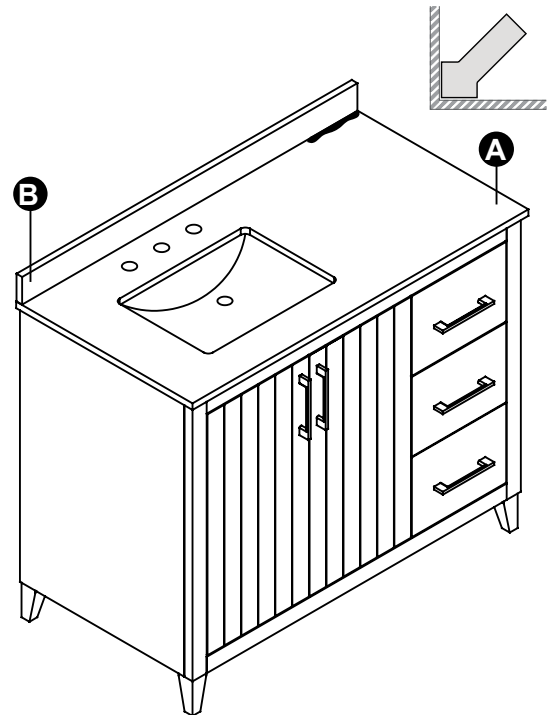

## 7 Drying

- 7.1. Installation Complete - Allow any silicone applied to the vanity to dry for 24 hours before use.

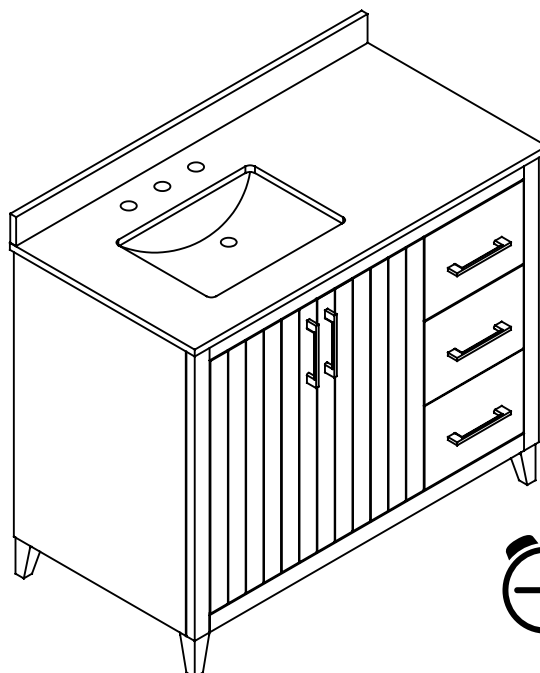

## 1 How To Remove The Drawer

\*If necessary, each drawer is designed to be removed or replaced:

- 1.1. Pull out the drawer until the lock pins located at the sides of the drawer are easy to reach. Pull up the lock pin on the left side of the drawer, and push it down on the right side to release the drawer.
- 1.2. Pull out the drawer to remove it.

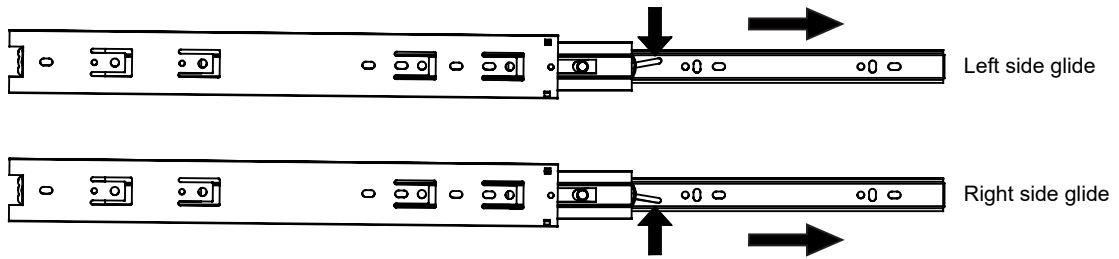

## 2 How To Install The Drawer

- 2.1. Insert the drawer into the glides. Completely slide in the drawer, then the drawer will automatically click in place.

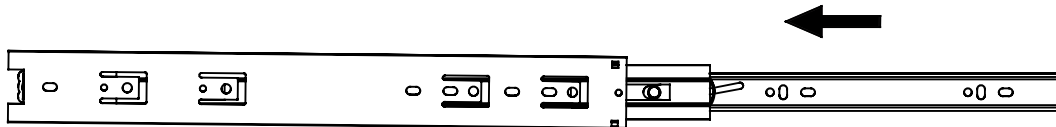

# 1 How To Remove The Shelf

Each shelf can be removed or repositioned to create more space:

- 1.1. Uninstall the screws and remove the shelf (D).
- 1.2. Pull out the shelf holders (K).

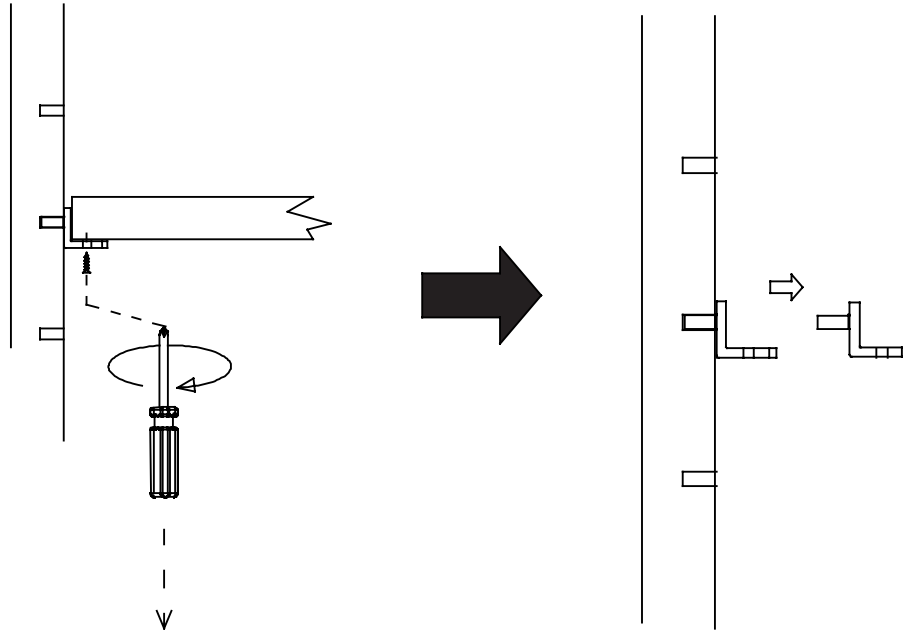

# 2 How To Install The Shelf

There are multiple positions to install the shelf to help you have the desired space. To change spacing, remove the shelf, and adjust the pins as desired.

- 2.1. Select your desired location and push the shelf holder (K) into place on both the right and left sides.
- 2.2. Place the shelf (D) onto the shelf holders (K). Make sure the shelf is properly level, and use screws to secure the shelf (D) to the shelf holder (K).

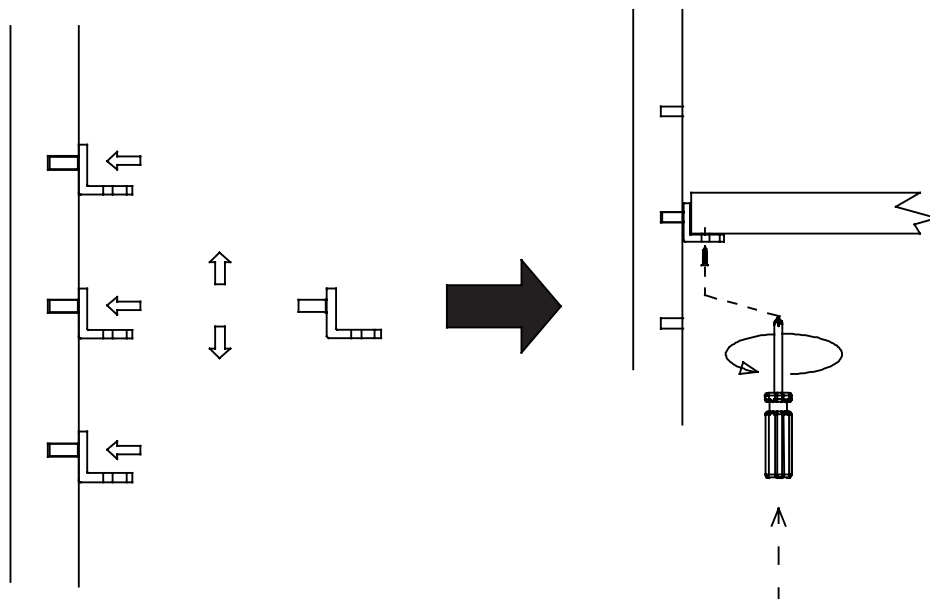

# 1 Door's in and out adjustment

Each door will come pre-installed on the cabinet. Should your doors arrive and not be properly aligned, follow these steps to adjust them.

1.1. To adjust the door's depth, loosen screw (a), adjust the door, and then tighten screw (a).

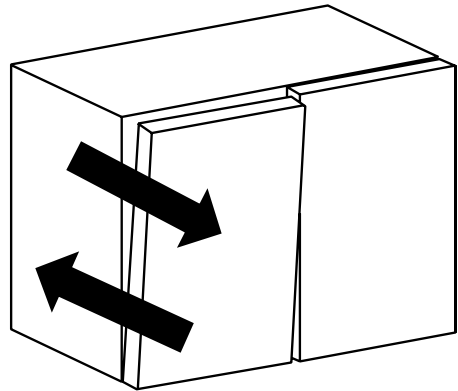
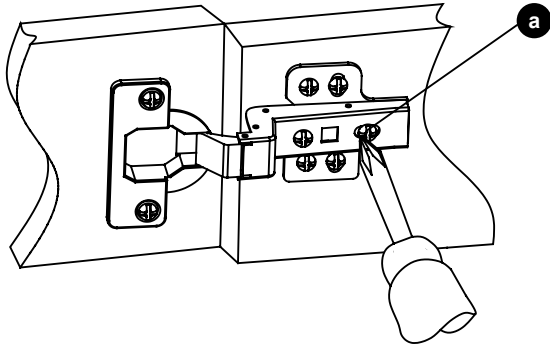

# 2 Door's left and right adjustment

2.1. To adjust the door horizontally, rotate the adjustment screw (b).

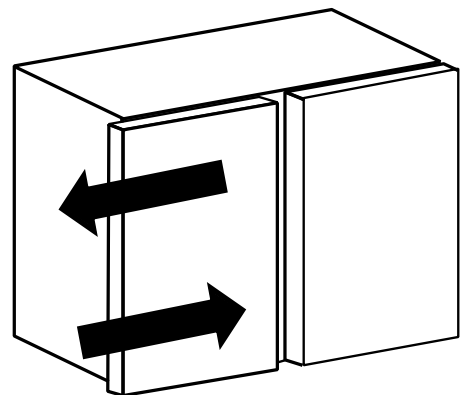
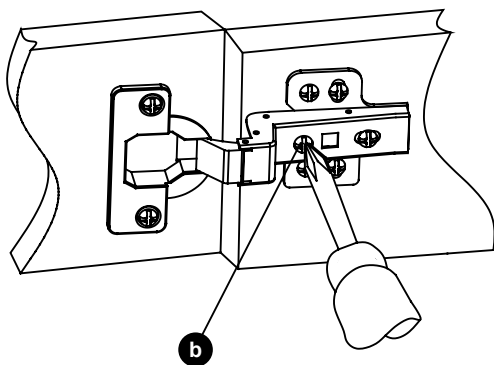

## MAINTENANCE AND CARE

### Cabinet Care

- For daily maintenance, use a wet cloth and a soft liquid cleaner.
- Never use abrasive cleaners or strong bleach, scrapers, metallic brushes, or other objects or any products which can graze or tarnish surfaces.

### Disclaimer: Natural Variations In Color And Pattern

- Due to the natural characteristics of wood and stone, the veneer, finish, and countertop of this product may exhibit variations in color, grain pattern, and texture. These natural differences are inherent to the material and are not considered defects. Each piece is unique, and the appearance may vary slightly from the product images or from piece to piece. By purchasing this product, you acknowledge and accept these natural variations as part of the beauty and uniqueness of the product.

### Vanity Top Care

- Stone countertops (Granite, Marble, etc.) are surprisingly resilient to stains and scratches. However, as a preventative measure, any spills on the stone surfaces should be wiped up within a reasonable amount of time. Don't let the liquid sit on the stone overnight. Stones are most prone to staining by oil and acid, so be sure to blot these spills up as soon as they happen. Follow up by cleaning the stone with mild non-abrasive soap and water.
- In bathrooms specifically, stone tends to attract soap scum, just like man-made tile. Rinse the vanity top with clean, hot water frequently.
- The use of sealers is also a powerful preventative measure. Your stone was sealed at the factory, but reapplication is necessary over time. How often is determined by the quality of the sealer used, and the frequency of use. We recommend using a penetrating non-toxic sealer for bath areas, but a food-safe sealer is typically not necessary.
- If stains and scratches do occur, there are many things you can do as a consumer to remove them. Remove oil-based stains with acetone, mineral spirits, or ammonia. Organic stains like coffee, tea, or juice can be removed with hydrogen peroxide, and mixed with a few drops of ammonia.

Water spots or rings are the most common problem with bath vanities and are caused by minerals left behind when water evaporates. These can be removed by buffing the spots gently with 00-gauge steel wool. Likewise, small nicks and scratches can often be removed in the same way. Larger scratches, chips, and resilient stains may require professional help. Please contact your local stonemason for details.

Remember the following list of **DOs** and **DON'Ts**:

- **DO** use preventative cleaning measures to keep your stone pristine.
- **DO** use sealers, applied according to the product-specific directions.
- **DO** blot spills quickly, and wash with mild soap and warm water.
- **DON'T** use harsh bathroom cleaners or grout cleaners on any natural stone.
- **DON'T** worry if you get a significant stain or scratch that your stone investment is ruined. Virtually anything can be fixed with professional help.

### CUSTOMER SERVICE:

For warranty issues, missing or damaged parts, or for additional product information, please contact our Customer Service Center at 1-866-839-2888 between 8 am and 5 pm Eastern Time, Monday through Friday.

### LIMITED 1 YEAR WARRANTY

This warranty applies to OVE DECORS vanities installed for commercial and residential use.

OVE DECORS warrants that, when installed in accordance with the Recognized Plumbing Industry Practice, the vanities are free of manufacturing defects for a period of one (1) year from the date of purchase.

We guarantee your satisfaction with each vanity. Should any vanity not meet your satisfaction due to a visual defect, simply return it to your retailer with the original packaging, PRIOR TO INSTALLATION, for a replacement.

This warranty applies only to the original purchaser and installation site and is not transferable.

### INFORMATION ABOUT YOUR WARRANTY COVERAGE

This warranty does not cover damages or failure attributable to:

- ▶ Vanities installed with obvious visual defects.
- ▶ Defects or damages to vanities caused by installation that do not comply strictly with the instructions set forth in OVE DECORS's installation manual.
- ▶ Defects or damage to vanities caused by severe accidents (e.g., fire, impacts).
- ▶ Damage caused by flooding or standing water from leaking pipes, faucets, household appliances, etc; up to and including flooding and any damage caused by acts of God.

### FOR WARRANTY SERVICE

- To make a claim, contact OVE DECORS no later than 30 days following the date of discovery or detection of the defect.
- Proof of purchase, such as the bill of sale is mandatory when requesting warranty service.
- OVE DECORS reserves the right to designate a representative to inspect the vanity for analysis.
- No unauthorized person, installer, dealer, agent or employee of OVE DECORS or any representative is entitled to assume any liability on behalf of OVE DECORS relating to the sale of this product or has the authority to increase or alter the obligations or limitations of this warranty.

**THE SOLE REMEDY PROVIDED BY THIS WARRANTY IS THE REPAIR OR REPLACEMENT OF DEFECTIVE PRODUCTS.  
THIS WARRANTY DOES NOT COVER THE COST OF REMOVAL OR INSTALLATION OF NEW PRODUCTS.  
THE WARRANTY WILL BE VOID IF THIS ITEM IS INSTALLED WITH OBVIOUS VISUAL DEFECTS.**



### Questions, problems, need help?

Before returning to your retailer, contact our customer service department with the QR code :

8 a.m. - 5 p.m., EST, Monday - Friday



1-866-839-2888