

**100 160 180 200 210 270 280
340-2 350 390 420
Gasoline Engine
Owner's Manual**

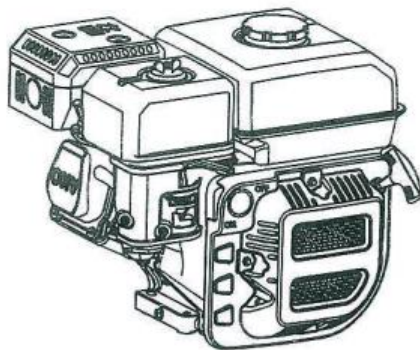

PREFACE

Thank you for choosing our general-purpose gasoline engine.

The manual gives information with respect to operation and maintenance of the 100 160 180-3 200 210 270 280 340-2 350 390 420-2 420-2A and 200-4 210-2 270-3 390-3 420, general-purpose gasoline engines, and be sure to read it carefully first before operation. Only operate as the manual tells, can insure user's safety and get the best results of the engine operation.

All information and diagrams of this manual are in accordance with the newest products at the publishing time. If revision and other change the information described in this manual are a little different from the actual status, our company will explain it. Our company reserves the right to make change at any time without notice and without incurring any obligation. No part of this publication may be reproduced without written permission.

This manual should be considered a permanent part of the engine and should remain with the engine if it is resold!

SAFETY MESSAGES

Your safety and the safety of others are very important. We have provided important safety messages in this manual and on the gasoline engine. Please read these messages carefully.

A safety message alerts you to potential hazards that could hurt you or others. Each safety message is preceded by a safety alert symbol. Symbol is as following:

 **WARNING** You CAN be **KILLED** or **SERIOUSLY HURT** if you don't follow instructions.

 **CAUTION** You CAN be **HURT** if you don't follow instructions.

 **NOTICE** Your generator or other property could be damaged if you don't follow instructions.

 **NOTE** Give you helpful information.

CONTENTS

PREFACE	1
SAFETY MESSAGES	2
CONTENTS	3
I. SAFETY PRECAUTIONS	4
II. PARTS DESCRIPTION	6
III. BATTERY CONNECTION	7
IV. PRE-OPERATE INSPECTION	9
V. STARTING THE ENGINE	13
VI. RUNNING THE ENGINE	16
VII. STOPPING THE ENGINE	18
VIII. EXHAUST CONTROL SYSTEM.....	19
IX. MAINTENANCE.....	20
X. TRANSPORT AND STORAGE.....	24
XI. TROUBLESHOOTING	25
XII. SPECIFICATIONS	30
XIII. ELECTRIC DIAGRAM	33

I. SAFETY PRECAUTIONS



Indicate a possibility of invalid warranty and personal or equipment damage if instructions are not followed.

Please pay special attention to the following:

1. Strictly set the engine according to the regulated power on the owner's manual. Do not overload, overrun the engine or run it with low load and at low speed in a long time.
2. Use regulated brand of gas and diesel. The fuel should be fully deposited and filtrated before use. Keep clean the fuel filler, change the oil periodically.
3. Periodically check the installation, connection and the degree of tightness of the fixed bolt. Tighten it if necessary.
4. Periodically clean the element of the air cleaner, change it when necessary.
5. The gasoline engine is air-cooled, so clean the radiator, wind cover and fan in time in order to make the engine cool normally.
6. The operator should be familiar with the working principle and structure of the gasoline engine, knowing how to make an emergent stop and the operation of all controlling parts. Any one without training is forbidden to operate the engine. Keep periodical maintenance. Solve problems in time. Do not run the engine in spite of malfunction.
7. Running the engine in a well-ventilated place, keep it at least one meter away from building walls or other equipments, keep away from

SAFETY PRECAUTIONS

inflammables such as gasoline, matches and so on to avoid possibility of fire.

8. Refuel in a well-ventilated area with the engine stopped, do not smoke and do not allow flames or sparks in the refueling area.
9. Do not overfill the fuel tank to avoid fuel's spilling out. If there is spilled fuel around, be sure to clean it thoroughly before starting.
10. Do not run the engine inside the buildings or enclosure areas.
11. The exhaust muffler is very hot during running the engine even after the engine stops. Never touch it, or you may get burns. Transport or store the engine with it cooling down entirely.
12. Safe warning label:

Please carefully read warning label before operating. Our company will not accept any responsibility for person hurt, or equipment damaged caused by disregarding this warning label.

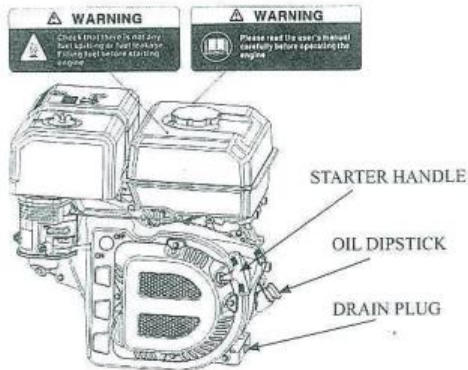

II. PARTS DESCRIPTION

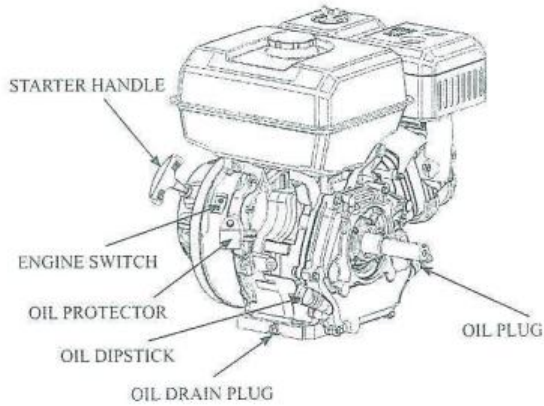
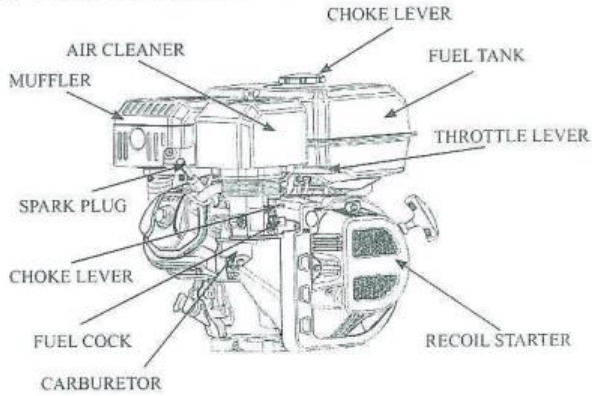

III. BATTERY CONNECTION

Use 12V and more than 18AH battery, connect its positive lead to start relay terminal while connect its negative lead to engine mounting screw, base screw or other grounding point with the engine.(See the following picture)

Check the battery's connecting point; make sure that it is tight and not rusted. If rusted, clean and connect.

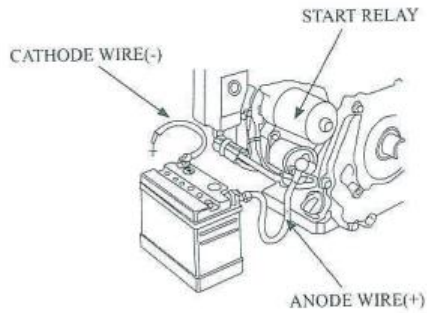

⚠ WARNING

- 1) The battery may give off explosive gas, keep sparks, flames and cigarettes away. Charge or use it indoors with good ventilation.
- 2) The battery contains sulphuric acid (electrolyte). If contact with skin or eyes may cause severe burns. If electrolyte gets in your skin, flush with water; if gets in your eyes, flush with water for at least 15 minutes and call a physician at once.
- 3) Electrolyte is poisonous. If swallowed, drink large quantities of

BATTERY CONNECTION

water or milk, and follow with milk of magnesia or vegetable oil and call a physician.

- 4) Keep out of reach of children.

NOTICE

- 1) Do not add tap water to the battery instead of distilled water, otherwise the battery service life will be shortened.
- 2) Do not add distilled water over the electrolyte upper level mark, if not, electrolyte will spill out and corrupt the engine part. If so, be sure to wash them away with water.
- 3) Make sure not to connect the battery leads in reverse order, otherwise short-circuit or breaker's trip may be result in.

IV. PRE-OPERATE INSPECTION

1. ENGINE OIL



Use 4-stroke engine oil, API service classification SE class or equivalent. Check the API service label on the oil container to be sure it includes the letters SE class or equivalent.

SAE 10W-30 is recommended for general use. Other viscosities shown in the chart may be used when the average temperature in your area is within the indicated range.

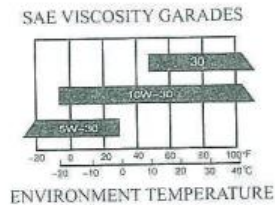

Oil level check

Check method:

- 1) Remove the dipstick and clean it.
- 2) Reinsert the dipstick into the oil filling hole without screwing it, and check oil level.
- 3) If the oil level is too low, add the recommended engine oil up to the oil filling neck.
- 4) Reinstall the dipstick.
- 5) Lubrication oil capacity:

	100	0.35L
160 180-3 200 200-4 210 210-2		0.6L
270 270-3 280 340-2 370 390 390-3 420 420-2 420-2A		1.1L

PRE-OPERATE INSPECTION

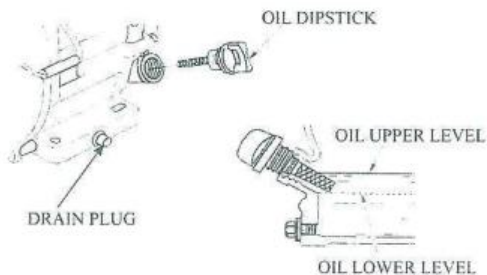

NOTICE

Run with insufficient engine oil may damage the gasoline engine severely and that is not within valid warranty.

2. AIR CLEANER

Dismantle the air cleaner cover and check its element to make sure it clean and complete. Clean or replace it as necessary(see page 22: maintenance of air cleaner).

NOTICE

Never run the engine without an air cleaner, or severe wear of the engine may be resulted in. That is not within the valid warranty.

3. FUEL RECOMMENDATION

- 1) Remove the fuel tank cap and check fuel level.
- 2) If the level is too low, refuel the tank. Remember adding fuel not

over the fuel filler shoulder.

WARNING

- 1) Gasoline is extremely flammable and is explosive under certain conditions.
- 2) Refueling in a well-ventilation area with the engine stopped. Do not smoke and do not allow flames or sparks in the area where gasoline is stored or where the fuel tank is refueled.
- 3) Do not overfill the fuel tank (there should be no fuel in the filling neck). After refueling, make sure the fuel tank cap is set back securely.
- 4) Be careful not to spill fuel when refueling. Spilled fuel or fuel vapor may ignite. If any fuel is spilled, make sure the area is dry before starting the engine.
- 5) Avoid repeated or prolonged contact with skin or breathing of fuel vapor. Keep out of reach of children.

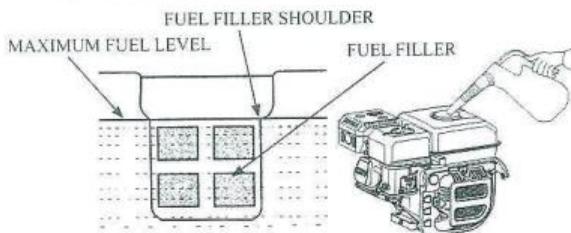

Fuel tank capacity:	100	2L
	160 180-3 200 200-4 210 210-2	3.6L
	270 270-3 280 340-2 350 390 390-3 420 420-2 420-2A	6.5L

PRE-OPERATE INSPECTION

NOTICE

Fuel may damage the oil paint and plastic. Be careful not to spill fuel when refueling. Any damage due to oil spilling is not within valid warranty.

"Light knocking" or "spark exploding" sound can be hear when the engine overloading. It is normal. Do not be worry about that.

If " knocking" or "spark exploding" sound occur at a steady speed under normal load, change brand of gasoline; if such phenomena still happen, consult your dealer for help, otherwise the engine may be damaged.

NOTICE

When the engine is running, continuously "Knocking" or "spark exploding" sound occurring will damage engine.

"Knocking" or "spark exploding" sound from misusing will not be within the valid warranty.

V. STARTING THE ENGINE

1. Turn the fuel cock to the "ON" (OPEN) position.

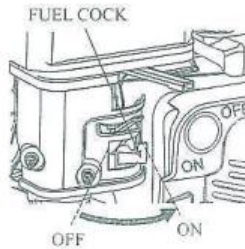

2. Turn the choke lever to the "CLOSE" (OFF) position.
If the gasoline engine is hot, don't close the choke.

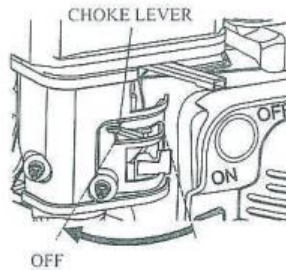

STARTING THE ENGINE

3. Move governor lever to left a little.

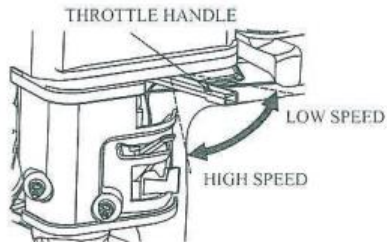

4. Start the engine

- 1) Recoil starter:

Turn the engine switch to the "ON" (OPEN) position.

Pull the starter grip lightly until resistance is felt, then briskly.

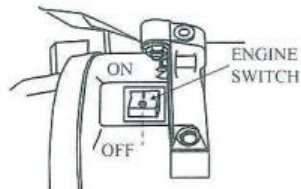

NOTICE

Don't allow the starter grip to snap back against the engine.

Return it gently to prevent damage to the starter



2) Electric start

Turn the engine switch to the "START" position, and hold it there until the gasoline engine starts. When the engine starts, allow the engine switch to return to the "ON" position.

ENGINE SWITCH



NOTICE

Do not use the starter for more than 5 seconds or starter motor damage may occur. If the engine fails to start, release the switch and wait 10 seconds before operating the starter again.

VI. RUNNING THE ENGINE

1. Preheat the engine and push back the choke lever to the "OPEN" position.



2. Move the throttle lever to proper position to make the gasoline engine run at required velocity.



ENGINE OIL ALARM

The engine oil alarm is designed to function when the engine oil in the crankcase is insufficient. Lack of engine oil may damage the engine. Once oil level in the crankcase is too low, the engine oil alarm will stall the engine automatically to make it free of damage while the engine switch is still at "ON".

NOTICE

If cannot restart the engine, check the engine oil level first before go to other check items.

BREAKER (Electric-start type)

The breaker will cut off automatically to protect the charging circuit of the battery in the case that short circuit or incorrect connection of the battery poles occurs.

The green indicator in the breaker will jump out with the circuit cutting off. After finding troubles and troubleshooting, depress the breaker button to turn the breaker on.

HIGH ALTITUDE OPERATION

At high altitude, the standard air-fuel mixture will be too rich. Performance will decrease and fuel consumption will increase. A very rich mixture will also foul the spark plug and cause hard starting. High altitude performance can be improved by specific modifications to the carburetor. If you always operate you trimmer at altitudes above 1000 meters, have your servicing dealer perform this.

NOTICE

Modified engine applicable to altitude may be damaged seriously in area below altitude of 1000 meters for overheating, because its mixture ratio is too small for operation in low altitude area. When the carburetor has been modified for high altitude, operation the air - fuel mixture will be to lean for low altitude use. Operation at altitudes below 1000 meters with a modified carburetor may cause the engine to overheat and result in serious engine damage.

VII. STOPPING THE ENGINE

In emergency, push the engine switch to the "OFF".

In normal, please do as following:

1. Push right the throttle lever to low speed position.



2. Push the engine switch to the "OFF" position.

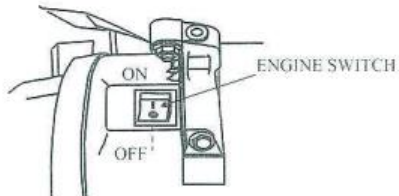

3. Set the fuel cock to "OFF" position.

NOTICE

Sudden stopping at high speed under heavy load is forbidden, otherwise damage will result.

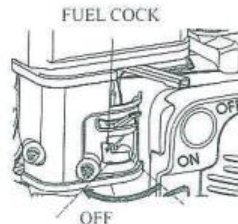

VIII. EXHAUST CONTROL SYSTEM

With the engine running, carbon monoxide, oxide of nitrogen and hydrocarbon will produce, and in certain conditions, oxide of nitrogen and hydrocarbon will react chemically each other to make smoke while carbon monoxide is toxic, so exhaust control of them is very important.

To keep the exhaust of your engine with in the standard exhaust emission, pay attention to the following:

1. Maintenance

Maintain the engine periodically in accordance with the maintenance schedule in the manual. The maintenance schedule is made out on the base of normal use in normal conditions, if using under heavy load, dusty or wet circumstances or in high temperature, service of the engine should be done more often.

2. Problems affecting exhaust emissions

- 1) Difficult starting or difficult stopping.
- 2) Unstable idling speed.
- 3) Give off black smoke or consume fuel too much
- 4) Poor ignition sparks or fire back.
- 5) Too early ignition.

Once you find any of above problems, contact your dealer for help.

MAINTENANCE

IX. MAINTENANCE

1. MAINTENANCE SCHEDULE

In order to keep the gasoline engine well, must periodically service and adjust the engine. Service shall be as following schedule.

MAINTENANCE SCHEDULE

Items	Frequency	Frequency				
		Each time	First month or 20 hrs	Each season or 50 hrs	Every 6 month or 100 hrs	Each year or 300 hrs
Engine Oil	Oil level check	√				
	Replace		√		√	
Reduction Gear Oil	Oil level check	√				
	Replace		√		√	
Air Cleaner	Check	√				
	Clean			√	√	
	Replace					√
Deposit Cup	Clean				√	
Spark Plug	Clean, adjust				√	
	Replace					√
Spark Arrester	Clean				√	
Idling	Check-adjust					√*
Valve Clearance	Check-adjust					√*
Fuel Tank & Fuel Filter	Clean					√
Fuel Supply Line	Check	Every two years (do a replacement if necessary)				
Cylinder head and the head of piston	Clean carbon	Every 125 hours*				

* These items should be serviced by our authorized our company servicing dealer, unless you have the proper tools and are mechanically proficient.

⚠ WARNING

Stop the engine before servicing. If service is required with the engine running, be sure to keep good ventilation in the area. The exhaust emissions from the engine contain toxic carbon monoxide, inbreathing of it may result injury and even death.

2. MAINTENANCE METHOD

- 1) Replacement of engine oil (see page 9 to check method)
Drain the engine oil rapidly and completely out when the engine is hot.
 - (1) Turn off the oil filler cap and drain plug to drain engine oil thoroughly.
Reinstall the drain plug and screw in securely.
 - (2) Fill the specified engine oil up to the upper level mark.
 - (3) Reinstall the oil filler cap.

NOTICE

Do not dump oil containers or discarded engine oil into rubbish boxes or onto the ground. For the sake of environmental protection, we suggest you take in discarded engine oil with a closed container and bring to local recycling station.

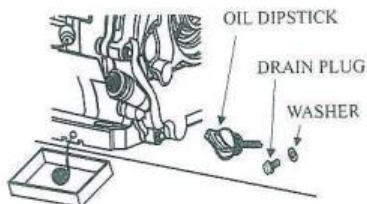

MAINTENANCE

2) Maintenance of air cleaner

A dirty air cleaner can restrict air flowing into the carburetor. To keep the carburetor in good working conditions, please service the air cleaner periodically. If operating the engine in extremely dusty area, the job should be done more often.



Never clean the air cleaner element with gasoline or low flash-point detergents, or explosion may happen.



Never run the engine without an air cleaner, because air with dirt and dust entering the engine can speed up the engine wear.

- (1) Remove the air cleaner cover off and take the element out.
- (2) Paper element: Wash the element with home detergents and warm water (or non-flammable or high flash-point cleansing solvents) and dry up.
Foam element: Soak in clean engine oil until saturated. Squeeze out excess oil, otherwise, the engine will smoke in starting stage.
- (3) Clean the air cleaner cover and inner surface with wet cloth, be careful not to allow the dust entering into the carburetor.
- (4) Reinstall the element and put the air cleaner cover on.

3) Spark plug

Spark plug type: BPR6ES (NGK) or NHSP LD F7RTC

In order to ensure the engine normal running, gap of the spark plug must be correct and no deposit around the spark plug.

- (1) Remove the spark plug cap.

- (2) Clear away dirt around the spark plug base.
- (3) Dismantle the spark plug with a spark plug wrench.
- (4) Visually check the spark plug. Clean with a steel brush. If the insulator is damaged, replace the spark plug instead.
- (5) Measure the spark plug clearance with a feeler. The clearance should be 0.7–0.8mm. If adjustment is necessary, bend the side electrode carefully.
- (6) Check if the spark plug gasket is in good conditions. In order to screw thread misplace, screw in by hand.
- (7) Screw on the spark plug to the bottom first by hand and then screw in by a spark plug wrench and compress the gasket.
 - If a new spark plug is used, more twist 1/2 turns after compressing the gasket.
 - If reinstalling the used spark plug, just more twist 1/8-1/4 turns.

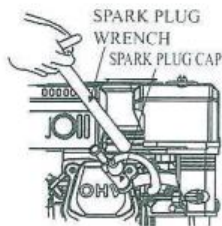

WARNING

Don't touch the muffler in running and just gasoline engine stopping stage to avoid burn.

NOTICE

The spark plug must be tightened securely, or it may become very hot to damage the engine.

X. RANSPORT AND STORAGE

Transport with the fuel cock turned the "OFF" position. Transport or store the engine when it is cool so as to avoid getting burns or fire.

NOTICE

Do not incline the engine so as to avoid fuel's spill. Spilled fuel or fuel vapor may ignite to cause fire.

If the engine is not kept in use for a long time, be sure to store it properly.

1. Make sure the storage area is dry and free of dust.
2. Turn the fuel cock to "OFF" position, set a proper container under the carburetor (as shown on the fig).
3. Open the fuel cock to completely drain gasoline out of the fuel tank.
4. Reinstall the oil drain plug back and tighten it.

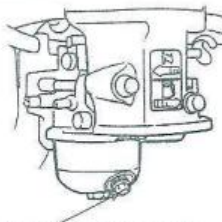

CARBURETOR OIL DRAIN PLUG

WARNING

Fuel is extremely flammable and explosive under certain conditions. Keep smoke, fire and spark away from operating site.

5. Drain the oil out of the gasoline engine.
6. Remove the spark plug. Fill about a spoon of fresh engine oil onto the cylinder. Crank the engine up to distribute engine oil evenly. Reinstall the spark plug.
7. Electric starter: Remove the battery and store in dry and cool area. Charge one every month.
8. Cover the engine to protect dust entering.

RANSPORT AND STORAGE

Please maintain according to following table when reuse after storing.

Storing time	Maintaining procedure is commended in order to prevent starting difficult.
1 month	Don't need to prepare.
1-2 month	Drain the used gasoline out and add the fresh gasoline
2 months to 1 year	Drain the used gasoline out and add the fresh gasoline. Drain the gasoline ① out of the carburetor cup. Drain the gasoline ② out of the sediment bowl.
1 year over	Drain the used gasoline out and add the fresh gasoline . Drain the gasoline ① out of the carburetor cup. Drain the gasoline ② out of the sediment bowl. After removing out of the storage, first, drain the used gasoline to proper container, and don't start before adding fresh gasoline.
Loosen the oil drain bolt and completely drain the gasoline out of the carburetor to proper container and screw the oil drain bolt down. Remove the sediment bowl after closing fuel cock, and completely pour the gasoline out the sediment bowl. Finally reinstall the sediment bowl back and screw it down.	

TROUBLESHOOTING

XI. TROUBLESHOOTING

I. START ENGINE DIFFICULTLY (By using recoil starter):

TROUBLE		CAUSE	REMEDY	
Normal cylinder compression	Normal spark plug spark	Something wrong with the fuel system. Fuel supply is not smooth or no fuel supply.	There is not enough fuel in fuel tank and fuel cock is closed.	Fill fuel, open fuel cock.
			Air vent in the fuel filler cap is clogged	Dredge air vent.
			Fuel cock is clogged	Clean first and then dredge
			Improper or clogged main oil flow hole.	Readjust or clean, blow to get through.
			Needle valve is not closed properly or start hole is clogged.	Dismantle needle valve and repair, clean, blow to get through.
			Float is damaged or sticking.	Repair float
	Normal fuel supply system.	Fuel supply is normal.	Fuel is too filthy or deteriorated	Replace
			There is water in fuel.	Replace
			Too much fuel in engine	Drain extra fuel, dry up spark plug electrodes.
			Wrong fuel brand	Select proper fuel brand corresponding with the requirements.
	High-tension line no spark	Normal high-tension line spark	Too much carbon deposit and dirt around electrodes.	Clear away.
			Electrodes are burn damaged seriously or insulators damaged.	Replace spark plug.
			Improper electrodes gap.	Adjust to proper value.
	High-tension line no spark	Normal spark plug	High-tension line is damaged.	Replace
			Ignition coil is damaged.	Replace
Magneto loses magnetism.			Replace	
Abnormal gap between ignition coil and flywheel.			Adjust gap	

TROUBLESHOOTING

TROUBLE	CAUSE	REMEDY	
Abnormal cylinder compression. Normal fuel supply system. Normal spark plug.	Piston ring is worn to or even over its wear limit	Replace	
	Piston ring is broken.	Replace	
	Piston ring is sticking.	Clear up carbon fouling.	
	Spark plug is not installed tighten or without a gasket.	Tighten with a gasket in.	
	Air leakage between cylinder block and cylinder head.	Check cylinder gasket, and the flatness of the surface by which cylinder block contacting with cylinder head	
		Tighten cylinder head bolts in stipulated order to stipulated torque.	
Air leakage in the valves	Check valve. Clearance and tightness, repair if necessary.		

If still can't starting, have the gasoline engine to our authorized dealer for repairing.

 **WARNING**

- When testing the spark plug, never hold the high-voltage wire of the spark plug with wet hand.
- Make sure there is no spilled fuel outside the engine and that the spark plug isn't dipped with fuel.
- To prevent fire, keep sparks far away from the spark plug mounting hole.

START ENGINE DIFFICULTLY (By using starting motor):

ITMES	CAUSE	REMEDY
Check battery connection	Incorrect connection	Correct
Check battery	No charge or under charge, corrosion	Check the breaker, charge up the battery or replace it.

TROUBLESHOOTING

2. GASOLING ENGINE POWER OUTPUT INSUFFICIENCY:

TROUBLE	CAUSE	REMEDY	
When increasing throttle, speed increase slow or even decrease and stop running	Fuel supply system	Air in fuel line or fuel line clogged	Exhaust air or dredge fuel line
		Main oil flow hole is not adjusted properly	Readjust
		In carburetor, needle valve hole and main oil flow hole clogged.	Clean and blow to get through
		Fuel cock is clogged up.	Clean, replace damaged part
		Too much carbon deposit in combusting chamber.	Clear away
		Too much carbon fouling in muffler and exhaust pipe.	Clear away
		Air cleaner is clogged up.	Clean air cleaner filter element
		Intake pipe is leaking	Repair or replace
	Poor compression	Piston or cylinder or piston ring is worn	Replace the worn
		Air leakage from the surface by which cylinder block contacting with cylinder head.	Replace cylinder gasket
		Too big or too small valve clearance.	Readjust
		Valve tightness is poor.	Repair

3. GASOLINE ENGINE RUNNING UNSMOOTHLY:

TROUBLE	CAUSE	REMEDY
Knocking sound	Piston, cylinder or piston ring is worn excessively.	Replace the worn
	Piston pin and piston pin hole are worn excessively.	Replace piston or piston pin
	Tie rod small head is worn excessively.	Replace tie rod
	Roller bearing for crankshaft main shaft is worn.	Replace roller bearing
Abnormal combustion	Engine is too hot	Shoot trouble
	Too much carbon deposit in combustion chamber	Clear away
	Improper gasoline brand or low gasoline quality	Replace with qualified gasoline
Spark lacking	There is water in float chamber	Clean
	improper spark plug electrodes clearance	Adjust
	Something wrong with induced coil, and so on	Check and replace damaged parts

4. STOP SUDDENLY WHEN RUNNING:

TROUBLE	CAUSE		REMEDY
Stop suddenly when running.	Fuel supply system	Fuel is finished	Refill fuel
		Carburetor is clogged	Check fuel line and dredge
		Float is leaking	Repair
		Needle valve is stuck	Dismantle float chamber and eliminate it
	Ignition system	Spark plug is punctured, or short-circuited by carbon deposit	Replace spark plug
		Side electrode of spark plug is dropped out	Replace spark plug
		High-tension wire is dropped out	Weld on
		Ignition coil is punctured or short-circuited	Replace ignition coil
		Parking wire is located on engine body	Find out meeting and insulate
	The other	Cylinder is seriously scored and valve dropped out	Repair or replace damaged parts

5. GASOLINE ENGINE IS OVERHEAT

TROUBLE	CAUSE	REMEDY
Gasoline Engine is Overheat.	Oil insufficient	Refill engine oil enough
	Exhaust pipe blocked up	Clean exhaust pipe
	Shroud leaking	Repair damaged part
	Cooling fins blocked by foreign matter	Clear cooling fins
	Cooling fan loosen and malfunction	Reinstall well
	Connection rod deformation to make piston and cylinder bushing side wear	Replace connection rod
	Cylinder or piston or piston ring is worn to make hunting between cylinder and crankcase	Replace the worn parts
	Improper adjustment of engine governor to produce speed high.	Readjust engine governor
	Crankshaft main bearing burnt out	Replace main bearing

TROUBLESHOOTING

6. THERE EXISTS ABNORMAL NOISE WHEN ENGINE RUNNING

TROUBLE	CAUSE	REMEDY
Beating sound	Piston, piston ring or cylinder is worn	Replace the worn part
	Connection rod or piston pin and piston pin hole are worn	Replace the worn part
	Crankshaft main neck is worn	Replace bearing
	Piston ring is broken	Replace piston ring
Metal beating sound when abnormal combustion occurs	Too much carbon deposit in combusting chamber	Clear away carbon deposit
	Too small electrode clearance of spark plug	Adjust electrode clearance properly
	Engine fuel is too much	Check relative parts such as carburetor
	Improper fuel brand	Replace fuel
	Engine is overheat	Find a cause and eliminate it
The other	Improper valve clearance	Readjust valve clearance properly
	Fly wheel is not connected with crankshaft tightly	Connect tightly

XII. SPECIFICATIONS

1. 160 200 200-4 210 210-2

1) MAIN SPECIFICATION

Specification \ Model	100	160	180-3	200/200-4	210/210-2
L×W×H	310×290×300mm		390×320×345mm		
Dry Weight	10kg	15.5kg	16 kg	16 kg	16 kg
Gasoline Engine Type	4-Stroke, OHV, Single Cylinder				
Displacement	98ml	163ml	179ml	196ml	212ml
Compression Ratio	8.5:1				
Bore × Stroke	56×40mm	68×45mm	65×54mm	68×54mm	70×55mm
Maximum Output Power	1.8kW/3,600r/min	3.4kW/3,600r/min	3.5kW/3,600r/min	4.0kW/3,600r/min	4.2kW/3,600r/min
Maximum Torque	4.7N·m/2,500r/min	9.0N·m/2,500r/min	9.5N·m/2,500r/min	11N·m/2,500r/min	12N·m/2,500r/min
Cooling System	Forced Air-cooled				
Ignition System	Transistorized Magneto Ignition (TCI)				
Spark Plug	E7TC	BP6ES (NGK) / F6RTC (NHSP)	P6TC	BP6ES (NGK) / F6RTC (NHSP)	
Lubrication System	Forced Splash				
PTO Shaft Rotation	Counterclockwise				

DATA ADJUSTMENT:

Items	Technical Data
Spark Plug Clearance	0.7- 0.8mm
Valve Clearance (Cold Engine)	Intake: 0.10-0.15mm Exhaust: 0.15-0.20mm

SPECIFICATIONS

2) TORQUE OF IMPORTANT BOLTS

Items	100			160/180-3/200/200-4/210/210-2		
	Specifications	Torque Valve		Specifications	Torque Valve	
		N·m	Kg·m		N·m	Kg·m
Connection-Rod Bolt	M6×25	12	1.2	M6×1.25(special)	13	1.3
Cylinder Head Bolt	M8×55	32	3.2	M10×1.25	35	3.5
Flywheel Nut	M12×1.5	55	5.5	M14×1.5(special)	85	8.5
Lock Nut Of Rocker Arm Shaft	M6×0.5	10	1.0	M6×0.75	10	1.0
Rocker Arm Stud	M6×1	24	2.4	M8×1.25(special)	24	2.4
Crankcase Bolt	M6×25	11	1.1	M8×1.25	28	2.8

2. 270 270-3 280 340-2 350 390 390-3 420 420-2 420-2A

1) MAIN SPECIFICATION

Specification	Model	270/270-3	280	340-2
L×W×H		415×392×425mm		465×413×440mm
Dry Weight		26kg		32kg
Engine Type		4-Stroke, OHV, Single Cylinder		
Displacement		270ml	277ml	338ml
Compression Ratio		8.2:1	8.2:1	8.0:1
Bore × Stroke		77×58mm	78×58mm	82×64mm
Maximum Output Power		5.6kW/3,600r/min	5.8kW/3,600r/min	6.8kW/3,600r/min
Maximum Torque		16.8N·m /2,500r/min	17N·m /2,500r/min	20N·m / 2,500r/min
Cooling System		Forced Air-Cooled		
Ignition System		Transistorized Magneto Ignition(TCI)		
Spark Plug		BP6ES (NGK) / F6RTC (NHSP)		
Lubrication System		Forced Splash		
PTO Shaft Rotation		Counterclockwise		

SPECIFICATIONS

Model	350	390/390-3	420/420-2/420-2A
Specification			
L×W×H	465×413×440mm	465×413×440mm	465×413×440mm
Dry Weight	32kg	32kg	32.5kg
Engine Type	4-Stroke, OHV, Single Cylinder		
Displacement	346ml	389ml	420ml
Compression Ratio	8.0:1	8.0:1	8.0:1
Bore × Stroke	83×64mm	88×64mm	90×66 mm
Maximum Output Power	7kW/3,600r/min	7.6kW/3,600r/min	8.5kW/3600 r/min
Maximum Torque	21N·m / 2,500r/min	23N·m /2,500r/min	25N·m /2,500r/min
Cooling System	Forced Air-Cooled		
Ignition System	Transistorized Magneto Ignition(TCI)		
Spark Plug	BP6ES (NGK) / F6RTC (NHSP)		
Lubrication System	Forced Splash		
PTO Shaft Rotation	Counterclockwise		

DATA ADJUSTMENT:

Items	Technical data
Spark Plug Clearance	0.7-0.8mm
Valve Clearance (Cold Engine)	Intake: 0.10-0.15mm Exhaust: 0.15-0.20mm

2) TORQUE OF IMPORTANT BOLTS:

Items	Specifications	Torque Valve	
		N·m	Kg·m
Connection-Rod Bolt	M8×1.25(special)	15	1.5
Cylinder Head Bolt	M10×1.25	45	4.5
Flywheel Nut	M16×1.5(special)	95	9.5
Lock Nut Of Rocker Arm Shaft	M6×0.75	10	1.0
Rocker Arm Stud	M8×1.25(special)	24	2.4
Crankcase Bolt	M8×1.25	28	2.8

XIII. ELECTRIC DIAGRAM

1. Electric Starter Engine With Oil Protection System

Combination Switch

	IG	E	ST	BAT
OFF	O	O		
ON				
START			O	O

B	BLACK	B	BROWN
Y	YELLOW	R	RED
W	WHITE	G	GREEN

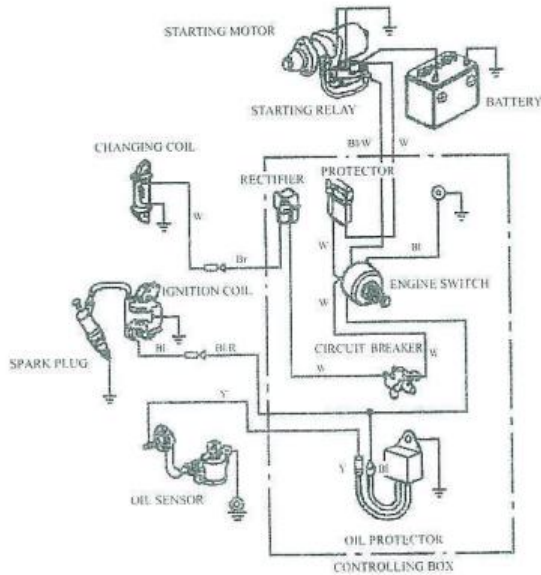

With Oil Protection System

2.No Electric Starter Engine With Oil Protection System

BI	BLACK
Y	YELLOW
G	GREEN

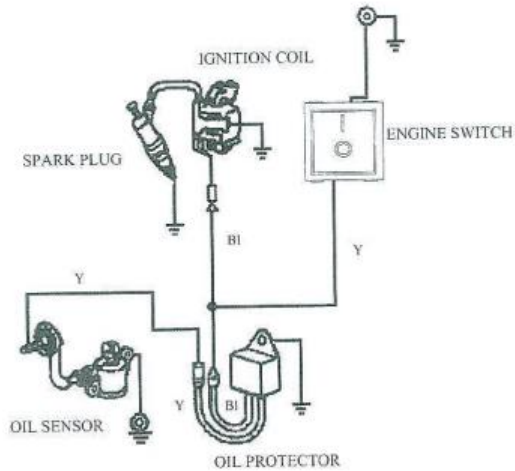

XIV. EASY WORN PARTS AND ACCESSORIES LIST

EASY WORN PARTS LIST:

CRANKCASE GASKET
CYLINDER HEAD COVER GASKET
CYLINDER HEAD GASKET
CARBURETOR GASKET
CARBURETOR INSULATION GASKET
AIR CLEANER GASKET
EXHAUST VENT GASKET
SPARK PLUG
RECOIL STARTER
SEAL GUIDE
OIL SEALING

ACCESSORIES PART:

SOCKET
FORCE BAR

93004-Z010230-0000