

COMMERCIAL & INDUSTRIAL SECTIONAL DOORS

INSTALLATION & MAINTENANCE

COMMERCIAL HOTLINE • 1-800-621-3667

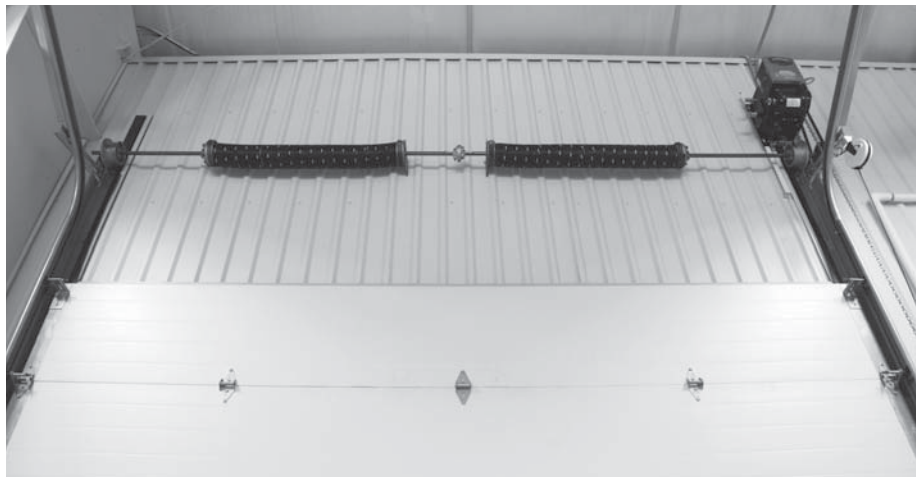

Model: _____ Serial No. _____

(Provided on label on interior door surface)

Size: _____

Dear IDEAL Door Customer,

Thank you for purchasing an IDEAL Door Garage Door. Your new IDEAL Door Garage Door was built to meet the highest industry standard and to provide you with years of dependable performance. This manual contains important safety, installation and maintenance instructions. Carefully follow the instructions and maintenance recommendations. Please keep this manual for future reference. If you should require any assistance or additional information, please call the hotline number on the cover of this manual.

Thank you again for choosing IDEAL Door!

*Sincerely,
IDEAL Door*



Table of Contents

Introduction and Opening Preparation

Safety Information	3
Things to Know Before You Begin	4
Removing the Existing Door	5
Preparing the Opening	5

Installing the New Door

Preparing and Installing Door Sections	7
Door Reinforcement Attachment	9
Full Vision Doors & Sections	11
Track Installation	13
Spring Installation	19
Spring Winding	22

Maintenance/Adjustments/Options

Final Adjustment and Maintenance	26
Painting.....	26
Window Replacement.....	26
Attaching an Automatic Opener.....	27
Special Components	28

SAFETY INFORMATION

IMPORTANT!



To Protect Yourself from Injury, Carefully Read the Following Safety Information and Warnings Before You Install or Attempt To Repair Your New Garage Door.



- You can install your new garage door yourself IF...
 - a) you have help (weight can vary from 150 lbs. [70 kg] up to 2,000 lbs. [900 kg]);
 - b) you have the right tools and reasonable mechanical aptitude or experience; and
 - c) you follow these instructions very carefully.In Particular, please note that:
- Garage doors use springs to balance them. Generally, there are two types of springs used – **extension or torsion springs**. **If your old door uses torsion springs, do not attempt to remove the door or the springs yourself.** Have a qualified door repair service remove them. Attempting to remove a torsion spring assembly and/or any red-colored fasteners without proper training or tools may result in an uncontrolled release of spring forces which can cause serious or fatal injury.
- The brackets at the bottom corners of your garage door are under great tension. **Do not attempt to loosen any bracket fasteners** and/or any red-colored fasteners except when and as directed in detail in the following instructions. Otherwise, the bracket could spring out with dangerous force.
- When installing a door with torsion springs, always use solid steel winding bars. Winding bars are available from many professional door installers. **The use of screwdrivers or any substitutes for winding bars will risk severe injury.** See "Spring Winding" for further safety instructions regarding winding bars.
- Keep hands and fingers clear of section joints, track, and other door parts when the door is opening and closing to avoid injury. The lift handle and pull down rope are located for safe operation as well as easy use.
- **Extension spring doors must never be operated without a properly installed spring containment cable.**
- 3/8" [10 mm] Hex Head Bolts must be installed at the rear end of horizontal tracks. These act to stop the rollers and keep the door from rolling off the back of the track.
- **Only the track and hardware specified and supplied with the door should be used.**
- Express warranties apply only to doors installed using original, factory-supplied sections, parts, and hardware installed in strict accordance with these instructions.
- Track installations must use sway braces on the rear track hangers to prevent sideways movement. If the tracks are not firmly stabilized they might spread, allowing the door to fall and cause severe injury and damage.
- The torsion spring assembly uses one (1) wooden pad (2" x 6" x 12" [51 mm x 152 mm x 305 mm] minimum) or steel plate (1/4" x 10" x 12" [6 mm 254 mm x 305 mm] minimum) per spring anchor bracket, that **must be of good quality and firmly attached to the wall.** Four 3/8" x 3" [10 mm x 76 mm] lag screws should be used to attach to a wood structure. The wood needs to be made of a Grade 2 or better Southern Yellow Pine (also known as Southern Pine or Yellow Pine.) **DO NOT** use wood labeled as Spruce-Pine-Fir (or SPF). Four 3/8" [10 mm] masonry anchors can be used on concrete or block walls. If the wood splits once the torsion spring is in place, it should be replaced by a professional installer. **Do not try to remove or repair a torsion spring assembly or any red-colored fasteners once it is wound.**
- **Springs, cables, and bottom brackets are under extreme spring tension. Do not attempt to loosen any fasteners on these components.** You could suddenly release spring forces and risk severe injury.
- If the garage door and/or any of the supporting track are damaged, operating the door could be hazardous. Call an authorized representative of the manufacturer or professional door repair service promptly.
- **Do not permit children to play beneath or with any garage door or electric operating controls.**
- If repairs are ever required to your door, safety and trouble-free operation can be best assured by using original replacement parts.
- Once you have completed the installation of your new garage door, please be sure that your garage complies with all applicable ventilation requirements before you enclose any vehicles in the garage. Good ventilation avoids fire and health hazards caused by fumes accumulating within a well-sealed garage.
- The manufacturer disclaims all liability for any installation which is not in compliance with applicable state, county, or local building codes.
- Doors equipped with automatic door operators can cause serious injury or death if not properly adjusted and operated. To insure safe operation of these doors:
 - a) test the sensitivity of the operator's safety reverse mechanism monthly;
 - b) remove the pull rope;
 - c) make sure the door remains unlocked;
 - d) do not allow children to play with the controls.
 - e) do NOT install jackshaft openers on doors with standard lift or low headroom track.

Things to Know Before You Begin

Read the instructions completely before starting installation of the door. Becoming familiar with the components before assembling the door will reduce the installation time.

⚠ WARNING

In the interest of safety this symbol means **WARNING** or **CAUTION**. Personal injury and/or property damage may occur unless instructions are followed carefully.

- To avoid damage to the door, you must reinforce the top section of the door in order to provide a strengthened mounting point for attachment of an automatic opener. Refer to "Attaching an Automatic Opener".
- Check clearance requirements in the chart below before beginning.

⚠ WARNING

Springs and related hardware are under **EXTREME** tension and could cause **SEVERE INJURY OR DEATH** if mishandled. **DO NOT ATTEMPT TO REPAIR OR ADJUST** the springs, red fasteners, hardware, or structure to which they are attached.

IMPORTANT!

Before Starting Installation:

Step 1: Check the opening size and verify that the door is the proper size for the opening. Wood jambs require the door to be the same size as the opening with stop moldings nailed to the inside of the opening to seal the door. Steel or masonry jambs require the door to be two-inches wider than the opening to allow a one-inch door overlap on each side. No stop moldings are required in this application. The opening must be plumb and square to assure a good fit.

Step 2: Check all materials with the hardware box & spring box labels. Any report of shortages must be accompanied by the contract number. Report the number of pieces received along with the number of pieces short. Springing information, including the number of turns to wind spring, can be found on the hardware box label.

Step 3: Check for sufficient headroom and side room. The chart below contains standard minimum clearance requirements. Headroom is the distance between the top of opening to the ceiling or the lowest obstruction.

Step 4: The hardware package supplied with your door should include red fasteners for attachment of the torsion spring center bracket and/or the bottom roller brackets. These fasteners must be securely attached as indicated in the installation manual.

Standard Minimum Clearance Requirements

	Headroom*, **, ***		Sideroom*		Backroom	
	2" [51 mm] Track	3" [76 mm] Track	2" [51 mm] Track	3" [76 mm] Track	2" [51 mm] Track	3" [76 mm] Track
12" [305 mm] Radius	14-1/2" [368 mm]	N/A	4-1/2" [114 mm]	N/A	Door Ht.+ 23" [584 mm]	N/A
15" [381 mm] Radius	16" [406 mm]	18" [457 mm]	4-1/2" [114 mm]	5-1/2" [140 mm]	Door Ht.+ 23" [584 mm]	Door Ht.+ 25" [635 mm]
Low Headroom Rear Torsion	6-1/2" [165 mm]	10" [254 mm]	6" [152 mm]	6-1/2" [165 mm]	Door Ht.+ 30" [762 mm]	Door Ht.+ 32" [813 mm]
Low Headroom Front Torsion	10" [254 mm]	13" [330 mm]	6" [152 mm]	6-1/2" [165 mm]	Door Ht.+ 23" [584 mm]	Door Ht.+ 25" [635 mm]
High Lift	High Lift + 12" [305 mm]	High Lift + 12" [305 mm]	4-1/2" [114 mm]	5-1/2" [140 mm]	Varies	Varies
Vertical Lift	Dr. Ht. + 12" [305 mm]	Dr. Ht. + 12" [305 mm]	4-1/2" [114 mm]	5-1/2" [140 mm]	23" [584 mm]	25" [635 mm]

* Doors over 18' [549 cm] high, over 1,000 lbs. [454 kg] springing weight or high cycle springs may require additional headroom and sideroom. Consult distributor for exact requirements.

** Doors with more than one row of springs require additional headroom.

*** Chain hoist and electric operators require additional clearance. See instructions provided with operator for exact amount.

*** Vertical lift doors with straight incline require additional headroom. Contact factory.

Tools Needed

- “C” Clamps or Locking Pliers
- Hammer
- Winding Bars (Torsion Only)
- Screwdriver
- Tape Measure
- Level
- Socket wrench kit
- Pliers
- Drill, and 1/4" [6 mm], 3/16" [5 mm], & 3/8" [10 mm] bits
- Ladder
- Saw horses or other supports for placing section on while assembling
- Pencil/Pen/Marker
- Chalk/Chalk Line

Removing the Existing Door

⚠ WARNING

Garage doors use springs to balance the door weight. Generally there are two types of springs used - extension springs and torsion springs. **If your present door uses torsion springs, have a qualified door service professional remove them.** Attempting to remove a torsion spring assembly without proper training and tools may result in an uncontrolled release of spring forces which can cause serious or fatal injury.

Preparing the Opening

Step 1: On the inside of your opening should be framed with wood jambs, 2" x 6" [51 mm x 152 mm] if possible, or with steel channel. The side jambs should extend to approximately the same height as the headroom required. If you have just removed an old door, the condition of the jambs should be inspected. If the jamb has deteriorated, it should be replaced now. The jambs should be plumb and the header level. If there are any bolts fastening the jambs to the wall, the heads should be flush so they don't interfere with the installation of your new door. (Fig. 1-J) Typical installation for wood, steel or masonry jamb material is shown in Fig. 2-J.

Step 2: Door stop molding for wood jambs should be temporarily nailed to the edges of the jambs flush with the inside. (Fig. 3-J) Since steel jambs require the door to be 2" (51 mm) wider than the opening, no stop molding is required. Stop molding featuring a built in weather seal is offered as an option.

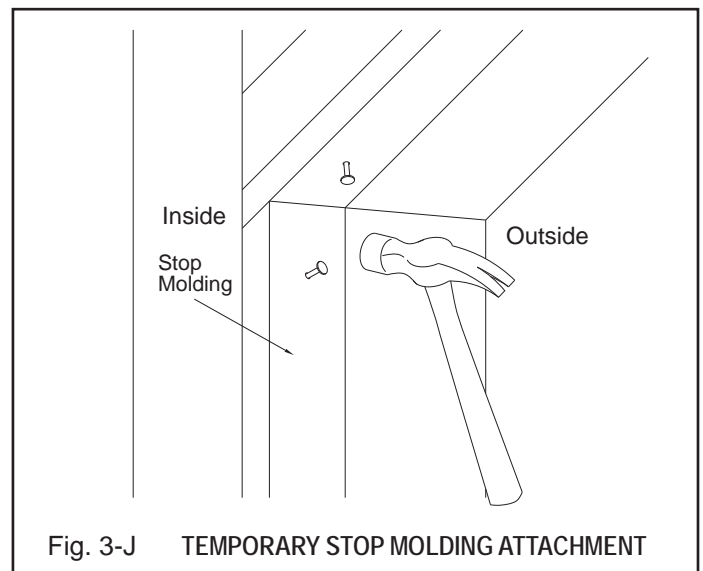
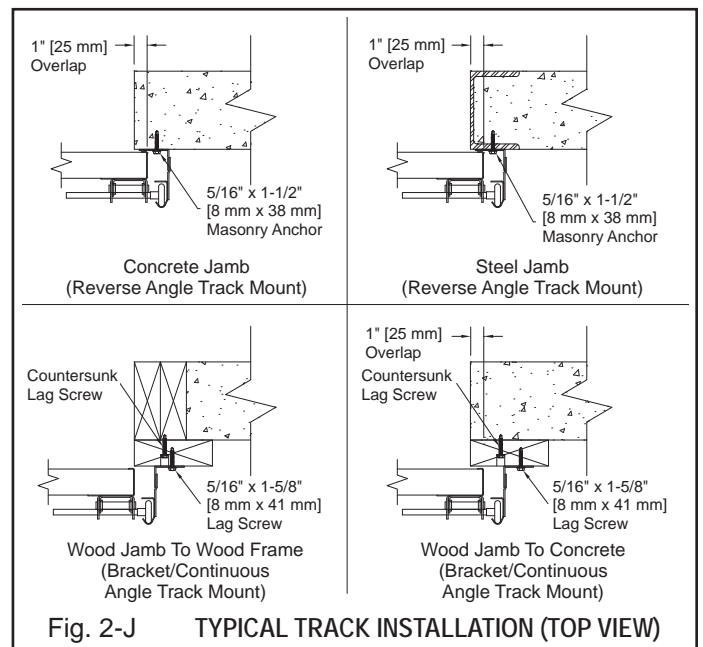
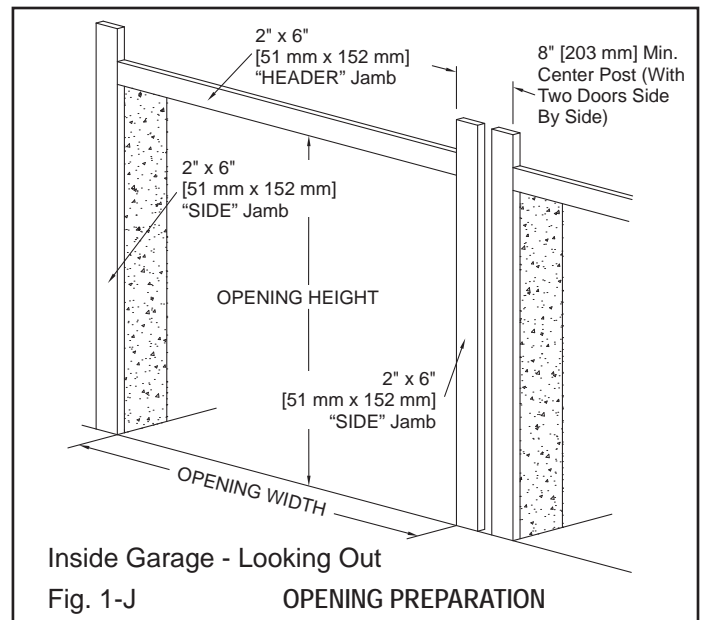

WARNING

Red-colored fasteners must be used for attachment of the bottom roller brackets on commercial doors.

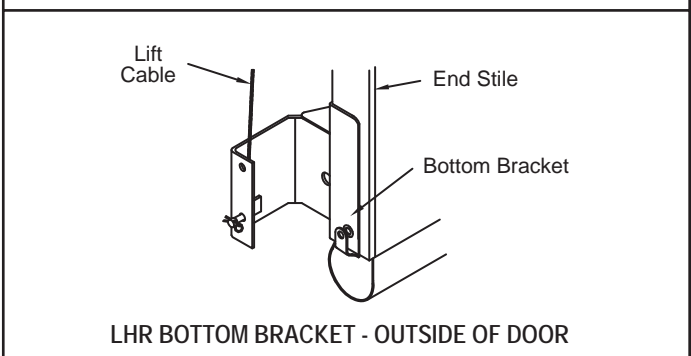
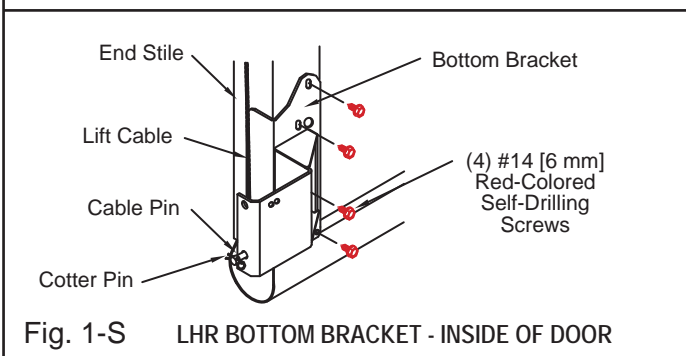
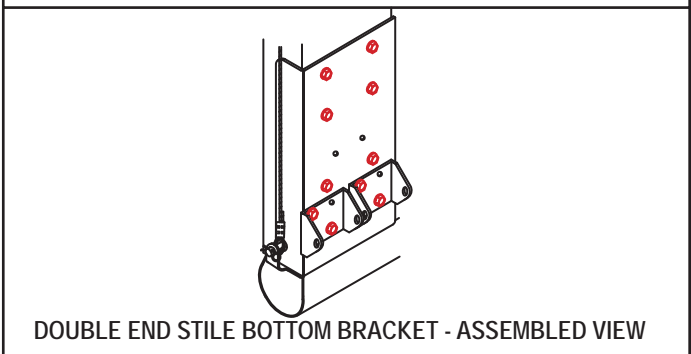
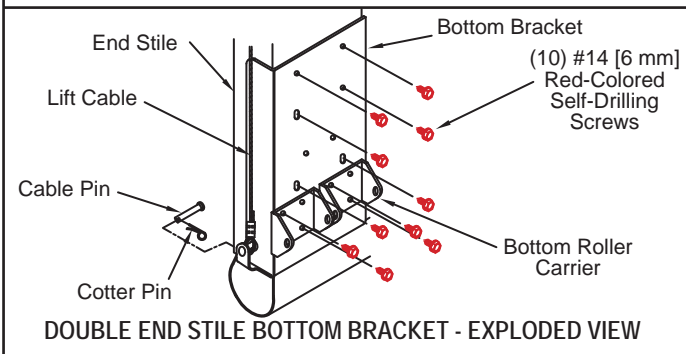
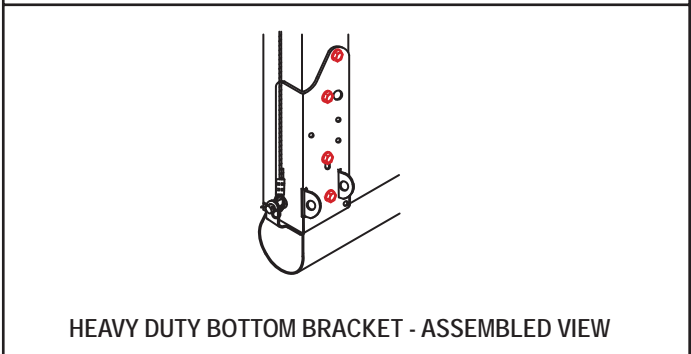
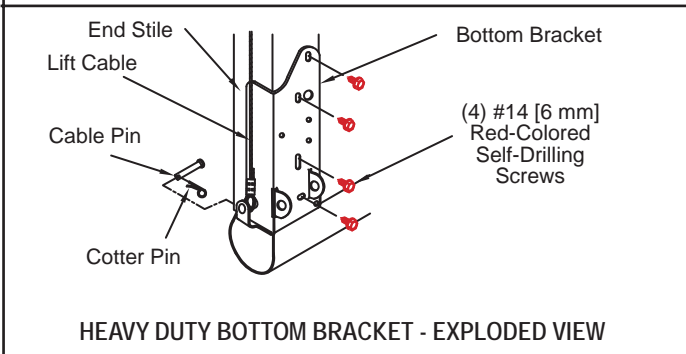
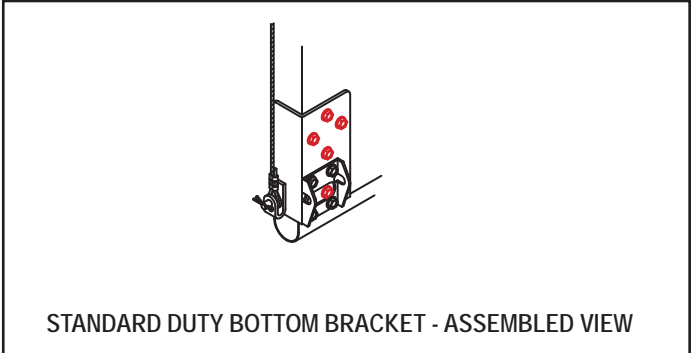
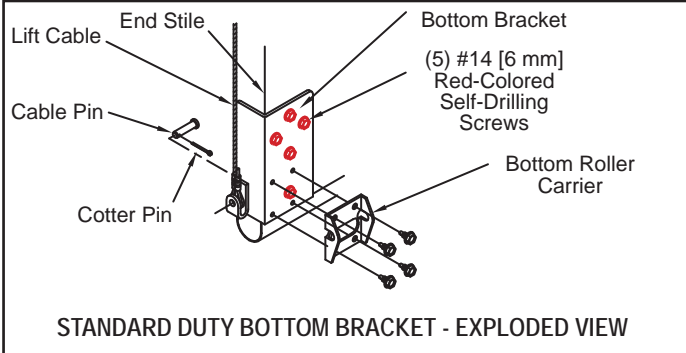
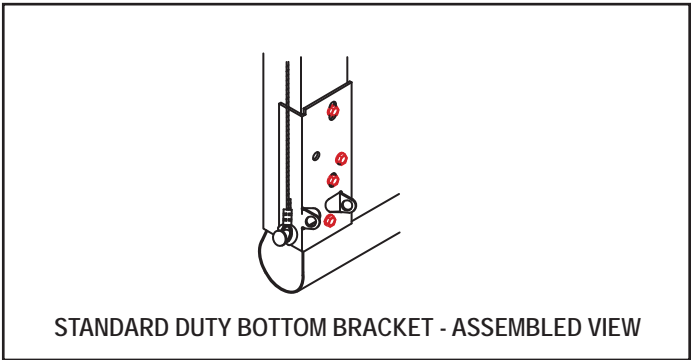
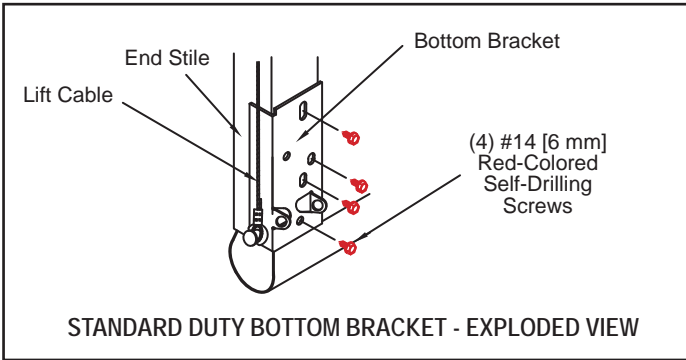

Preparing and Installing Door Sections

Step 1 : Bottom Section. Find bottom section (the one with bottom weatherseal), then lay it face down on saw horses ensuring it is properly supported. Find bottom bracket in hardware carton. Several different types are used depending on door thickness, door weight, and track size. Fasten bottom bracket using the red colored fasteners. (Fig. 1-S)

Some have flanges which hook under the bottom section and some do not. If the bracket has a flange, slit the inside leg ONLY of the bottom weatherseal approx. 1-1/2" [38 mm] to allow for bracket attachment. Install cables on bottom bracket, then position the bracket in place. (Fig. 1-S)

IMPORTANT: Do not cut cables. It may seem like the cables are too long, but they are not. Wind the extra cable onto the drums.

Install hinges on end and center stiles of the bottom section using #14 x 3/4" [6 mm x 19 mm] self-drilling screws. See Fig. 2-S for sequence and hinge placement.

For Insulated Sandwich Doors under 22' 2" Wide, Utilizing C-Channel or T-Strut Only: Before hinge installation, wipe down area at each center hinge location with rubbing alcohol, tear the liner off the adhesive on provided external backer strip, and apply external backer strip vertically across the section at each center hinge location. For Full Vision/Aluminum doors and doors with Full Vision Sections, refer to "Full Vision Doors & Sections".

Install reinforcement strut, if supplied. Refer to "Door Reinforcement Attachment" for instructions. Stack bottom section in opening. **Long stem rollers provided go into bottom brackets.** Temporarily install vertical track as described in "Track Installation". Top rollers will hold section in place.

Step 2: Step Plate/Lift Handle installation. Locate the step plate/lift handle on the upper portion of either bottom bracket and attach with (2) #14 x 3/4" [6 mm x 19 mm] self-drilling screws. (Fig. 3-S) Mount the rolled grip lift handle in line above the step plate using (2) #14 x 3/4" [6 mm x 19 mm] self-drilling screws. Orient the handle vertically on the end stile a minimum 7" [178 mm] from any door section joint.

HINGE ILLUSTRATION & ROLLER PLACEMENT

#1 HINGE

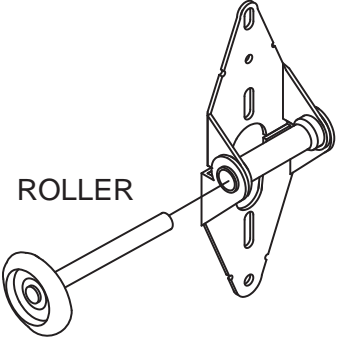

ROLLER

#2, 3, 4 HINGES

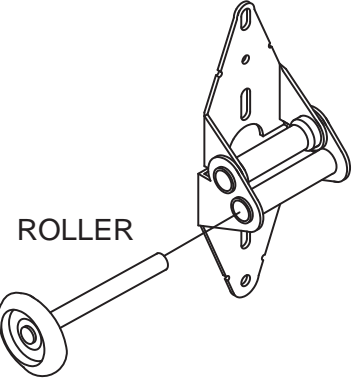

ROLLER

- All center hinges are #1 hinges (except for full view sections, and Full View Doors).
- Start end hinge sequence at the top of bottom section
- Double end hinges use the same # hinge as outside end hinges.
- Rollers in end hinges will use farthest sleeve from section.
- Non-standard tracks may require a different hinge pattern.

	End Hinge Top of Each Section				
	Bottom Section	#2 Section	#3 Section	#4 Section	#5 Section
2" [51 mm] Track	#1	#2	#3	#4	Continue in this manner
3" [76 mm] Track	#3	#4	#5	#6	Continue in this manner

SIDE VIEW
HINGES ARE TALLER WITH
INCREASING NUMBER

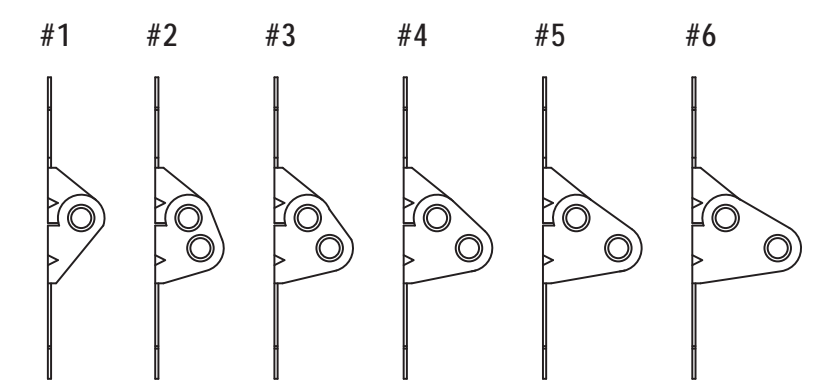

Fig. 2-S

7

Step 3: #2 Section. Attach bottom half of center hinges to top of section using #14 x 5/8" [6 mm x 16 mm] hex head sheet metal screws. Attach end hinges. (Fig. 2-S) Attach reinforcement strut, if supplied. Refer to "Door Reinforcement Attachment" for instructions. If section has lock see Step 4 for sequence. Stack section. After section is stacked, rollers in the track will hold section in place.

Step 4: Lock Installation. The standard location for the locking system (if provided) is on section #2 & should be installed prior to stacking additional sections. The following locking systems are available for commercial steel doors:

- Keyed Slide Lock
- Inside Slide Bolt

Side Locks: Unless otherwise specified at time of order, the stile to mount the side lock will be located 18" [457 mm] in from the right hand side of the door. Hole will be pre-drilled.

For side locks follow instructions provided with the locking mechanism.

Inside Slide Bolt: Locate rectangular engaging slots in either vertical track.

Attach inside bolt assembly to end stile using #14 x 5/8" [6 mm x 16 mm] hex head sheet metal screws. The slide bolt must rest against the top of the engaging slot (Fig. 4-S).

Step 5: #3 Section & Up (Does not include Top Section). Place section face down on saw horses. Attach bottom half of center hinges to top of section using #14 x 5/8" [6 mm x 16 mm] hex head sheet metal screw. Attach end hinges. (Fig. 2-S). Attach reinforcement strut, if supplied. Refer to "Door Reinforcement Attachment" for instructions. After section is stacked, rollers in the track will hold section in place.

Continue to stack and install remaining sections in the same manner as described above until all but the top section are properly in place.

Step 6: Top Section. Place top section face down on saw horse. Place top brackets over pre-punched holes so they are flush with edge of section. Center of roller carrier will be about 4" [102 mm] down from top of section. Using #14 x 5/8" [6 mm x 16 mm] hex head sheet metal screws, attach top brackets to section. (Fig. 5-S) (Low headroom doors 3/4 [19 mm].)

Install reinforcement strut/channel, if supplied. Refer to "Door Reinforcement Attachment" for instructions.

Stack top section after all tracks are installed, but before springs are wound.

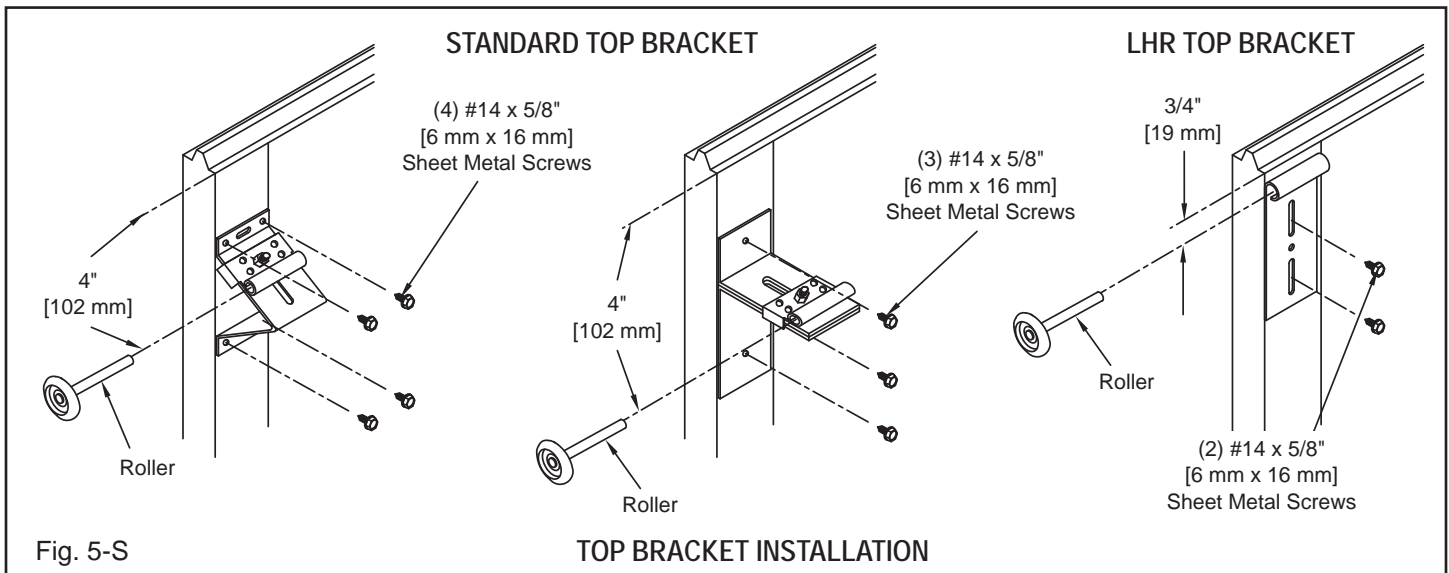
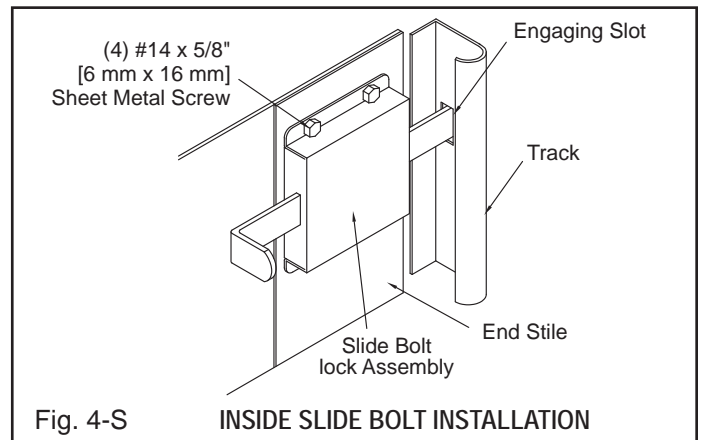
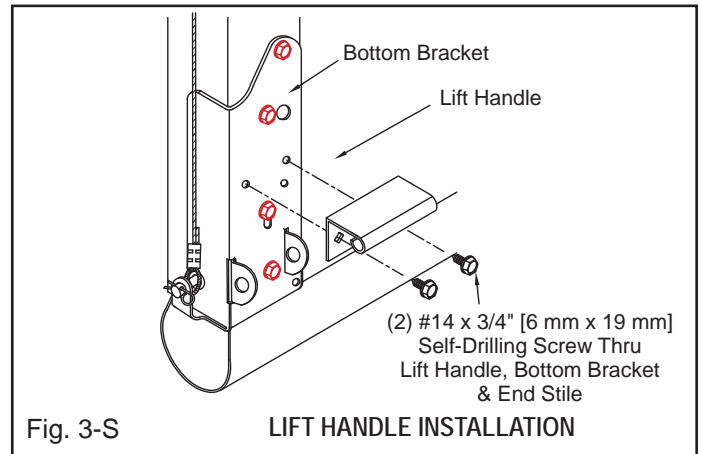

Door Reinforcement Attachment

NOTE: All doors do not require reinforcement, follow instructions listed below according to the number of struts/channels supplied.

- Number of struts/channels will be shown on hardware box.
- All struts/channels are attached with #14 x 3/4" [6 mm x 19 mm] self-drilling screws to center stiles and end stiles.
- When only one U-strut is supplied it is to be mounted on the top section.
- When an equal number of struts/channels and sections are supplied, install one on each section.
- If your door contains less U-struts than sections, evenly distribute the struts, starting from bottom to top.
- When there is one more U-strut provided than the number of sections this strut is to be mounted on the

bottom section over the bottom bracket as shown in illustration.

- Doors installed in high windload regions (Florida and other hurricane prone areas) may require additional reinforcement beyond what is detailed in this manual. Please refer to windload drawings.

U-Strut Attachment

(Non-Windload Doors Only)

With section face down on saw horses, place strut at the top of the sections and center it (Fig. 6-S).

Attach each end of strut to end hinges, then to center hinges.

Top section strut is to be mounted with top edge of strut 1/4" [6 mm] down from top of door and above top bracket, as illustrated - except on low headroom installations, refer to "Top Section Strutting for LHR".

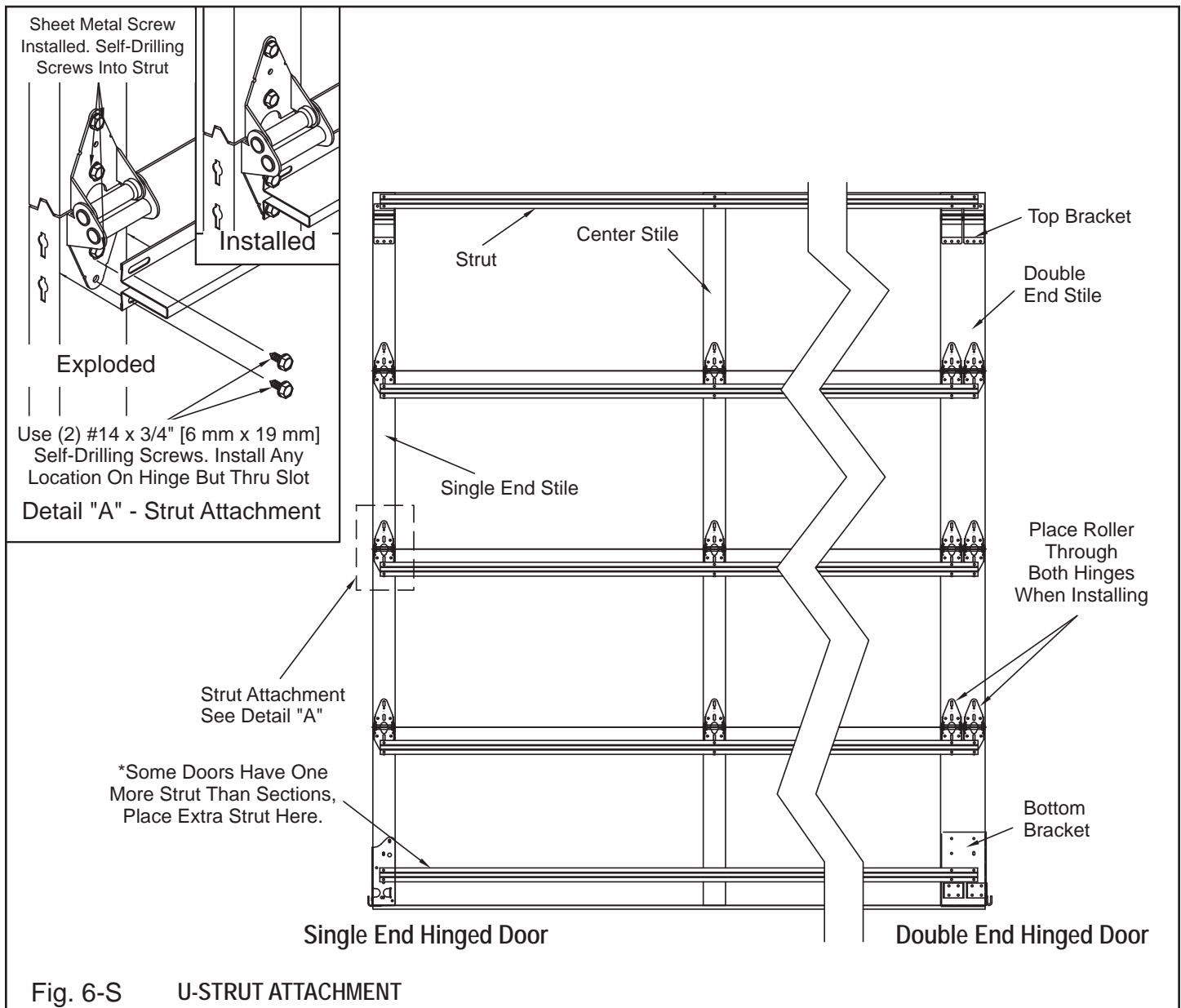

Fig. 6-S U-STRUT ATTACHMENT

C-Channel Attachment (Non-Windload Doors Only)

With section face down on saw horses, place C-Channel in the middle of section, with open end facing the bottom of the section. (Fig. 7-S)

Using the access holes at each end, attach C-Channel to end stiles using #14 x 3/4" [6 mm x 19 mm] self-drilling screws.

Attach C-Channel Straps to the channel and each center stile/external backer strip using self-drilling screws. Single end stiles require (1) strap, double end stiles require (2) straps.

On Top and Bottom Insulated Sandwich Sections Only: Inset one #14 x 3/4" [6 mm x 19 mm] Self-Drilling Screw at the top/bottom of each backer strip to secure it to the section.

T-Strut Attachment (Non-Windload Doors Only)

With section face down on saw horses, place T-strut in the middle of the section and center it. (Fig. 8-S)

Attach strut to each end stile first, then attach to center stiles/external backer strips using self-drilling screws.

On Top and Bottom Insulated Sandwich Sections Only: Inset one #14 x 3/4" [6 mm x 19 mm] Self-Drilling Screw at the top/bottom of each external backer strip to secure it to the section.

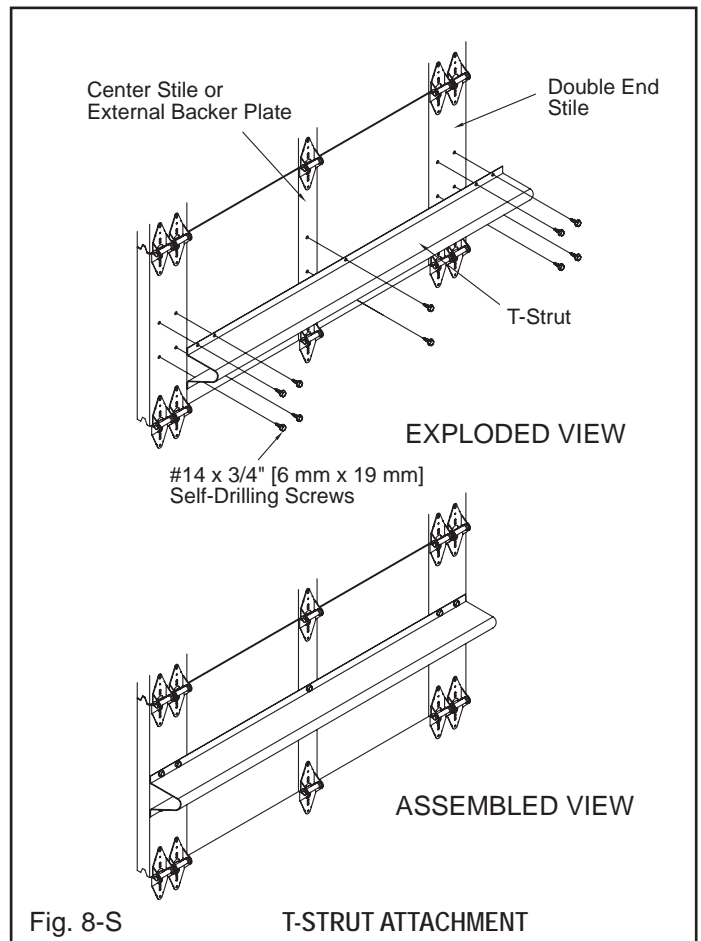
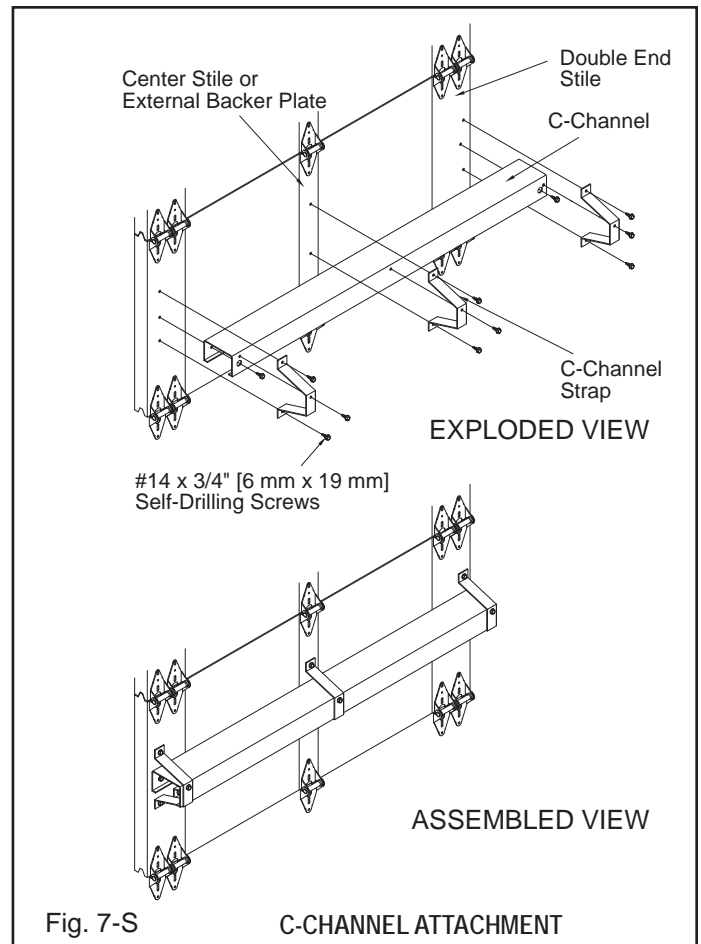

Top Section Strutting Procedure for LHR

With the top section face down on saw horses, place strut on top of section (section should be flat). Position top edge of strut approximately 1" [25 mm] down from top of door. At each center stile, fasten strut to center stile with (2) #14 x 5/8" [6 mm x 16 mm] self-drilling screws. The ends of the struts will require fastening in the same manner as the center stiles after the section has been installed and top brackets have been installed and adjusted.

Full Vision Doors & Sections

If your door has been furnished with one or more full vision sections, please refer to Fig. 9-S for identification of the special hinge parts which must be used.

End hinges are of the same type and follow the same sequence as described in the general instructions (Fig. 2-S). The standard #14 x 5/8" [6 mm x 16 mm] hex head sheet metal screws are used to fasten the end hinges to the full vision section.

If your door has a full vision top section, it is very important that each top roller bracket be attached to the reinforcing fins in the top rail and the end stile. Two #14 x 3/4" [6 mm x 19 mm] self-drilling screws should fasten the top of each bracket to the top rail and one screw should attach the bottom of the roller bracket to the end stile.

Remember: The small indentations that run the length of the top rail and end stile mark where the reinforcing fins are located. (Fig. 10-S)

For attachment of center hinges, proceed as follows:

Refer to Fig. 9-S for identification of proper center hinges and the positions in which they are to be installed. Note that the #14 x 3/4" [6 mm x 19 mm] self-drilling screws are used to attach the center hinge to the bottom rails and the 1/4" x 3/4" [6 mm x 19 mm] hex bolts and 1/4" [6 mm] hex nuts are used to attach the center hinge to the fin of the upper rail. (Fig. 11-S) Special attention must be given to this step of the procedure since proper placement of hinges is critical to installation of the door.

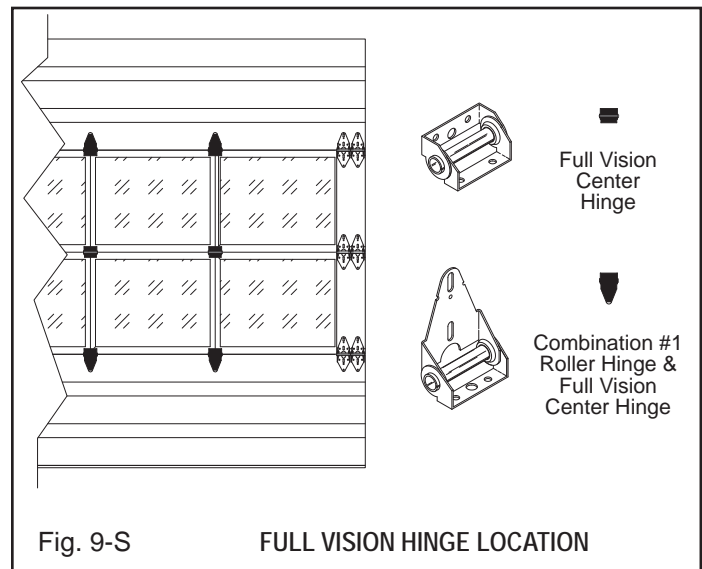

Fig. 9-S

FULL VISION HINGE LOCATION

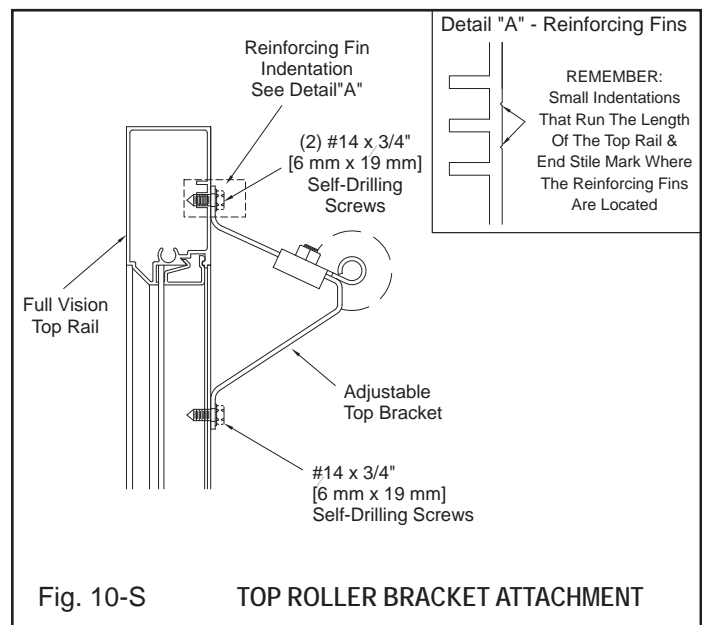

Fig. 10-S

TOP ROLLER BRACKET ATTACHMENT

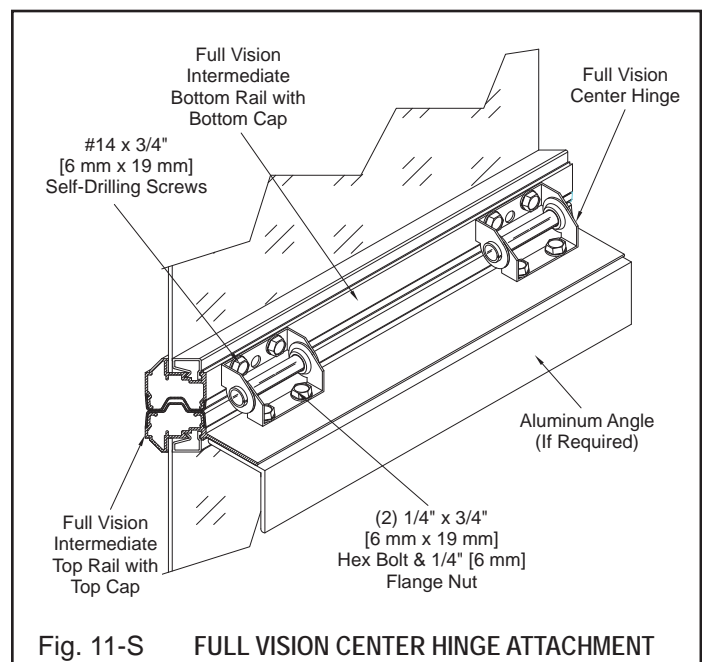
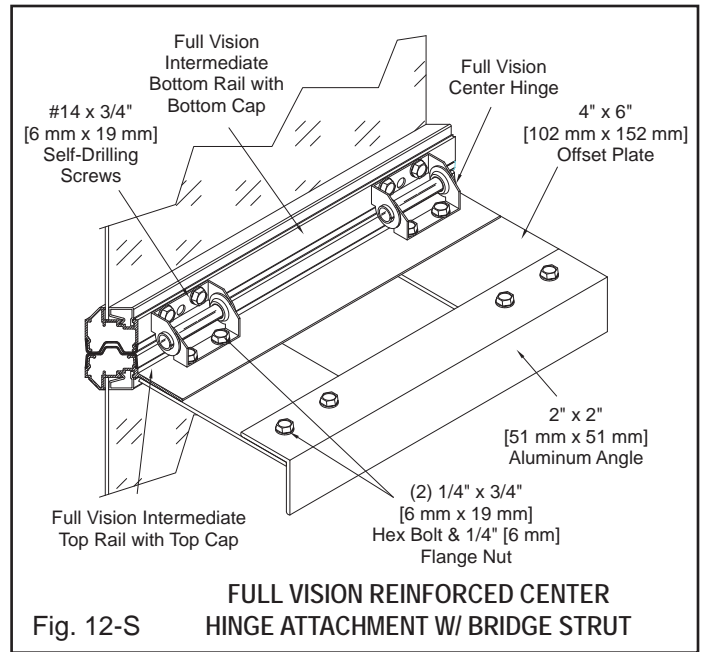

Fig. 11-S

FULL VISION CENTER HINGE ATTACHMENT

Refer to Fig. 11-S, Fig. 12-S & the Reinforcement Schedule for reinforcement of full vision sections. After full vision sections are in place, refer to the general instructions for completion of your installation.

Sometimes, higher than standard wind loading requires a bridge strut (2" x 2" [51 mm x 51 mm] aluminum angle with offset plates). (Fig. 12-S)



Reinforcement Schedule for Aluminum/Full Vision Sections

Door Width	What is Needed For 1/8" [3mm] Thick Glazing
Up to 11'2" [340 cm]	None
11'3" to 12'2" [345 cm to 371 cm]	None
12'3" to 14'2" [373 to 432 cm]	One 1-1/4" x 1-1/4" x 1/8" angle per section (32 mm x 32 mm x 3 mm)
14'3" to 15'2" [442 cm to 462 cm]	One 1-1/4" x 1-1/4" x 1/8" angle per section [32 mm x 32 mm x 3 mm]
15'3" to 16'2" [465 cm to 493 cm]	One 1-1/4" x 1-1/4" x 1/8" angle per section [32 mm x 32 mm x 3 mm]
16'3" to 18'2" [495 cm to 554 cm]	One 2" x 2" x 1/8" angle per section [51 mm x 51 mm x 3mm]
18'3" to 20'2" [556 cm to 615 cm]	One 2" x 2" x 1/8" angle per section [51 mm x 51 mm x 3mm]
20'3" and Over [617 cm]	One Bridge Strut per section
Door Width	What is Needed For 1/4" [6mm] Thick Glazing or IG Glazing
Up to 11'2" [340 cm]	None
11'3" to 12'2" [345 cm to 371 cm]	One 1-1/4" x 1-1/4" x 1/8" angle per section (32 mm x 32 mm x 3 mm)
12'3" to 14'2" [373 to 432 cm]	One 1-1/4" x 1-1/4" x 1/8" angle per section (32 mm x 32 mm x 3 mm)
14'3" to 15'2" [442 cm to 462 cm]	One 2" x 2" x 1/8" angle per section [51 mm x 51 mm x 3mm]
15'3" to 16'2" [465 cm to 493 cm]	One 2" x 2" x 1/8" angle per section [51 mm x 51 mm x 3mm]
16'3" to 18'2" [495 cm to 554 cm]	One Bridge Strut per section
18'3" to 20'2" [556 cm to 615 cm]	One Bridge Strut per section
20'3" and Over [617 cm]	One T-Strut or C-Channel per Section

Track Installation

General Information. There are three basic pieces of information about your tracks that you need to know to start installation.

- 1) **Track size** - Track comes in two sizes: 2" [51 mm] and 3" [76 mm].
- 2) **Type of lift** - Each type of lift is different from the top of the door on up. However, the vertical track from the floor to the top of the door does not change between the different lift options. (Fig. 1-T) Therefore, the vertical track instructions to the top of the door are explained in one group (Step 1). Then turn to your specific type of lift for completion of the installation.

- 3) **Type of mounting** - Bracket mounting is used on lighter doors with wood jambs. Brackets are loose or riveted into place. Loose brackets are attached to the track with (1) 1/4" x 5/8" [6 mm x 16 mm] track bolt and nut per bracket. Continuous angle and reverse angle track are shipped with mounting angle attached. **Loosen nuts on track bolts so track will slide on the angle, in order to adjust track as needed.** (Fig. 1-T)

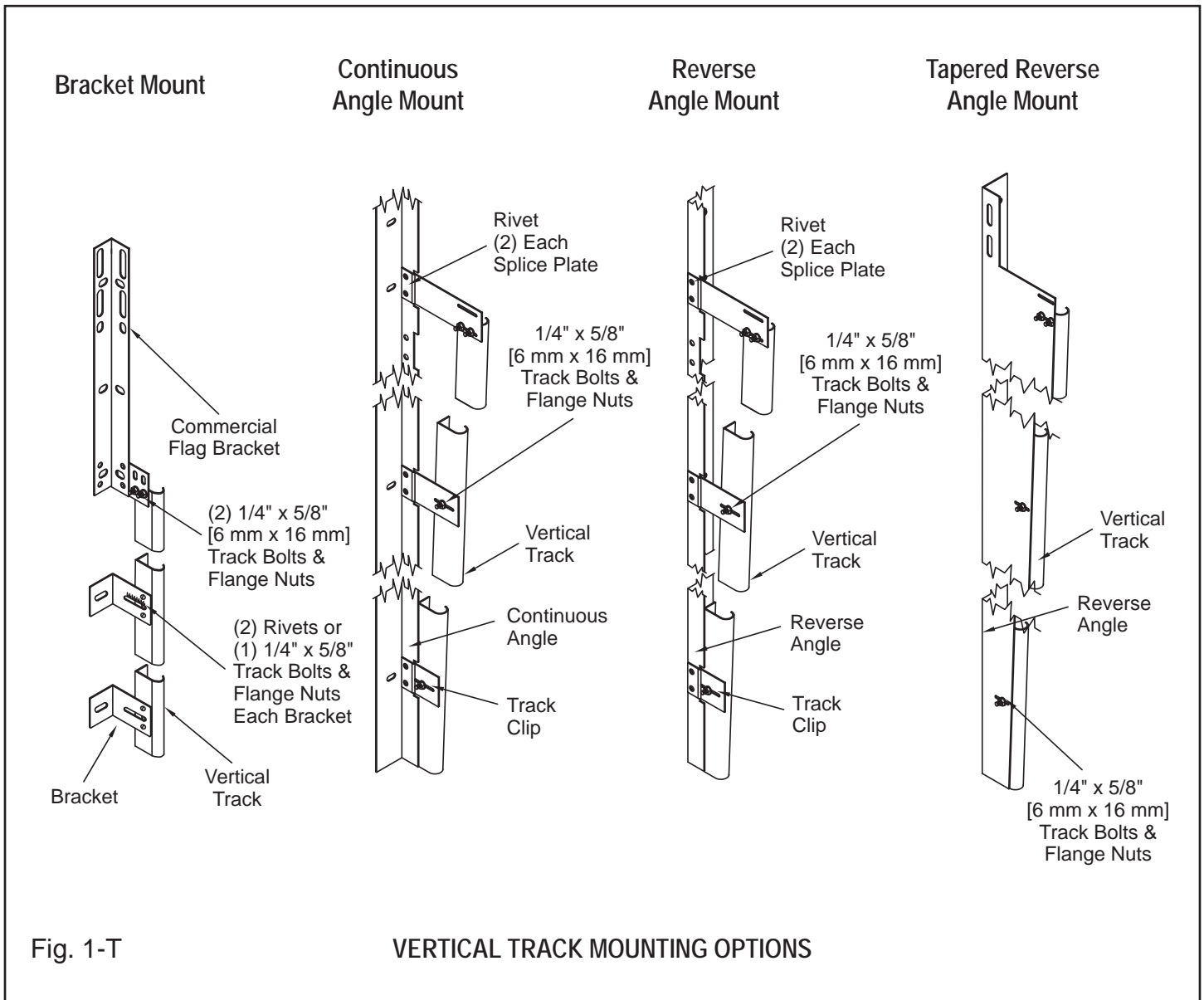

Step 1: Vertical Track. Center bottom section in opening on inside of garage. Level section by shimming low side. (Fig. 2-T) Leave shims in place until door install is completed. Install the vertical track on opposite side of where block was placed, over the two rollers of the bottom section with a twisting motion. (Fig. 3-T) Raise track 1/2" [13 mm] off the floor, and screw 5/16" x 1-5/8" [8 mm x 41 mm] lags (wood jambs), or self-drilling screws (steel jambs) through bottom mounting bracket. (Fig. 4-T) Adjust track sideways to allow 1/4" [6 mm] end play in roller about 1/2" [13 mm] (2" track) or 3/4" [19 mm] (3" track) from edge of track to edge of door. (Fig. 2-T) Plumb vertical track and put at least two lags or sheet metal screws in the mounting brackets at the top of the door. Final adjustment will be made after door is stacked. Measure from the top of the vertical track to the top of the bottom section and set the opposite track at exact same height repeating above procedure. (Fig. 2-T) Since the bottom section is level, then the vertical tracks must be level. **Make sure bottom rollers do not come out of the bottom of the track.**

Step 2: Stacking. Refer to "Preparing & Installing Door Sections" for stacking instructions

Step 3: Finishing Vertical Track. Set the top of the vertical tracks so that there is 1/4" [6 mm] end play in the rollers, about 1/2" [13 mm] (2" track) or 3/4" [19 mm] (3" track) from edge of track to edge of door. (Fig. 2-T) Finish attaching vertical track to the wall. If you are mounting to steel jambs, you will have to wait until you can raise the door to finish attaching vertical tracks.

NOTE: To complete the rest of the track installation, refer to the page explaining your specific lift option:

- Standard Lift.....Page 15
- Roof Pitch.....Page 16
- Low Headroom Double Track.....Page 16
- Vertical Lift.....Page 17
- High LiftPage 18

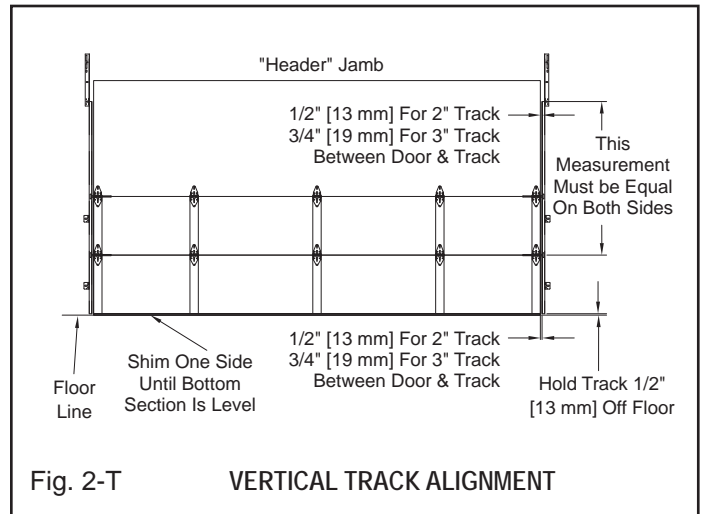

Fig. 2-T VERTICAL TRACK ALIGNMENT

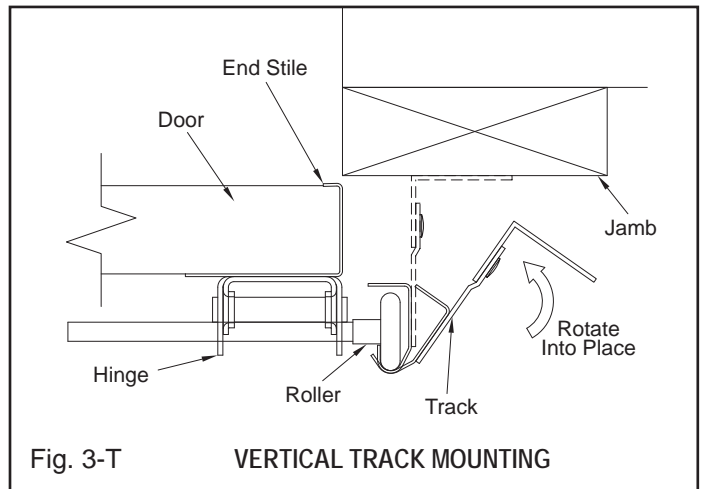

Fig. 3-T VERTICAL TRACK MOUNTING

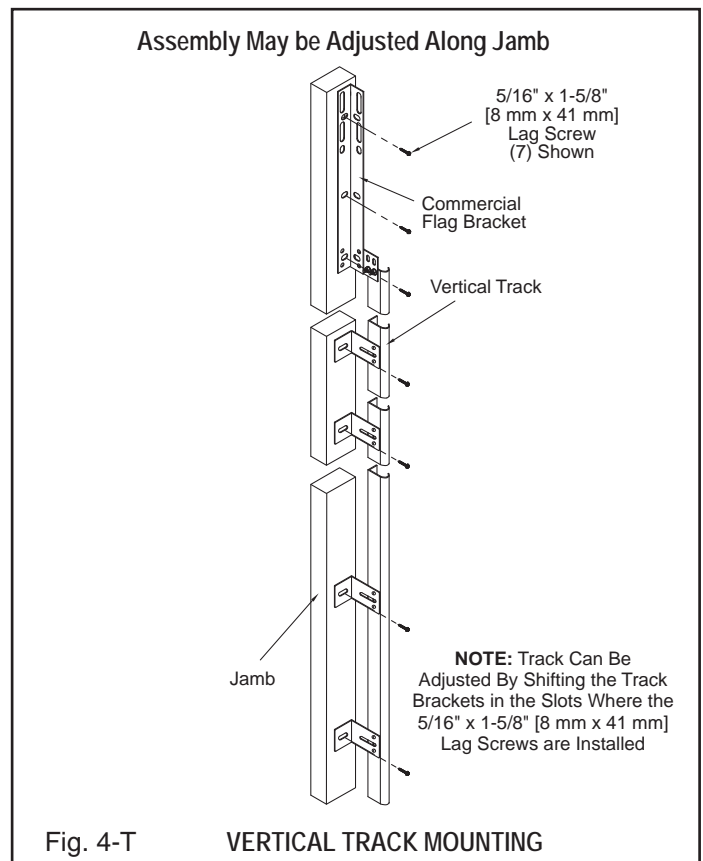

Fig. 4-T VERTICAL TRACK MOUNTING

IMPORTANT:

Backhang Requirements

IMPORTANT NOTE: All doors with horizontal track over 12' [366 cm] require one backhang & one center hang, minimum. Doors with horizontal over 18' [549 cm] require one backhang & two center hangs, minimum. Backhangs & center hangs are evenly spaced on each horizontal track. (Fig. 5-T) Also, on low headroom track doors, all doors 12' [366 cm] high and under that are over 600 lbs. [272 kg] or have 1" [25 mm] of sag in horizontal track when the door is in full open position, will require two backhangs evenly spaced on each horizontal track. Inspection of horizontal track is required after completion of garage door installation. With the garage door in the full open position, there should only be 1/4" [6 mm] of free play in rollers and 1/2" [13 mm] (2" track) or 3/4" [19 mm] (3" track) from the edge of the horizontal track to the edge of the door. Realign tracks if necessary.

Standard Lift

Step 1: Horizontal track install. Attach horizontal track to commercial flag bracket using two 1/4" x 5/8" [6 mm x 16 mm] track bolts and flange nuts. Attach horizontal angle to commercial flag bracket using 3/8" x 3/4" [10 mm x 19 mm] carriage bolts and flange nuts. Temporarily set back hangs for horizontal track or rig a temporary rope to support back of horizontal track. They should be

level to 1" [25 mm] higher in the back, parallel to each other, and at right angles to the wall when completed. (Fig. 5-T)

Step 2: Top Section. Install top section now to other sections. Refer to "Preparing and Installing Door Sections" for instructions.

Step 3: Spring Installation. Install end bearing plates as shown. (Fig. 5-T) Refer to "Spring Installation" for additional instruction.

Step 4: Spring Winding. Refer to "Spring Winding" for instructions.

Step 5: Backhang Doors. After springs are installed and wound, release locking pliers and raise door **so that only the two top sections** are in the horizontal tracks. Secure door in place with locking pliers on vertical track above a roller, making sure it can't be raised, and align horizontal tracks. Backhang doors. (Fig. 5-T) **Any door over 12' [366 cm] high requires a center hang and a backhang on each horizontal track.** See "Backhang Requirements" for backhang requirements. All backhang material is supplied by the installer.

Step 6: Final Adjustments. Refer to "Final Adjustments & Maintenance" to finish install.

If a spring bumper is required refer to Fig. 11-T.

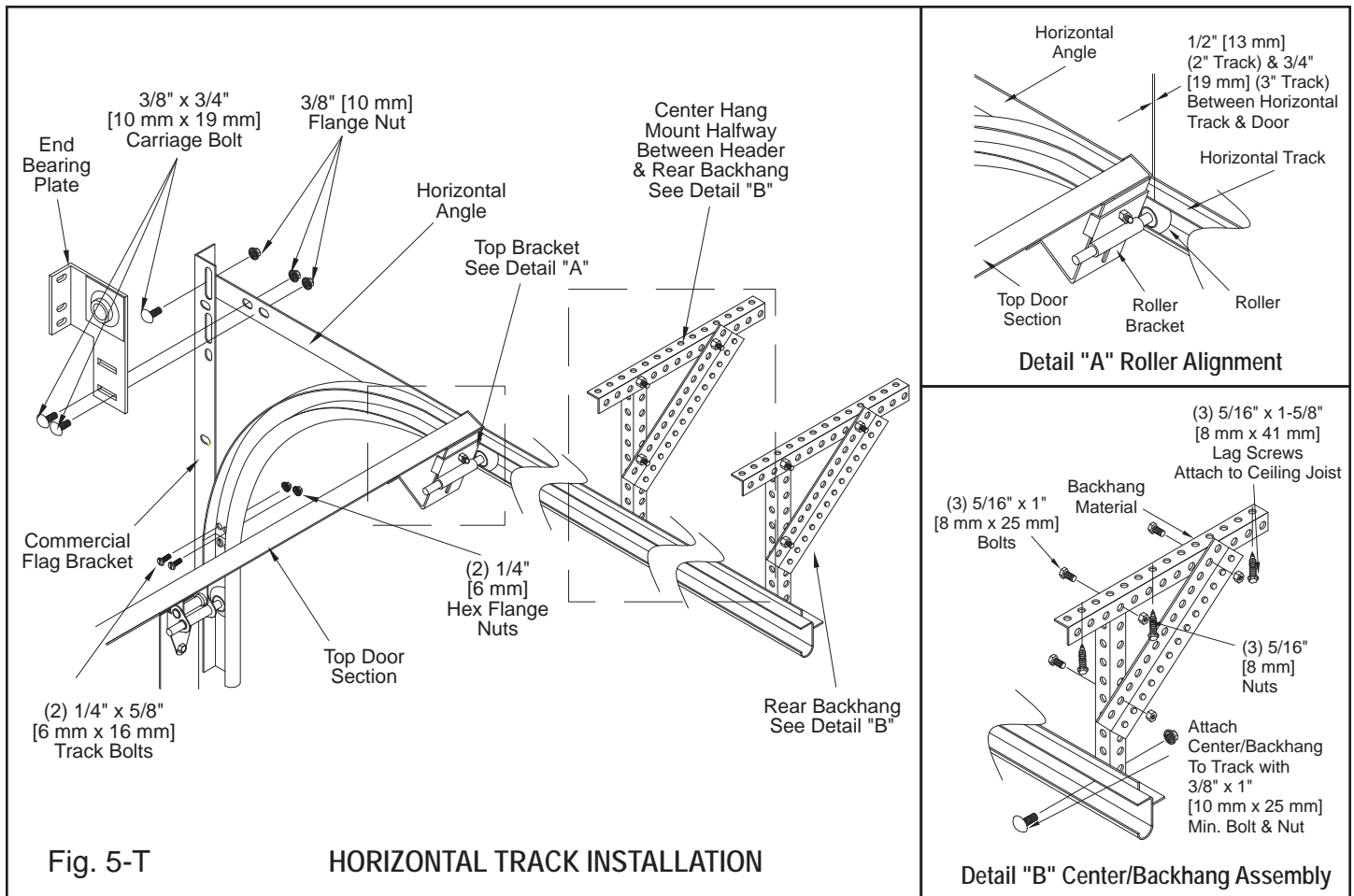

Roof Pitch

Step 1: Horizontal track install. Horizontal track follows the pitch of the roof line. An extension angle is mounted, level, just above the radius of the track. Attach horizontal track to commercial flag bracket using two 1/4" x 5/8" [6 mm x 16 mm] track bolts and flange nuts. Attach extension angle to horizontal track using 3/8" x 1-1/4" [10 mm x 32 mm] slotted truss head bolt & nut. Attach extension angle to commercial flag bracket using a 3/8" x 3/4" [10 mm x 19 mm] carriage bolt & flange nut. Temporarily set back hangs for horizontal track or rig a temporary rope to support back of horizontal track.(Fig. 6-T)

Step 2: Top Section. Install top section now to other sections. Refer to "Preparing and Installing Door".

Step 3: Spring Installation. Install end bearing plates as shown. (Fig. 6-T) Refer to "Spring Installation" for additional instruction.

Step 4: Spring Winding. Refer to "Spring Winding" for instructions.

Step 5: Backhang Doors. After springs are installed and wound, release locking pliers and raise door so that only the two top sections are in the horizontal tracks. Secure door in place with locking pliers on vertical track above a roller, making sure it can't be raised, and align horizontal tracks. Backhang doors. Any door over 12' [366 cm] high requires a center hang and a backhang on each horizontal track. See "Backhang Requirements" for backhang requirements. All backhang material is supplied by the installer.

Step 6: Final Adjustment. Refer to "Final Adjustment and Maintenance" for instructions.

Low Headroom Double Track (LHR)

Step 1: Horizontal track install. Attach horizontal track to commercial flag bracket using two 1/4" x 5/8" [6 mm x 16 mm] track bolts and flange nuts. Attach horizontal angle to commercial flag bracket using a 3/8" x 3/4" [10 mm x 19mm] carriage bolt and flange nut. (Fig. 7-T) Temporarily set back hangs for horizontal track or rig a temporary rope to support horizontal track.

Step 2: Top section. Install top section now to other sections. Refer to "Preparing & Installing Door Sections".

Step 3: Spring Installation. LHR doors can be installed w/ either rear torsion springs (springs at the back of the horizontal track) or in the standard front mount position. Front mount is easier, but requires more headroom & door may hang in the opening unless an electric operator is used. Refer to "Spring Installation" for instructions.

Step 4: Spring Winding. Refer to "Spring Winding" for instructions.

Step 5: Backhang Doors. Unless backhangs are installed during spring installation (typical for rear mount springs), release locking pliers and raise door so that only the two

top sections are in the horizontal tracks. Secure door in place with locking pliers on vertical track above a roller, making sure it can't be raised, and align horizontal tracks. Backhang doors. Any door over 12' [366 cm] high requires a center hang and a backhang on each horizontal track. See "Backhang Requirements" for backhang requirements. All backhang material is supplied by the installer.

Step 6: Final Adjustment. Refer to "Final Adjustment and Maintenance" for instructions.

If a spring bumper is required refer to Fig. 11-T.

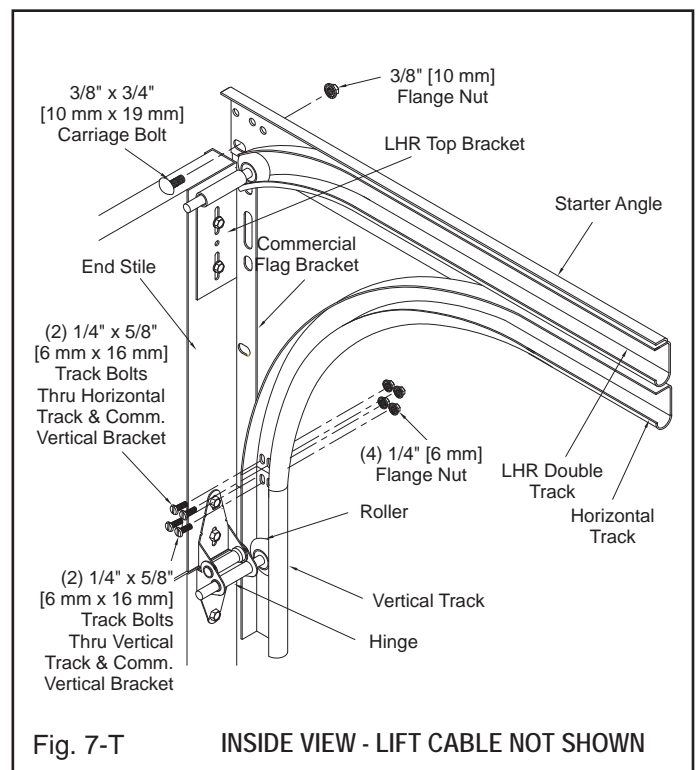
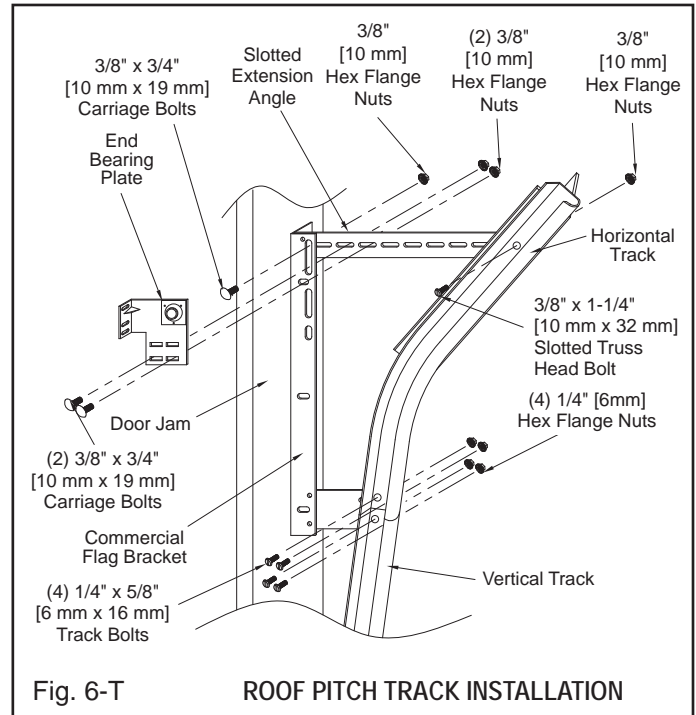

Vertical Lift Track

Step 1: Vertical Track Install. Vertical lift tracks are built as one piece or as two pieces per side, depending on door height.

Follow the vertical track installation instructions for the lower part of the track, from floor to the top of the door.

Step 2: Upper vertical track install. Starting at the top of the door, plumb upper vertical tracks to lower vertical tracks. Attach upper track to lower track using 1/4" x 5/8" [6 mm x 16 mm] track bolts. Attach to jamb with lags/screws in the mounting angles. Temporarily set sway braces for upper track. (Fig. 8-T)

Step 2: Top Section. Install top section now to other sections. Refer to "Preparing and Installing Door".

Step 3: Spring Installation. Install end bearing plates as shown. (Fig. 8-T) Refer to "Spring Installation" for additional instruction.

Step 4: Spring Winding. Refer to "Spring Winding" for instructions.

Step 5: Sway Brace Doors. After springs are installed and wound, release locking pliers and raise door **so that only the two top sections** are in the upper tracks. Secure door in place with locking pliers on vertical track above a roller, making sure it can't be raised, and align upper track tracks. Sway brace doors. All sway brace material is supplied by the installer.

⚠ WARNING

Door may fall out of track if the track is improperly aligned.

Step 6: Final Adjustment. Attach spring bumpers. (Fig. 9-T) Position bumpers so that door clears opening and the top of the door rests against the bumpers. Drill in place. Use 5/16" x 1" [8 mm x 25 mm] hex head bolts to fasten to track. Refer to "Final Adjustment and Maintenance" for additional instructions.

⚠ WARNING

Door may come out of track if spring bumper is not installed.

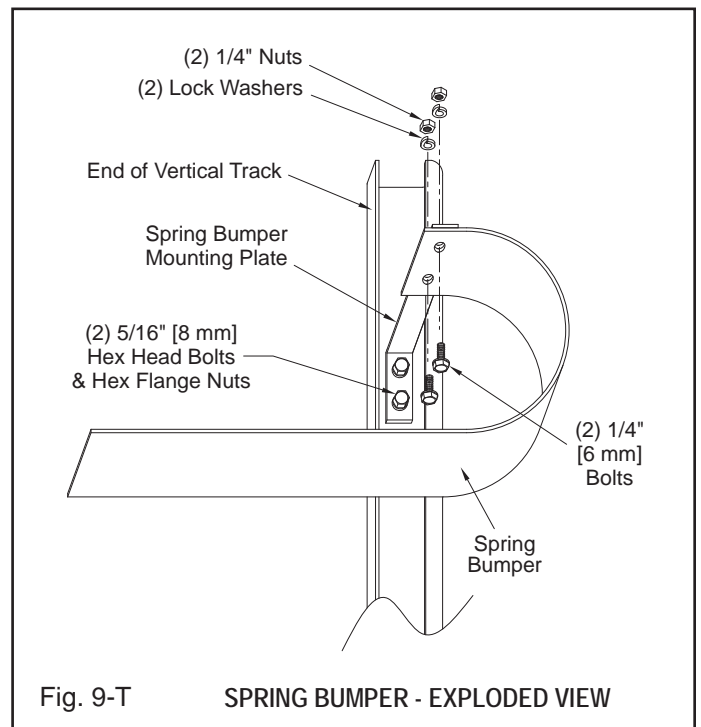
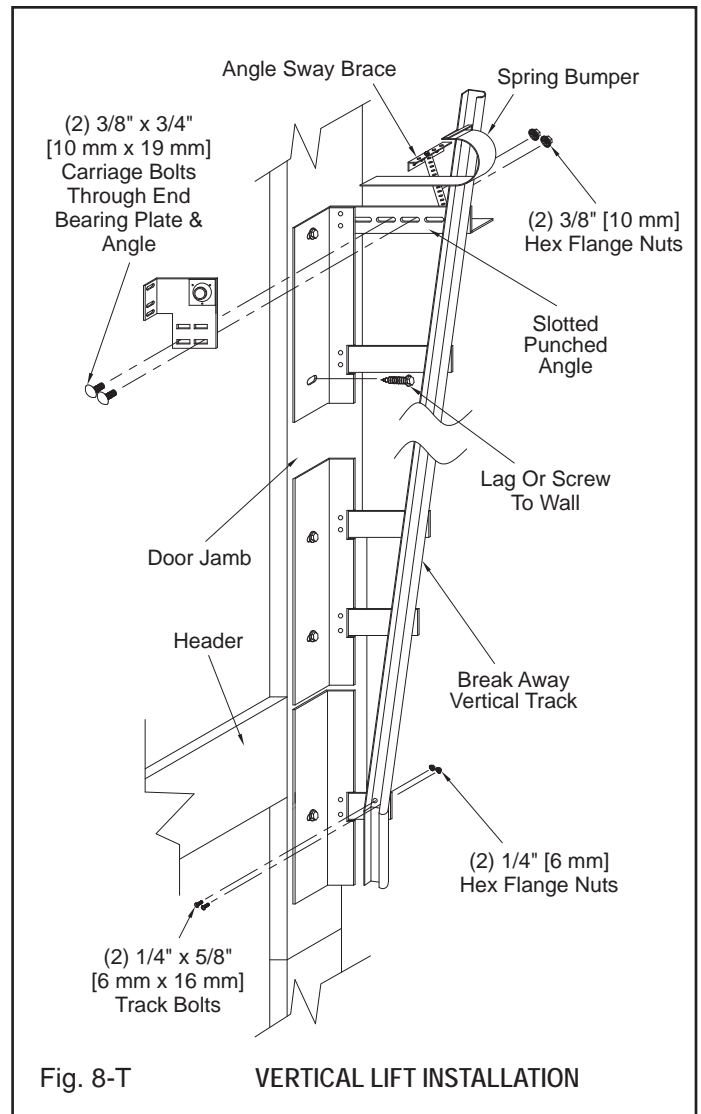

High Lift Track

Step 1: Lower vertical track. Some doors with smaller amounts of high lift will come with vertical tracks in one piece plus the horizontal tracks. Larger high lift doors will have the vertical track in two pieces plus the horizontals.

Follow the vertical track installation instructions for the lower part of the track, from floor to the top of the door.

Step 2: Upper vertical track. Starting at the top of the lower track, plumb upper vertical tracks to lower vertical tracks. Attach upper track to lower track using 1/4" x 5/8" [6 mm x 16 mm] track bolts. Attach to jamb with lags/screws in the mounting angles.

Step 3: Horizontal Track. Attach horizontal track to vertical angle using two 1/4" x 5/8" [6 mm x 16 mm] track bolts & flange nuts. Attach extension plate to horizontal angle then attach to vertical angle using 3/8" x 3/4" [10 mm x 19 mm] carriage bolts & flange nuts. (Fig. 10-T) Temporarily set back hangs for horizontal track or rig a temporary rope to support back of horizontal track.

Step 4: Top Section. Install top section now to other sections. Refer to "Preparing and Installing Door".

Step 5: Spring Installation. Install end bearing plates as shown. (Fig. 10-T) Refer to "Spring Installation" for additional instruction.

Step 6: Spring Winding. Refer to "Spring Winding" for instructions.

Step 7: Backhang Doors. After springs are installed and wound, release locking pliers and raise door **so that only the two top sections** are in the horizontal tracks. Secure door in place with locking pliers on vertical track above a roller, making sure it can't be raised, and align horizontal tracks. Backhang doors. **Any horizontal track over 11'-6" [350 cm] high requires a center hang and a backhang on each horizontal track.** See "Backhang Requirements" for backhang requirements. All backhang material is supplied by the installer.

Step 8: Final Adjustment. Attach spring bumpers. (Fig. 11-T) Position bumpers so that door clears opening and the top of the door rests against the bumpers. Drill in place. Use 5/16" x 1" [8 mm x 25 mm] hex head bolts to fasten to track. Refer to "Final Adjustment and Maintenance" for additional instructions.

WARNING

Door may come out of track if spring bumper is not installed.

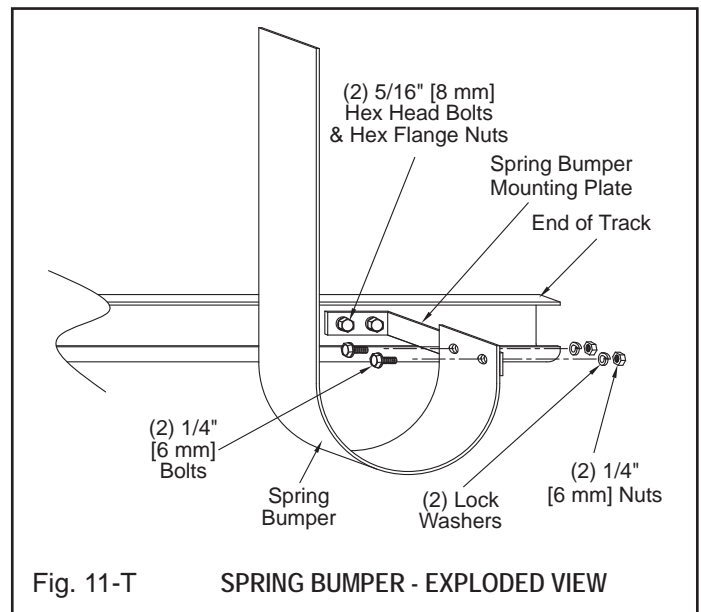
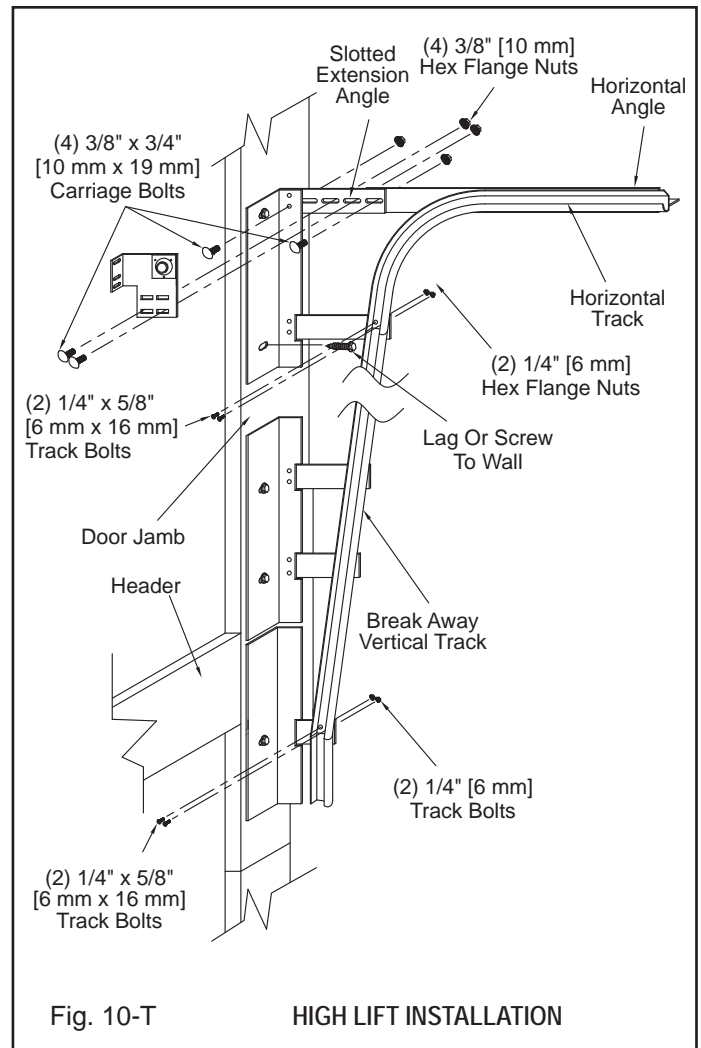

Spring Installation

NOTE: All torsion spring doors will be furnished with a Red Warning Label. These labels must be on all spring anchor brackets in plain view. These Warning Labels will be supplied on spring anchor brackets or in the hardware carton. If label is missing it is the responsibility of the installer to contact their supplier and have them provide needed warning labels for installation.

Step 1: Spring anchor bracket mounting location. Measure from top of door to center of the end bearings. Draw a straight horizontal line across the header at this height for shaft location and mount spring anchor bracket(s) accordingly. Spring anchor bracket quantity & mounting location(s) are determined by number of springs and door width. Spring anchor brackets require a min 6" [152 mm] from shaft coupler, and a min. 3" [76 mm] from cable drums and other spring assemblies. Refer to Fig. 1-TOR, 2-TOR & 3-TOR for typical arrangements. Determine spring anchor bracket locations & attach an anchor pad at each location.

Step 2: Tube/Shaft Installation. Torsion spring doors require either a or solid steel shaft. See below for specific process for each.

Torsion Tube Installation

Loosen all set screws on springs and drums. Slide springs, shaft bearing and drums on tube. Slide tube into one end bearing plate then back through the opposite one Center tube. **Fasten spring anchor bracket to anchor pad using 5/16" x 1-5/8" [8 mm x 41 mm] red colored lag screws (wood) or 5/16" x 1" [8 mm x 25 mm] red colored self-tapping screws (steel).** Slide shaft bearing into the stationary cone on spring. Slide spring against spring anchor bracket and attach using (2) 3/8" [10 mm] cap screw & bolt. See warning below. Tube must be straight and level. (Fig. 1-TOR)

NOTE: Pilot drill in wood with 3/16" [5 mm] drill.

⚠ WARNING

Spring anchor brackets anchor the springs to the wall. You must fasten securely with red-colored fasteners. Never remove spring anchor bracket when springs are wound.

Slide drums against end bearing plates and tighten set screws on one of the drums.

Set screws: Tighten set screws enough to dimple shaft, about 1-1/4 turns after set screws first hit shaft.

Bring cable up between wall and roller shafts behind drum and into notch in edge of drum. Turn drum and shaft until cable is taught. Make sure cable stop is seated against drum. Clamp locking pliers on shaft and against header to hold cable taught. Wind cable on other drum, rotate drum until cable is taught and tighten set screws. Tension must be equal on both cables. Cables are now set. See "Spring Winding".

Solid Shaft Installation

Loosen all set screws on springs and drums. Slide springs, shaft bearing and drums on shaft. Install half of shaft coupler. Insert key and tighten set screw.

Set screws: Do not exceed 1/2 turn after coming in contact with shaft.

Slide either shaft half into end bearing and **fasten spring anchor bracket to anchor pad using 5/16" x 1-5/8" [8 mm x 41 mm] red colored lag screws (wood) or 5/16" x 1" [8 mm x 25 mm] red colored self-tapping screws (steel).** Center shaft, slide other shaft into opposite side and align shaft coupler. Attach shaft couplers together loosely with coupler bolts and fasten spring anchor brackets. Slide shaft bearing into the stationary cone on spring. Slide spring against spring anchor bracket and attach using (2) 3/8" x 1-1/2" [10 mm x 38 mm] cap screw & bolt. Slide both drums against end bearings and insert 1/4" x 1/4" [6 mm x 6 mm] keys and then tighten set screws. (Fig. 2-TOR)

Bring cable up between wall and roller shafts, behind drum and into notch in edge of drum. Turn drum and shaft until cable is tight. Make sure cable stop is seated against drum.

Clamp locking pliers onto shaft and against header to hold cable tight. Repeat procedure for setting cable on the opposite side. Tension must be equal on both cables. Tighten coupler bolts. Cables are now set. See "Spring Winding".

Auxiliary Shaft Supports (If Required)

Refer to Fig. 1-AT for placement of auxiliary shaft supports, if required. Auxiliary bearings must be assembled to the shaft before drums are put on shaft.

*Used on 20', [610 cm] or wider doors or doors 730 lbs. [331 kg] or greater. To be installed approximately 3" in from drum.

**Used only on doors over 20' [610 cm] wide with only two springs. Auxiliary support bearing is to be installed halfway between spring and drum.

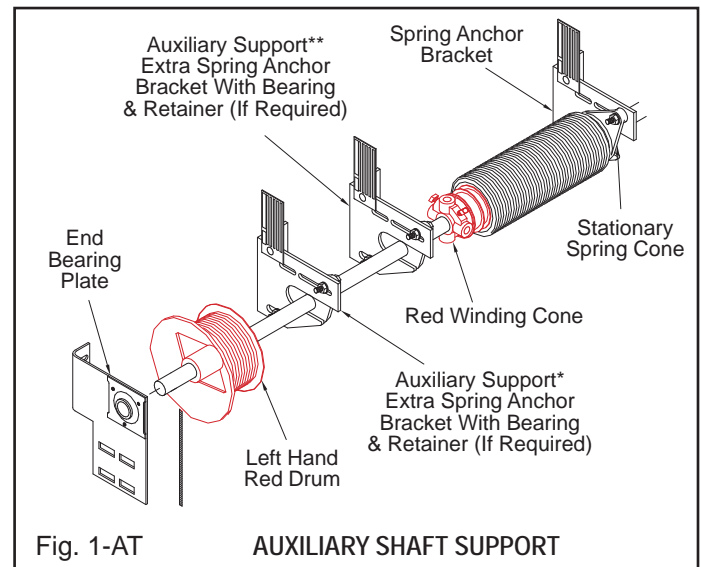

For Torsion Springs Only

WARNING

Each spring anchor bracket requires a wood/steel anchor pad. You must make sure that the wood or steel anchor pad is of good quality, free of cracks or splits.

IMPORTANT: The wood anchor pad must be made of a Grade 2 or better Southern Yellow Pine (also known as Southern Pine or Yellow Pine) 2" x 6" x 12" [51 mm x 152 mm x 305 mm] minimum. The Southern Yellow Pine must be free of splits and cracks. Do not use wood labeled as spruce-pine-fir (or SPF). Steel anchor pads should be 1/4" x 10" x 12" [6 mm x 254 mm x 305 mm] minimum, securely fastened to the structure.

The wood/steel anchor pad must be installed into the structural frame of the building, not the drywall or sheet rock. Use at least (4) 3/8" x 3" [10 mm x 76 mm] long lag screws for wood structures or 3/8" [10 mm] masonry anchors for concrete/block structures (one at each corner). Do not install lag screws/masonry anchors less than 1-1/2" [38 mm] from the sides or ends of the anchor pad. Under no circumstances should the anchor pad be attached with nails. Anchor pad and hardware are not supplied.

Rear Mount Torsion Spring

LHR doors can be installed with rear torsion springs up to a maximum door weight of 800 lbs. [363 kg]. Greater than that, the door must be installed with front torsion springs, up to 1,400 lbs.

Step 1: End Bearing plates. The end bearing plate will be positioned and fastened to the back end of the horizontal track. (Fig. 2-AT) Some drilling in the end bearing plate & horizontal angle may be required.

Step 2: Pulley install. For doors under 350 pounds [159 kg], install the 4" [102 mm] pulley as illustrated in Fig. 2-AT. For doors over 350 pounds [159 kg], install the 5" [127 mm] pulley and saddle as illustrated in Fig. 2-AT, Detail "E". The truss head 3/8" bolts used must be installed with the heads toward the inside of the track and the nuts facing outside as in the illustration. The cable must be routed through the pulley saddle prior to attaching to drum.

Step 3: Backhang doors. Before springs are installed and wound, align horizontal track. Attach backhangs. **Any door over 12' [366 cm] high requires a center hang and a backhang on each horizontal track.** See "Backhang Requirements" for backhang requirements. All backhang material is supplied by the installer.

Step 4: Spring Install. Rear torsion springs doors will require that springs be placed at rear of track and a center support hanger(s) be provided that is strong enough to withstand the torque of the springs. Install springs and wind (Fig. 2-AT), refer to "Spring Winding" for additional instruction.

LHR Front Mount Torsion Springs

Step 1: End Bearing plates. Attach the end bearing plate as shown. (Fig. 3-AT) Some drilling in the end bearing plate & horizontal angle may be required.

Install springs and wind. (Fig. 4-AT) Refer to "Spring Winding" for additional instruction.

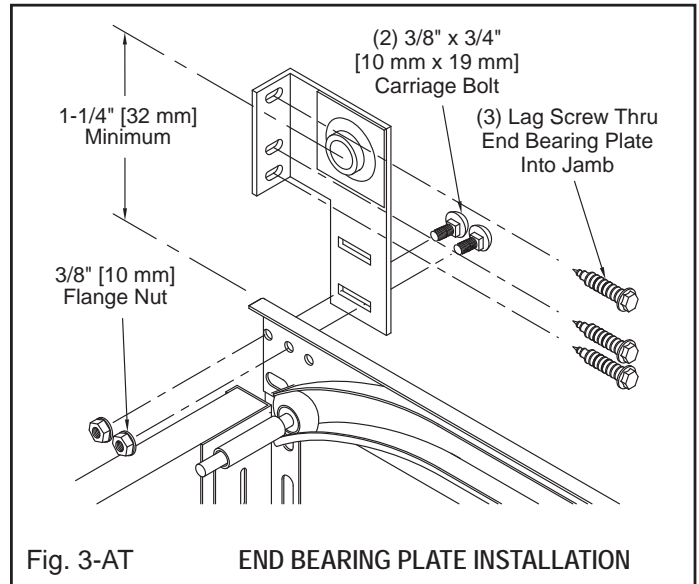

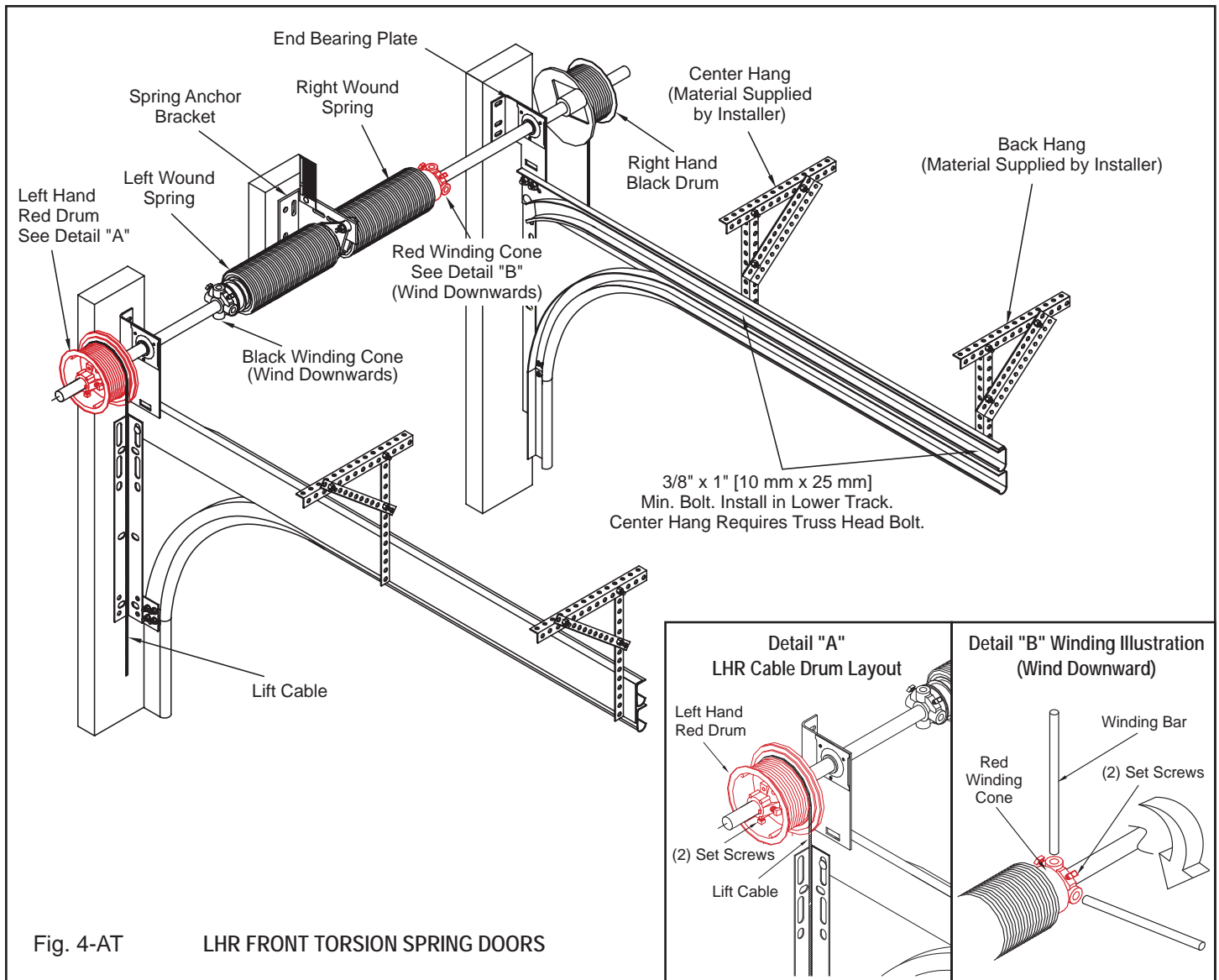

Spring Winding

⚠ WARNING

SPRING TENSION IS DANGEROUS. A sudden release of the springs could result in severe injury. Proceed with caution, following these instructions carefully. Before winding any tension on springs, make sure door is securely locked down with a vise-grip placed on vertical track above a roller. Always use proper size winding bars. Never use screwdrivers or any tool too large or too small. They may break and cause serious injury. Stand to the side of winding bars while winding springs.

Step 1: Wind springs. Draw a straight chalk line across spring. This will indicate the number of turns on spring as you wind. As spring is wound, the line will appear to wrap around the spring. By counting the number of wraps minus 1 will equal the number of turns that have been completed. Springs will get longer when wound. Using two cold rolled

steel winding bars about 18" [457 mm] long (not supplied) that fit snugly in the winding plug holes, wind the springs toward ceiling as shown. (Fig. 1-TOR, 2-TOR & 3-TOR) Fig. 1-TOR, 2-TOR & 3-TOR are generic examples and may not necessarily match the required spring arrangement for your door. Low headroom double track doors: wind springs toward the floor (down) instead of up. Wind springs the number of turns shown on the hardware box label.

⚠ WARNING

At this point, springs are fully wound. Springs should stretch easily. Do not force, as it could break the winding plug and cause injury

Step 2: Set Screws. The set screw depends on type of tube/shaft used. See below.

Torque Tube: Tighten set screws enough to dimple shaft, about 1-1/4 turns after set screws first hit shaft.

Solid Shaft: Do not exceed 1/2 turn after coming in contact with shaft.

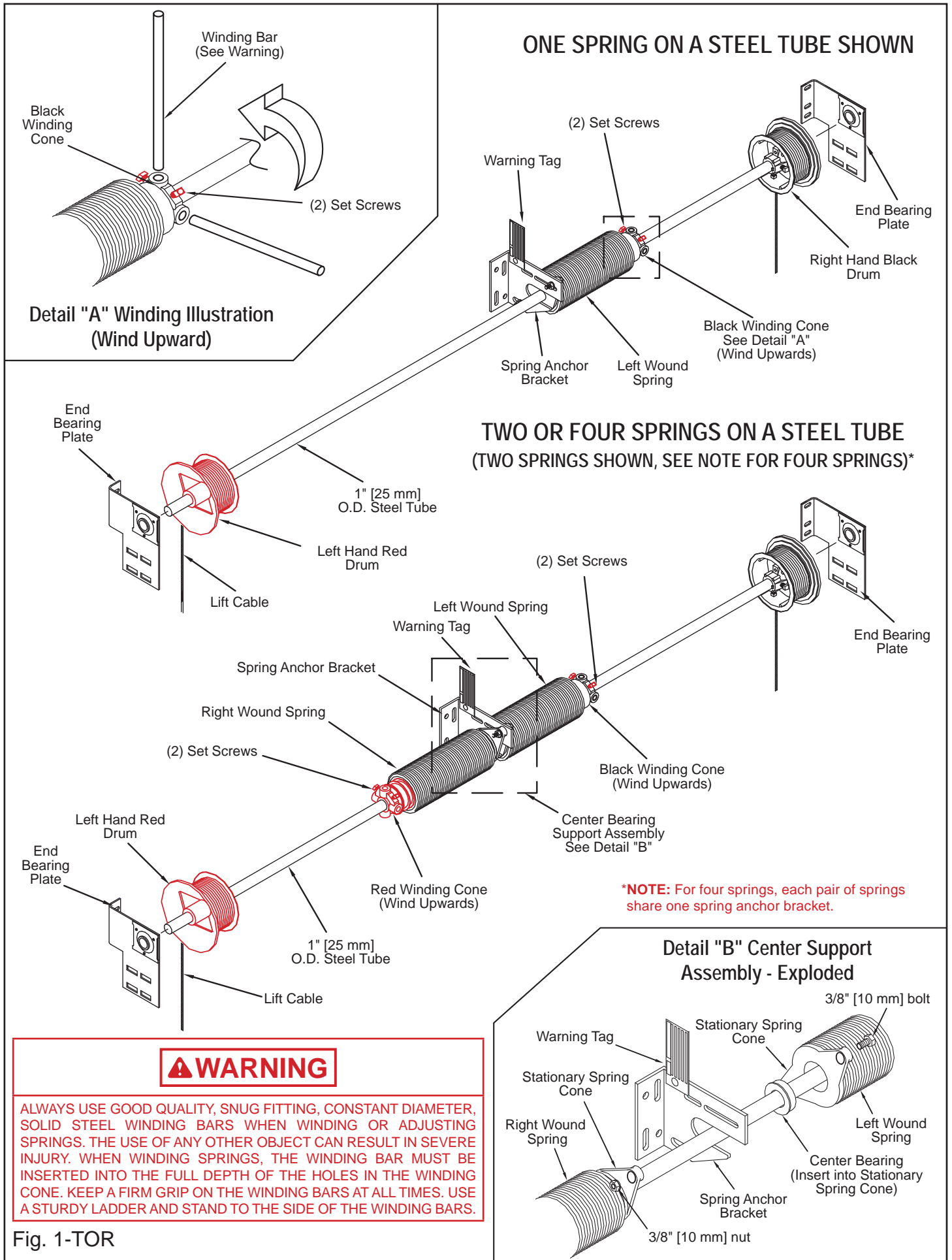

⚠ WARNING

ALWAYS USE GOOD QUALITY, SNUG FITTING, CONSTANT DIAMETER, SOLID STEEL WINDING BARS WHEN WINDING OR ADJUSTING SPRINGS. THE USE OF ANY OTHER OBJECT CAN RESULT IN SEVERE INJURY. WHEN WINDING SPRINGS, THE WINDING BAR MUST BE INSERTED INTO THE FULL DEPTH OF THE HOLES IN THE WINDING CONE. KEEP A FIRM GRIP ON THE WINDING BARS AT ALL TIMES. USE A STURDY LADDER AND STAND TO THE SIDE OF THE WINDING BARS.

Fig. 1-TOR

Detail "A" Right Hand Drum Attachment (Left Hand Drum Is Mirrored)

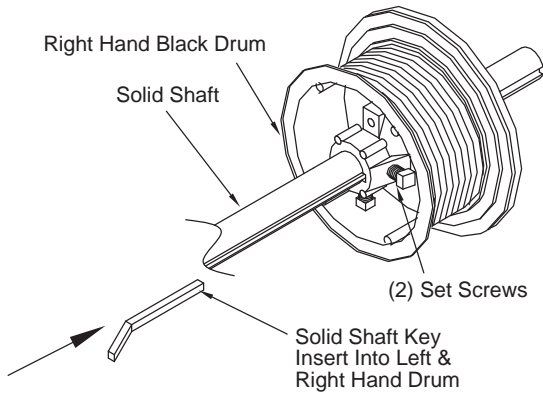

Detail "B" Winding Illustration (Wind Upward)

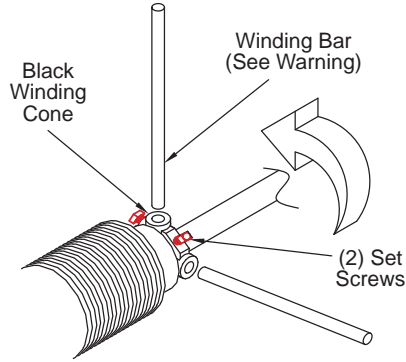

TWO SPRINGS ON A SOLID SHAFT SHOWN

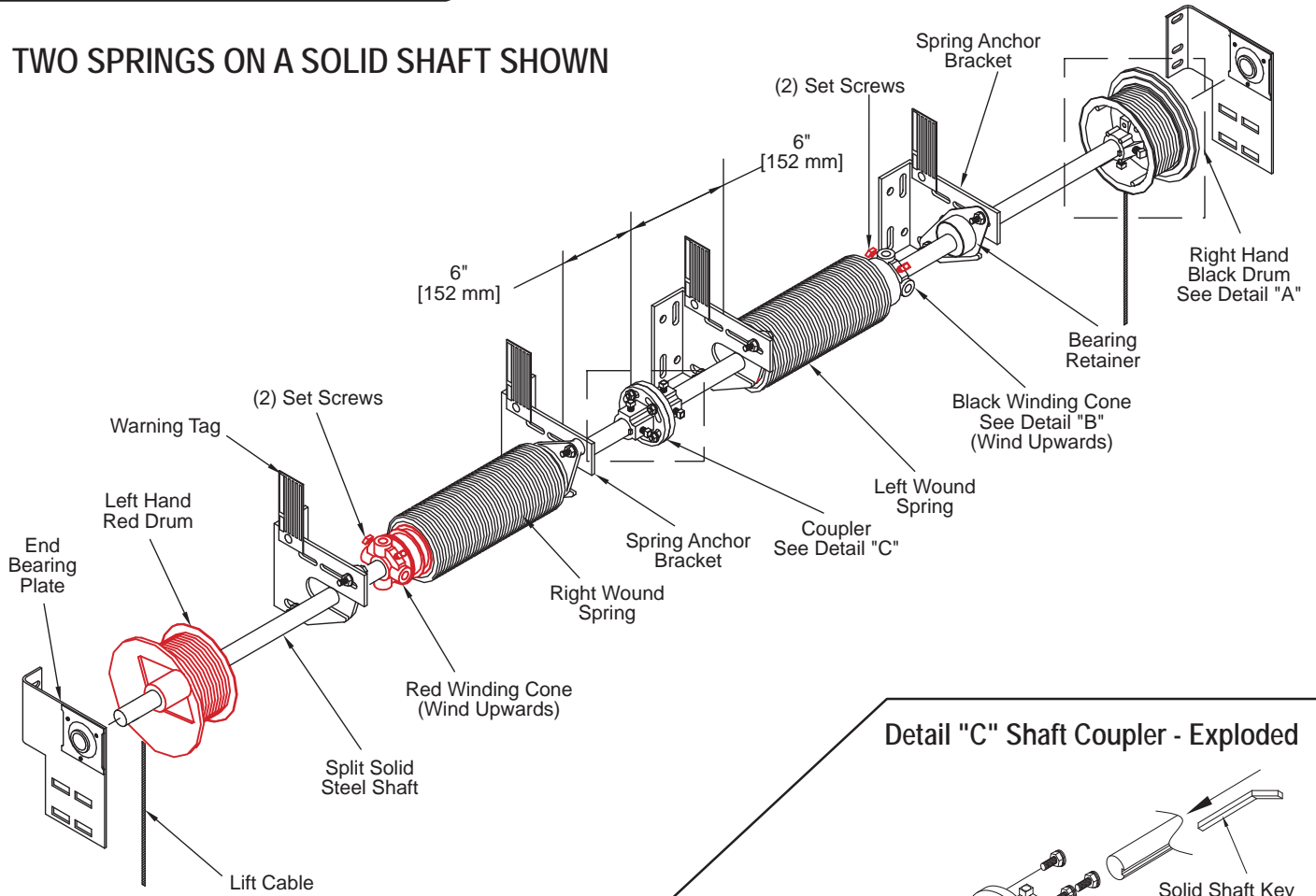

Detail "C" Shaft Coupler - Exploded

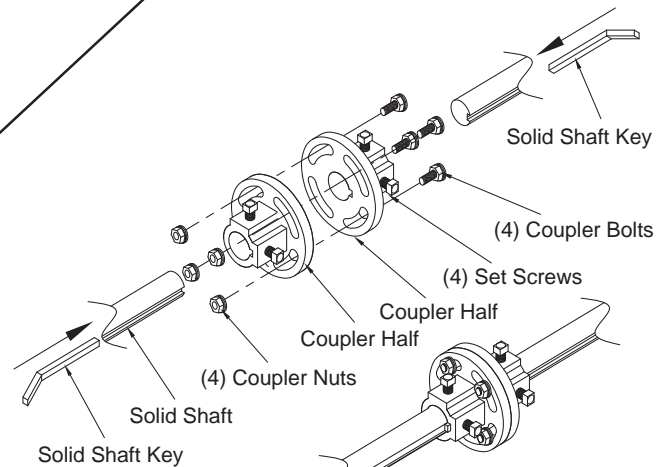

Shaft Coupler - Assembled

⚠ WARNING

ALWAYS USE GOOD QUALITY, SNUG FITTING, CONSTANT DIAMETER, SOLID STEEL WINDING BARS WHEN WINDING OR ADJUSTING SPRINGS. THE USE OF ANY OTHER OBJECT CAN RESULT IN SEVERE INJURY. WHEN WINDING SPRINGS, THE WINDING BAR MUST BE INSERTED INTO THE FULL DEPTH OF THE HOLES IN THE WINDING CONE. KEEP A FIRM GRIP ON THE WINDING BARS AT ALL TIMES. USE A STURDY LADDER AND STAND TO THE SIDE OF THE WINDING BARS.

Fig. 2-TOR

Detail "A" Supplemental Bearing Support Assembly - Exploded

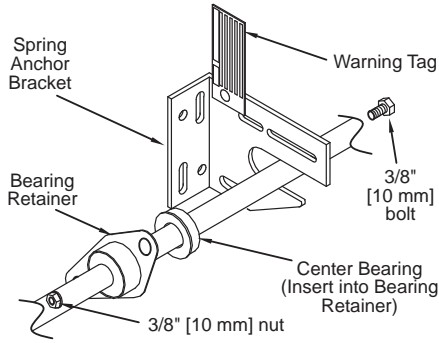

Detail "B" Center Support Assembly - Exploded

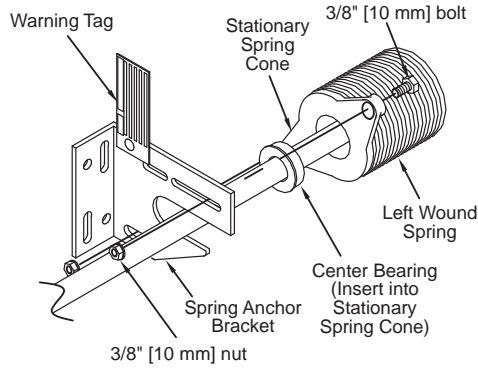

**FOUR SPRINGS ON A SOLID SHAFT SHOWN
(SEE NOTE)***

***NOTE:** 2" & 2-5/8" dia. springs can be mounted in the arrangement shown in Fig. 1-TOR.

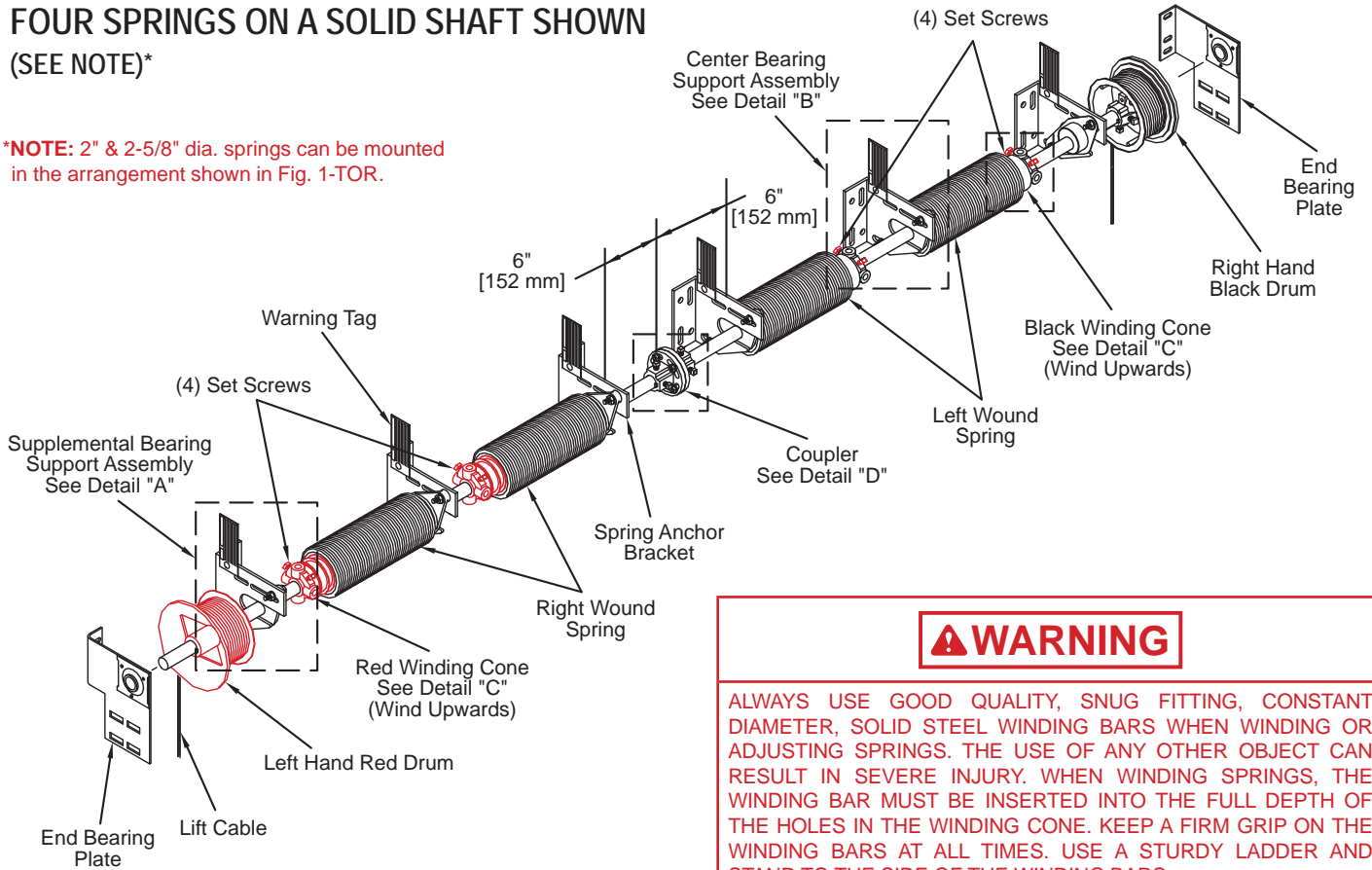

WARNING

ALWAYS USE GOOD QUALITY, SNUG FITTING, CONSTANT DIAMETER, SOLID STEEL WINDING BARS WHEN WINDING OR ADJUSTING SPRINGS. THE USE OF ANY OTHER OBJECT CAN RESULT IN SEVERE INJURY. WHEN WINDING SPRINGS, THE WINDING BAR MUST BE INSERTED INTO THE FULL DEPTH OF THE HOLES IN THE WINDING CONE. KEEP A FIRM GRIP ON THE WINDING BARS AT ALL TIMES. USE A STURDY LADDER AND STAND TO THE SIDE OF THE WINDING BARS.

Detail "C" Winding Illustration (Wind Upward)

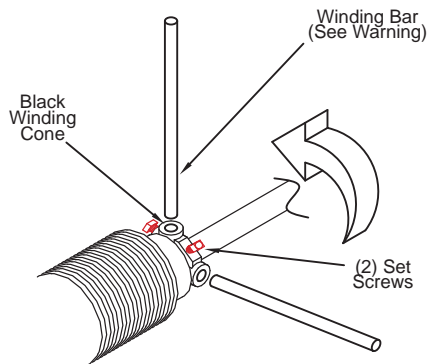

Detail "D" Shaft Coupler - Exploded

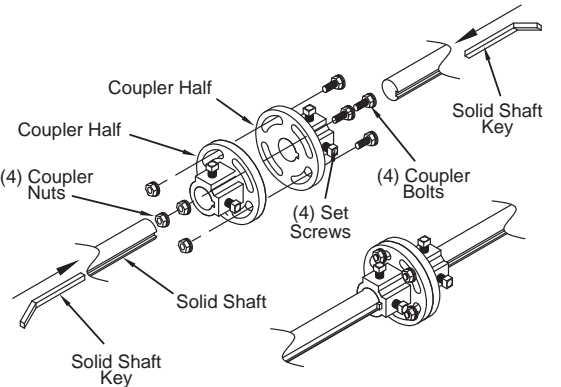

Shaft Coupler - Assembled

Fig. 3-TOR

Final Adjustment and Maintenance

Step 1: Final Adjustment. Lower door. Push track (if adjustable) towards jambs until door is tight against door stop/steel jambs. Tighten track bolts. Adjust top brackets. (For LHR Only: Move LHR top bracket upward in slots to seal top section against header. Tighten screws & secure end of top section strut, if required.) Nail door stop in place, if applicable. Lubricate all moving parts (hinges, rollers, bearings, springs, etc.) with light weight oil.

Step 2: Maintenance. Lubricate all moving parts about every six months. High use doors will require more frequent lubricating.

Every six months inspect your door for the following:

⚠ WARNING

Do not attempt to adjust door components unless you are a qualified door mechanic.

- Cables for fraying
- Torsion spring plugs and spring anchors
- Bearings in end bearing plates
- Rollers and hinges
- Track alignment
- Backhang angle and sway brace attachments
- Tighten all screws and nuts on bolts

Painting

Do not use any type of oil based paint or Alkyd modified acrylic latex paint. These paints will void the warranty of your door.

Cleaning: Before painting the door, it must be free of dirt, oils, chalk, waxes and mildew. It can be cleaned with a diluted solution of trisodium phosphate. Trisodium phosphate is available over the counter at most stores under the name SOILAX®, in many laundry detergents without fabric softener additives, and in some general purpose cleaners. Check the label for trisodium phosphate content. The recommended concentration is 1/3 cup [79 ml] of powder to 1-1/2 to 2 gallons [6 l to 8 l] of water. After washing the door, always rinse well with clear water and allow to dry.

If the door has ever been waxed, the wax must be removed before painting. Doors are not waxed during the manufacturing process. This can be accomplished by wiping the door surface with a rag saturated with Xylene (Xylol), available at most paint or hardware stores. Wiping should be done at moderate pressure and Xylene must not be allowed to sit on the door for an extended time. Damage to your door's paint system can occur if overexposed to this or other solvents.

Caution: Safety instructions on the solvent's container must be followed. After dewaxing the door, clean with trisodium phosphate, as stated previously.

NOTE: Sanding could remove rust-inhibiting compounds, therefore, sanding should be done only to damaged areas where bare metal has been exposed. Refer to the "Repair" section of these instructions.

Repair: Should your door's paint finish become damaged, exposing the bare metal, it will become necessary to repair this area to prevent rust from forming. The damaged area should be lightly sanded with a medium to fine sandpaper making sure to remove all visible red and white rust. Wipe this area with a dry, clean rag. Coat the sanded area with a high quality, rust inhibiting, zinc enriched primer. This type of primer can be found at most paint or hardware stores, and should be labeled for covering bare and galvanized steel. Once the primer is applied, wait the time specified on the primer's instructions before you finish painting your door.

Paint: Your steel garage door can be painted with a high-quality flat latex exterior grade paint. Since all paints are not created equal, the following test needs to be performed: paint should be applied on a small area of the door (following the instructions on the paint container), allowed to dry, and evaluated prior to painting the entire door. Paint defects to look for are blistering and peeling. An additional test is to apply a strip of masking tape over the painted area and peel back, checking to see that the paint adheres to the door and not to the tape.

After satisfactorily testing a paint, follow the directions on the container and apply to the door. Be sure to allow adequate drying time should you wish to apply a second coat.

With the exception of rubber gasket windows, window frames & inserts can be painted with a high quality latex paint. The plastic should first be lightly sanded to remove any surface gloss.

Window Replacement

⚠ WARNING

To avoid injury, use extreme caution in handling glass window pane. When the frame is removed, the exposed steel edge of the door may be sharp. Avoid contact with the steel edges.

If your door is equipped with windows and the glass should need replacement, follow the steps below:

1. With someone holding the outside frame, remove the screws from the inside window frame.
2. Pull the inside frame out of the door.
3. Carefully remove the broken or old glass.
4. Clean area where glass makes contact with the outside frame.
5. Apply caulk to area where glass makes contact with the outside frame.
6. Insert the new (replacement) glass.
7. With someone holding the outside frame, reinsert the screws into the inside frame, trapping the glass.

Attaching an Automatic Trolley Opener

WARNING

To avoid risk of strangulation or personal injury to children, you must remove the pull down rope when you install an automatic door operator.

NOTE: Failure to reinforce the door as illustrated will void the Manufacturers Warranty.

Doors with a stile at center of door:

- You will need three pieces of 14 gauge 2" x 2" [51 mm x 51 mm] punched angle iron. Two pieces should be 8 ft. [244 cm] long and one at least 24" [610 mm] long. The 24" [610 mm] piece may have to be trimmed to fit your door.
- Remove the fasteners from the top half of the three top section hinges closest to, or at, the center of the door. One 8 ft. [244 cm] piece of angle iron is to span across these three hinges and attached using fasteners previously removed.
- Place remaining 8 ft. [244 cm] piece across the top of the section, bridging across the same three stiles as the bottom angle. Attach with fasteners similar to ones used with the hinges. One fastener per stile. If your door has a strut at the top of the section, remove the bottom strut fasteners and overlap the flange of the strut with the angle iron to secure the bottom of the strut. Attach angle using the fasteners removed with the strut (Fig. 1-OP). Refer to Fig. 3-OP for C-Channel.
- Cut the 24" [610 mm] piece of punched angle iron to span from top horizontal angle to bottom horizontal angle. Place vertical angle directly above stile in the center of the door. Attach vertical angle through both the top and bottom horizontal angles to the stile beneath with fasteners similar to ones used with the hinges.

Doors without stile at center of door:

- You will need three pieces of 14 gauge 2" x 2" [51 mm x 51 mm] punched angle iron. Two pieces should be 4 ft. [122 cm] long and one at least 24" [610 mm] long. The 24" [610 mm] piece may have to be trimmed to fit your door.
- Remove the fasteners from the top half of the two top section bottom hinges closest to the center of the door. One 4 ft. [122 cm] piece of angle iron is to span across these two hinges and is attached using fasteners previously removed.
- Place remaining 4 ft. [122 cm] piece across the top of the section, bridging across the same two stiles as the bottom angle. Attach with fasteners similar to ones used with the hinges. One fastener per stile. If your door has a strut at the top of the section, remove the bottom strut fasteners and overlap the flange of the strut with the angle iron to secure the bottom of the strut. Attach angle using the fasteners removed with the strut. (Fig. 2-OP)

- Cut the 24" [610 mm] piece of punched angle iron to span from top horizontal angle to bottom horizontal angle. Place vertical angle directly in the center of the door. Attach vertical angle to both the top and bottom horizontal angles with two 3/8" [10 mm] nuts and two 3/8" [10 mm] bolts. Refer to Fig. 3-OP for C-Channel.

Attach the operator arm of garage door opener to the short vertical angle. The operator arm must be attached roughly at the same height as the top rollers of the door.

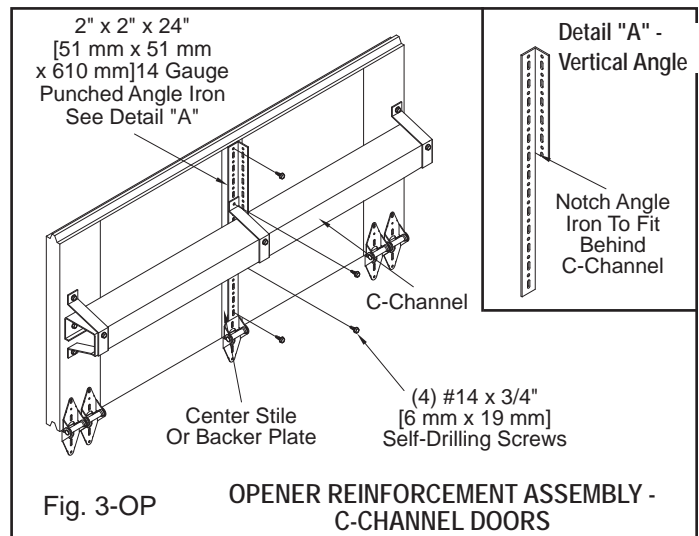
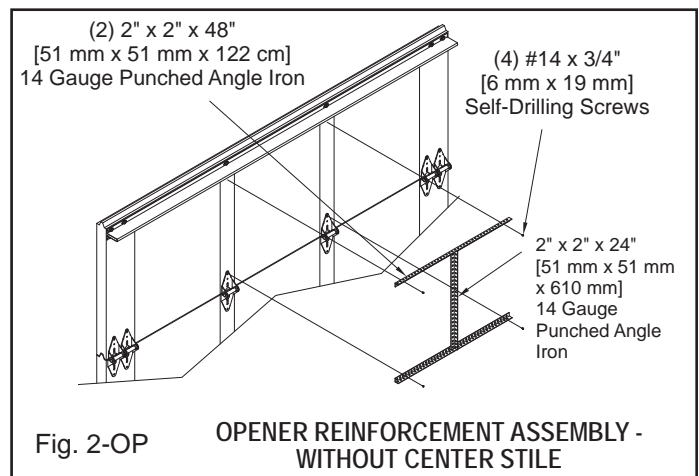
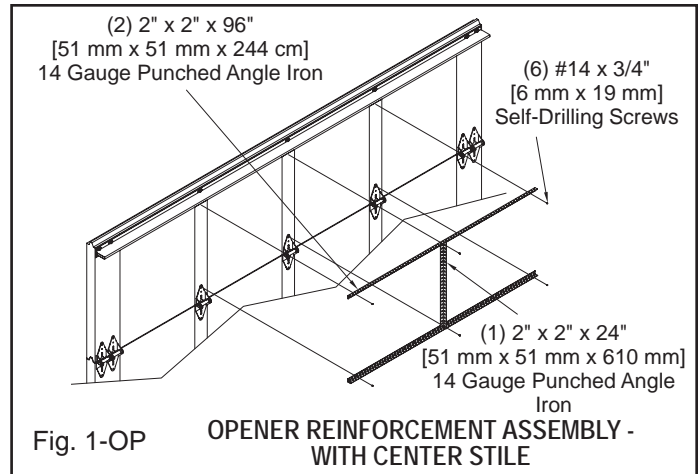

Special Components

Quick Turn Bracket

(Reduces headroom requirement by 2" [51 mm]. Quick turn bracket cannot be used in conjunction with any other low headroom option.) This is used in place of the existing top roller brackets.

1. Place two rollers in the tubes as shown. On some doors it will be necessary to try various roller positions to achieve the proper hinge location on the door. (Fig. 1-LHR)
2. Position the rollers and the bracket in the door track. Allow the hinged end of the bracket to come against the door. Apply sufficient pressure to be sure that the top of the door is closed tightly against the header.
3. Attach to the top of the door in the same manner as the original top roller bracket.
4. It may be necessary to relocate holes.

Heavy Duty Bearing Mounting System

Used for special applications. Follow instructions below for installation.

1. Attach heavy duty bearing to end bearing plate with (4) 3/8" [10 mm] bolt and nut - making sure that bolt head is toward cable drum. (Fig. 1-HDB)
2. Slide shaft into end bearing.
3. Slide spacer against end bearing then cable drum. Continue with spring installation process.

