



WHALEN®

LOT NUMBER: _____

DATE PURCHASED: __/__/__

Sheldon 48" Fireplace

Model # WSF48SH26C

WSF48SH26M

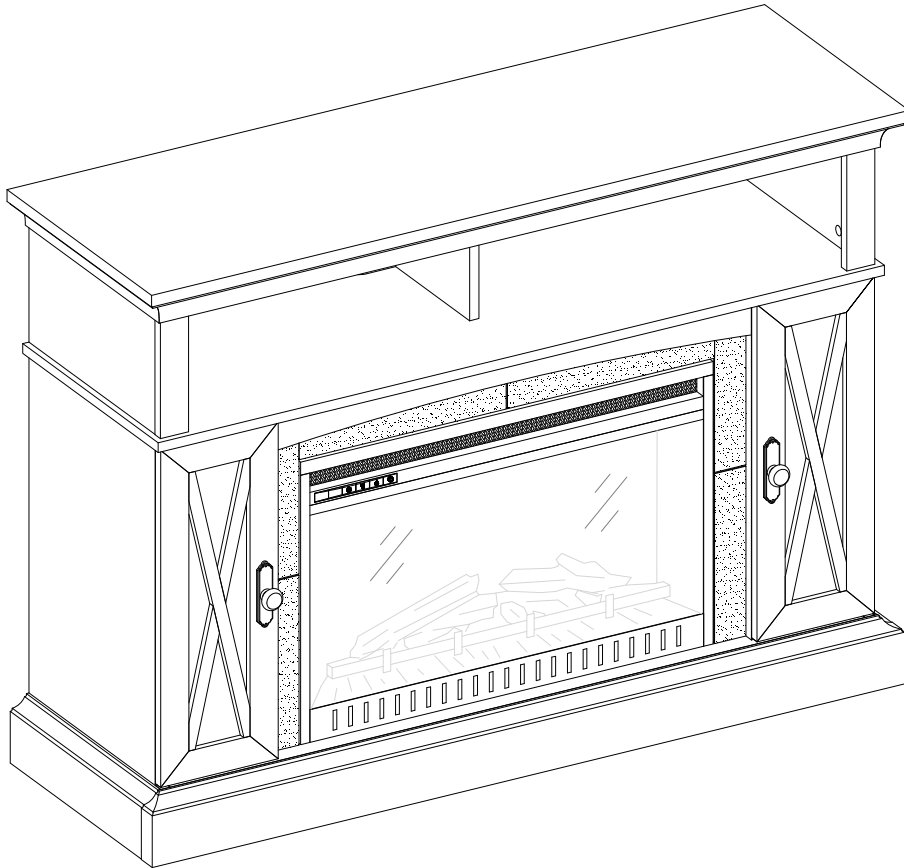

ADULT ASSEMBLY REQUIRED

If you have any questions regarding assembly or if parts are missing, DO NOT return this item to the store where it was purchased. Please call our toll-free customer service number and have your instructions and parts list ready to provide the model name, part name or factory number:

1-866-942-5362

Pacific Standard Time: 8:30 a.m. - 4:30 p.m., Monday - Friday

Or visit our website www.whalenfurniture.com

Or e-mail your request to: parts@whalenfurniture.com

**THIS INSTRUCTION BOOKLET CONTAINS IMPORTANT SAFETY INFORMATION.
PLEASE READ AND KEEP FOR FUTURE REFERENCE.**

QUALITY GUARANTEE

We are confident that you will be delighted with your Whalen Furniture purchase.

Should this product be defective in workmanship or materials or fail under normal use, we will repair or replace it for up to one (1) year from date of purchase. Every Whalen Furniture product is designed to meet your highest expectations. We guarantee that you will immediately see the value of our fine furniture.

This warranty gives you specific legal rights and you may also have other rights which vary from State to State.

Customer Service: 1-866-942-5362
8:30 a.m. - 4:30 p.m., PST, Monday to Friday
www.whalenfurniture.com

MAXIMUM RECOMMENDED WEIGHT LOADS

MANUFACTURER: Whalen Furniture Manufacturing
CATALOG: Sheldon 48" Fireplace
DATE OF MANUFACTURE: May 2015
MADE IN CHINA

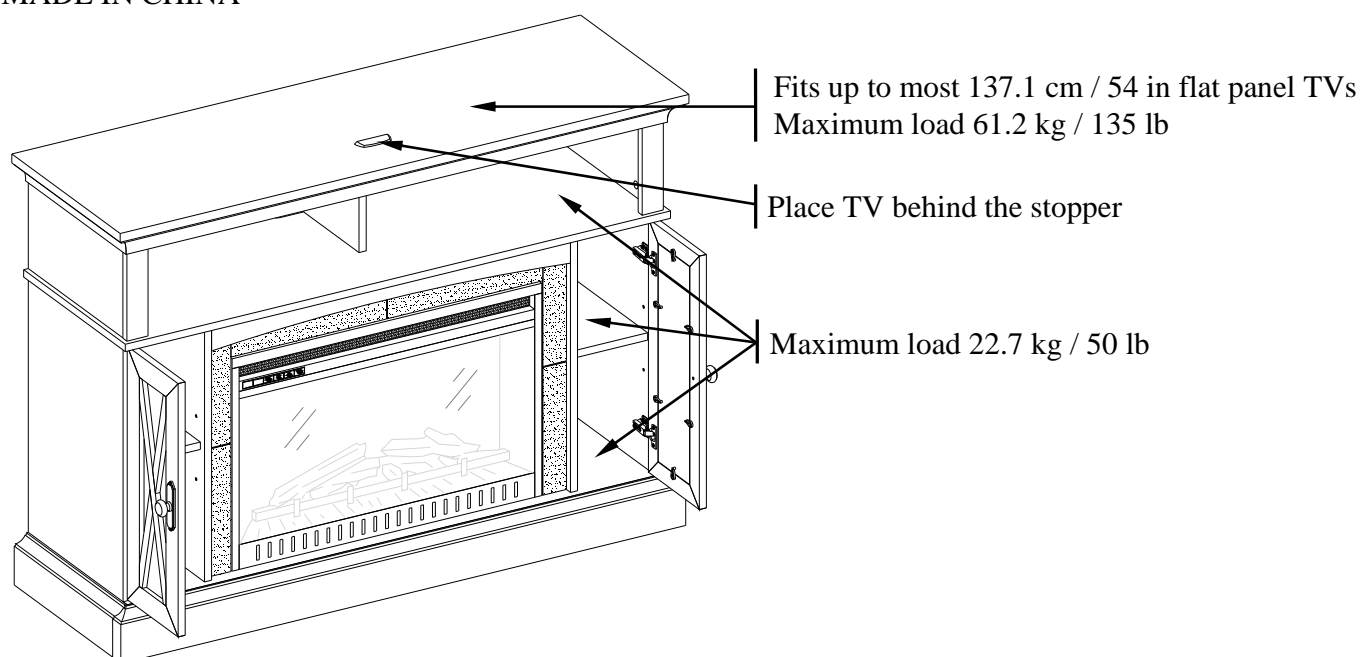

WARNING

THIS UNIT IS NOT INTENDED FOR USE WITH CRT TVS. USE ONLY WITH FLAT PANEL TVS AND AUDIO/VIDEO EQUIPMENT MEETING RECOMMENDED SIZE AND WEIGHT LIMITS. NEVER USE WITH LARGER/HEAVIER THAN RECOMMENDED FLAT PANEL TVS OR EQUIPMENT. TO AVOID INSTABILITY, PLACE FLAT PANEL TV IN THE CENTRE OF THE UNIT; THE BASE OF THE TELEVISION MUST BE ABLE TO REST ON THE SUPPORTING SURFACE OF THE UNIT WITHOUT OVER-HANGING THE EDGES. IMPROPERLY POSITIONED FLAT PANEL TVS, OR FLAT PANEL TVS OR OTHER EQUIPMENT THAT EXCEED RECOMMENDED SIZE AND WEIGHT LIMITS COULD FALL OFF OR BREAK THE UNIT, CAUSING POSSIBLE SERIOUS INJURY.

Please call for replacement parts or assistance: **1-866-942-5362**

Important

Before you begin: Open, identify and count all parts prior to assembly. Lay out parts on a flat and non-abrasive surface. You will need the parts identified on page 4 and 5 of this instruction manual.

NOTE: IT IS VERY IMPORTANT TO USE GLUE WITH THE DOWELS. EXCESS GLUE CAN BE WIPED OFF WITH A DAMP CLOTH.

Insert Dowel at least half way by tapping lightly with a rubber mallet (not included), IF NECESSARY.

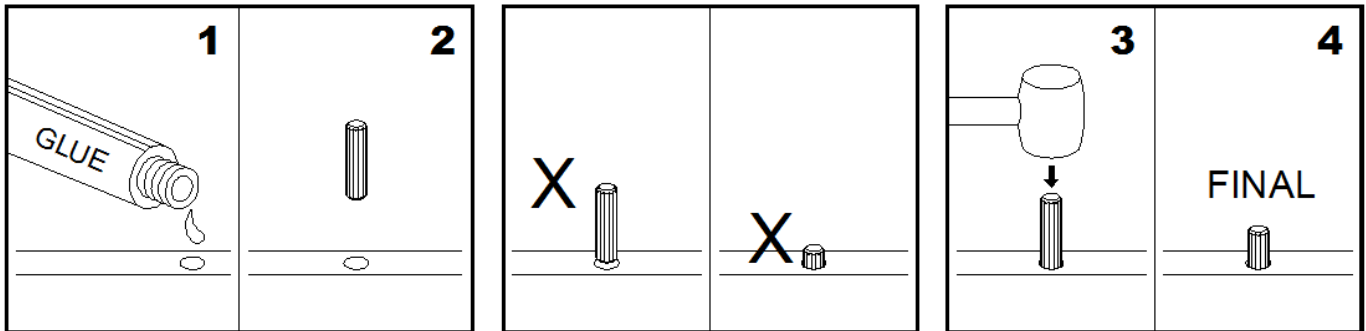

CAM LOCK SYSTEM OPERATION

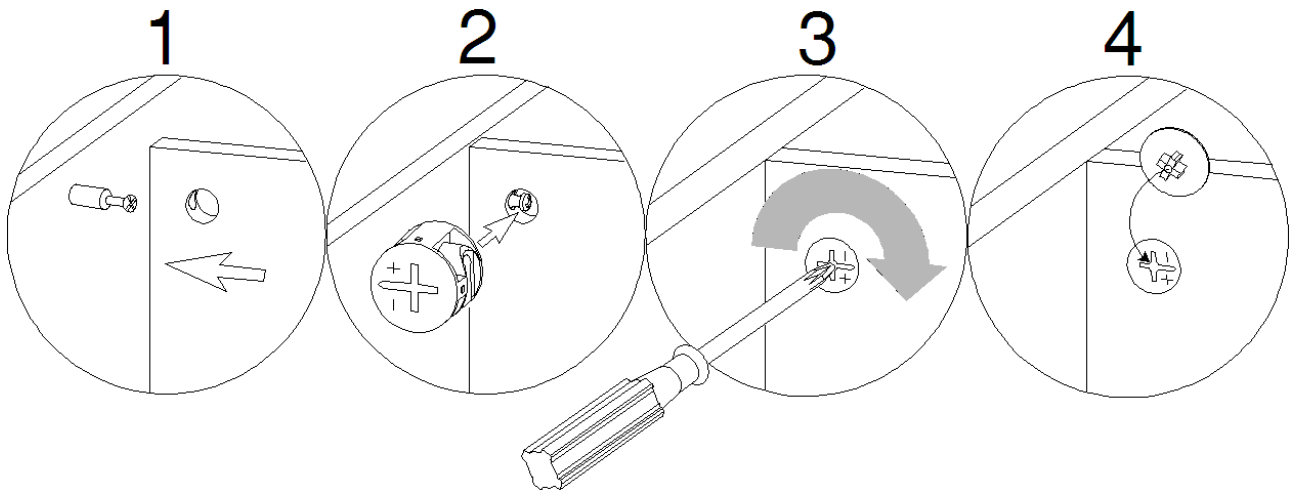

HOW THE KNOCK DOWN (KD) ASSEMBLY SYSTEM WORKS

1. Screw the Cam Bolt into the pre-drilled small holes on the panel. Connect both panels together; making sure the Cam Bolt goes into the pre-drilled hole at the end of the panel with the Cam Lock.
2. Insert the Cam Lock into the pre-drilled large hole in the panel. Make sure the arrow on the Cam Lock is pointed towards the Cam Bolt.
3. Once the Cam Bolt is connected inside the Cam Lock, take a Phillips screwdriver (not included) and tighten the Cam Lock clockwise.
4. Plug the Cam Lock Cover into the cross slot of the Cam Locks to conceal the cam.

You are now ready to assemble the KD unit.

Please call for replacement parts or assistance: **1-866-942-5362**

Parts and Hardware List

Please read completely through the instructions and verify that all listed parts and hardware are present before beginning assembly.

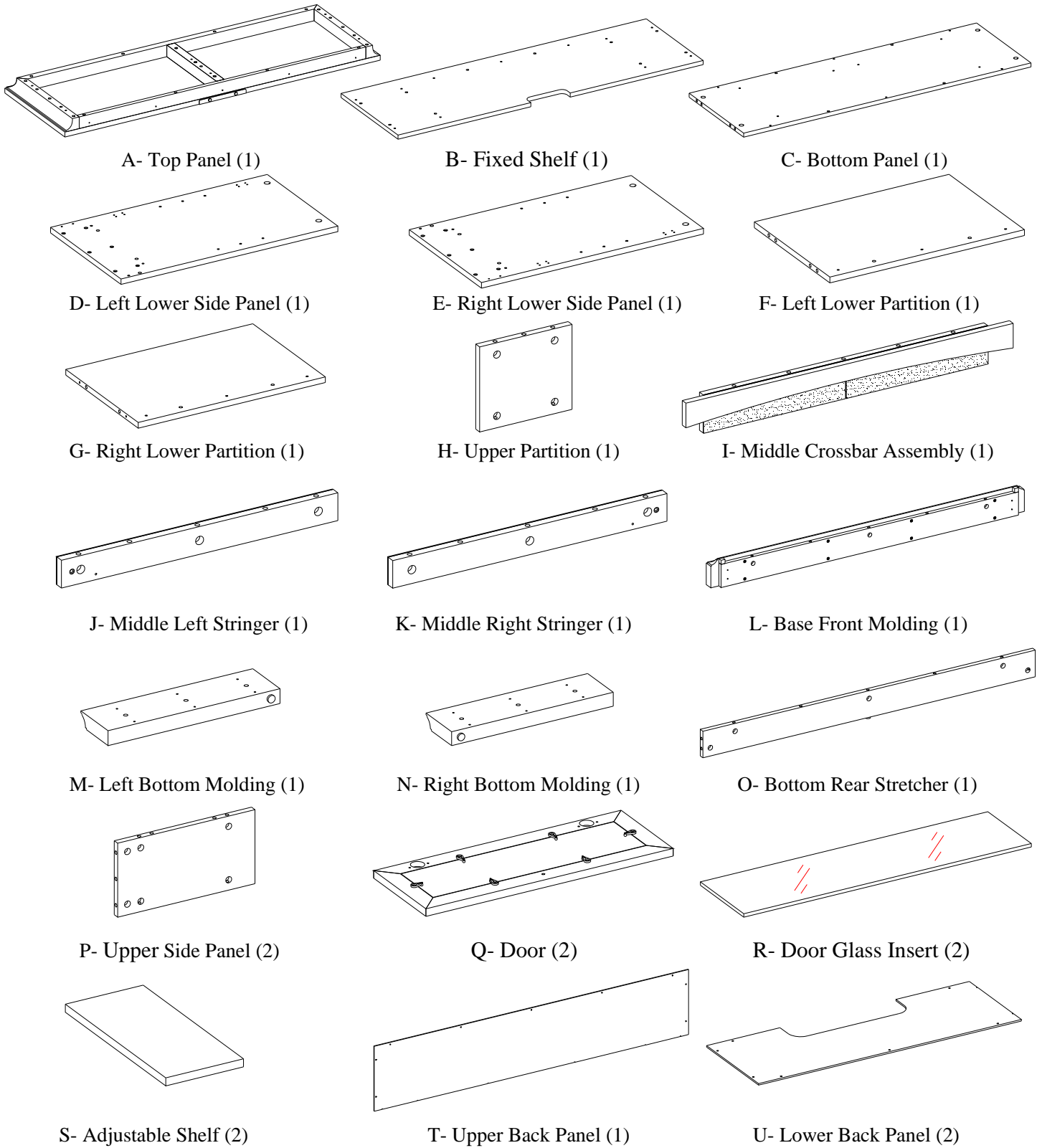

Parts and Hardware List

Please read completely through the instructions and verify that all listed parts and hardware are present before beginning assembly.

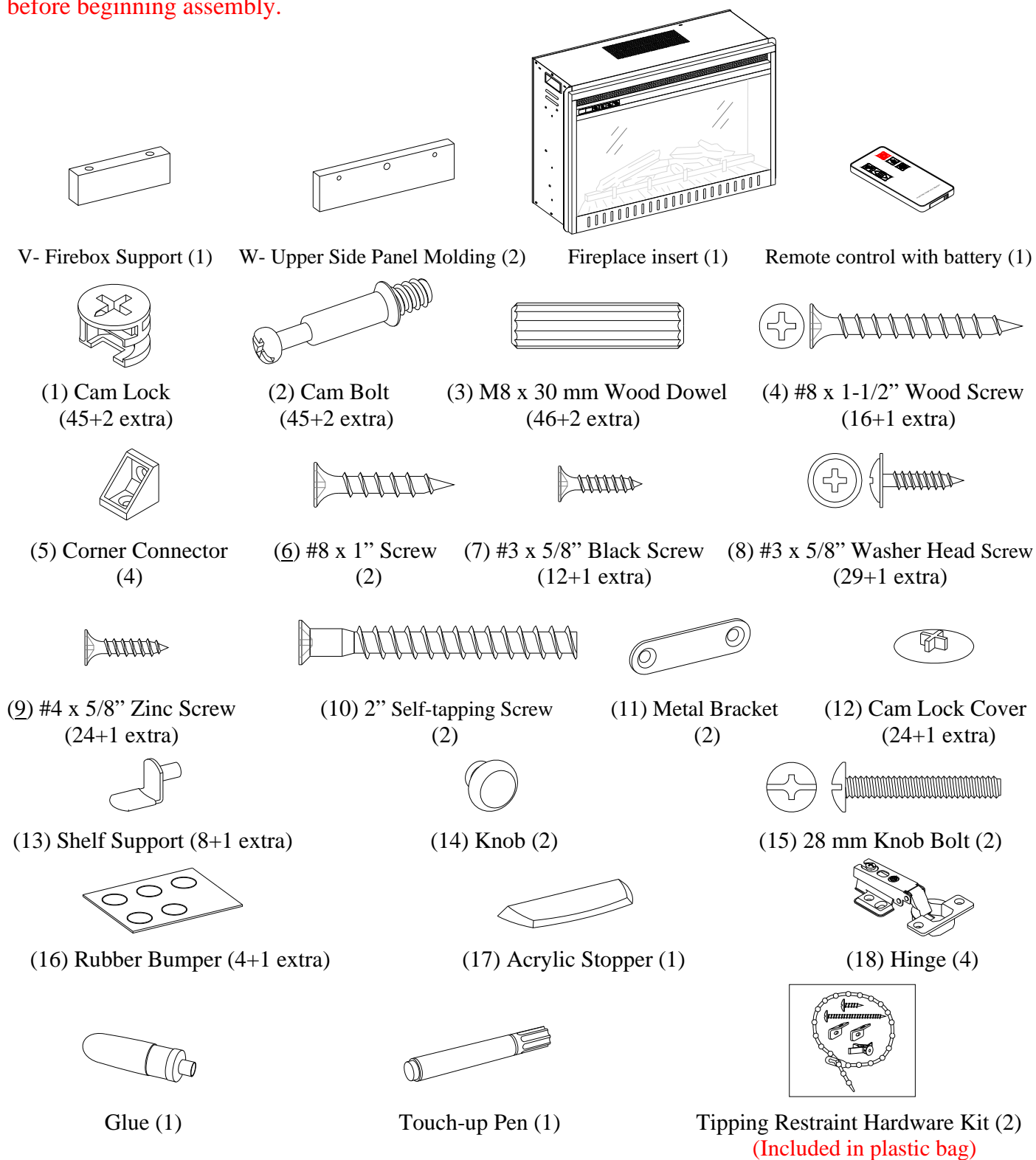

Tools required: Phillips screwdriver and hammer (not provided).

Please call for replacement parts or assistance: **1-866-942-5362**

Assembly Instructions

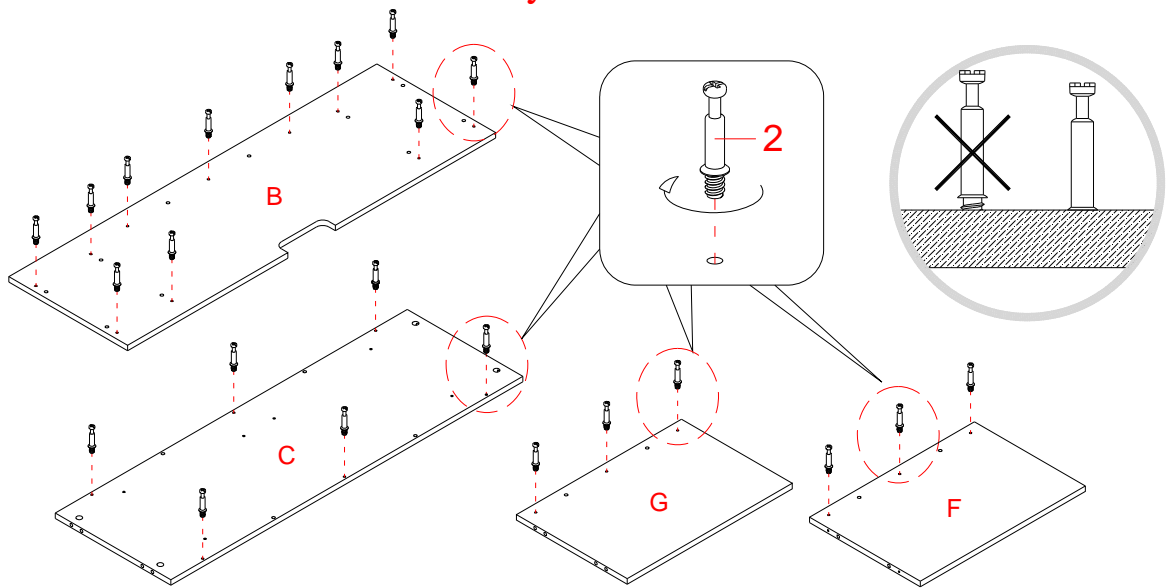

1. Unpack the unit and confirm that you have all the hardware and required parts. Assembly the unit on a carpeted floor or the empty carton to avoid any scratch.
2. Secure screw the Cam Bolts (2) into the designated small holes on the Fixed Shelf (B), Bottom Panel (C) and Lower Partition Panels (F and G) by a Phillips screwdriver, as shown in the illustration.

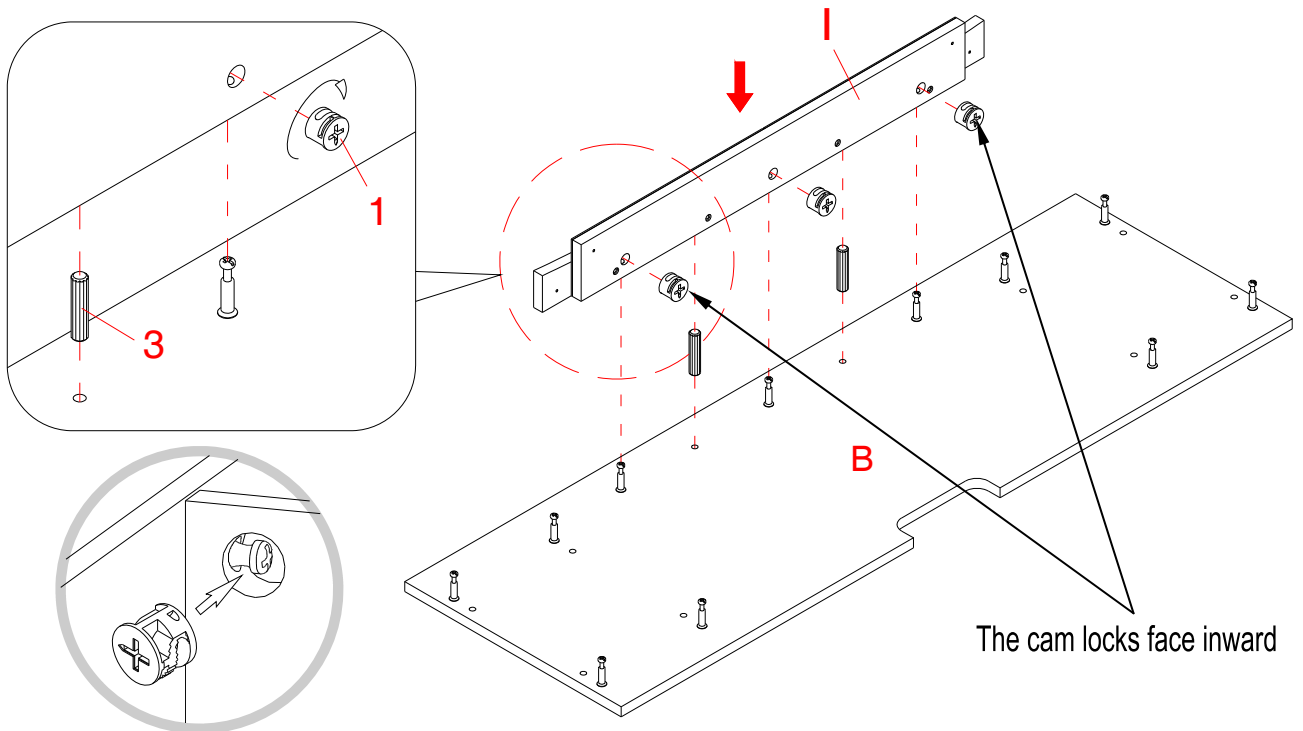

3. Insert two Wood Dowels (3) into the inner holes of Middle Crossbar Assembly (I). Tap it in with a rubber mallet, if necessary. Make sure that you use a small amount of glue with both ends of all dowels.
4. Align the drilled holes on the Fixed Shelf (B) with the inserted Wood Dowel (3) on the Middle Crossbar Assembly (I), and then press them together. Attach the Middle Crossbar Assembly (I) in place by engaging three Cam Locks (1) (Refer to page 3 on Cam Lock system operation supplement).

Please call for replacement parts or assistance: **1-866-942-5362**

Assembly Instructions

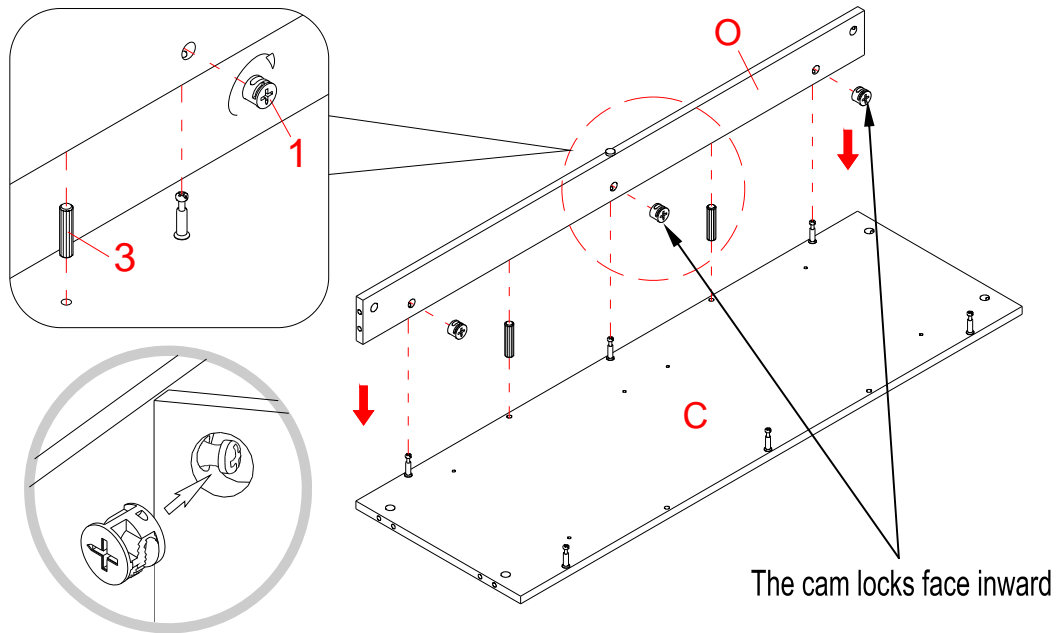

5. Align and attach the Bottom Rear Stretcher (O) to the Bottom Panel (C) by using two wood dowels (3) and three cam locks (1). As shown.

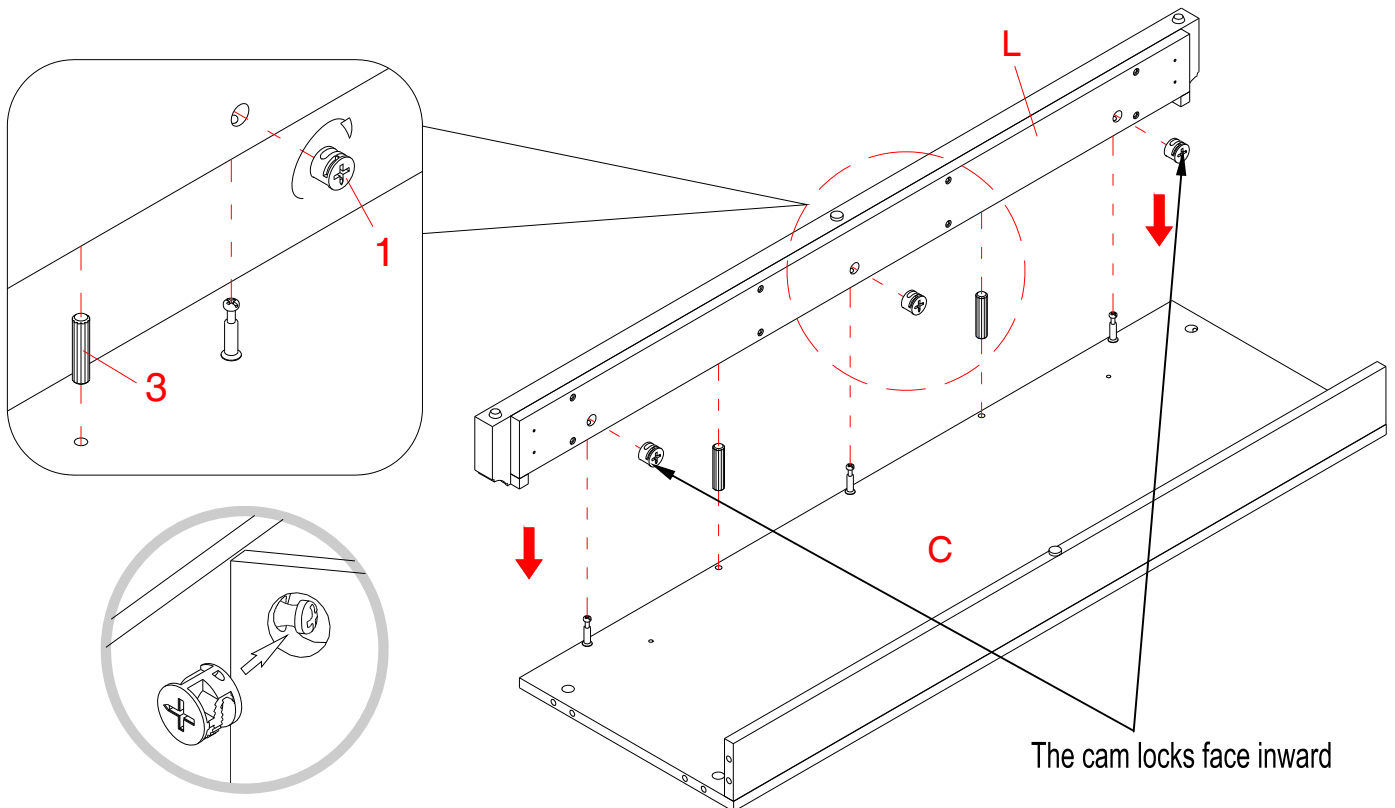

6. Align and attach the Base Front Molding (L) to the Bottom Panel (C) by using two wood dowels (3) and three cam locks (1).

Please call for replacement parts or assistance: **1-866-942-5362**

Assembly Instructions

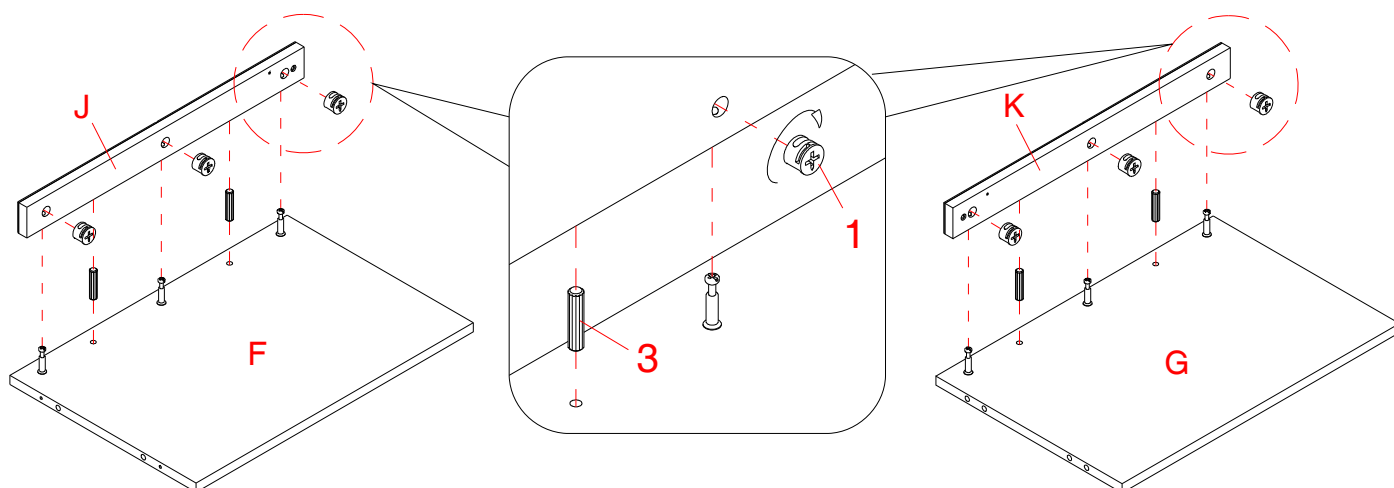

7. Align and attach the Middle Left Stringer (J) to the Left Lower Partition Panel (F) by using two Wood Dowels (3) and three Cam Locks (1).
8. Repeat the same procedure to combine the Middle Right Stringer (K) with the Right Lower Partition Panel (G) together.

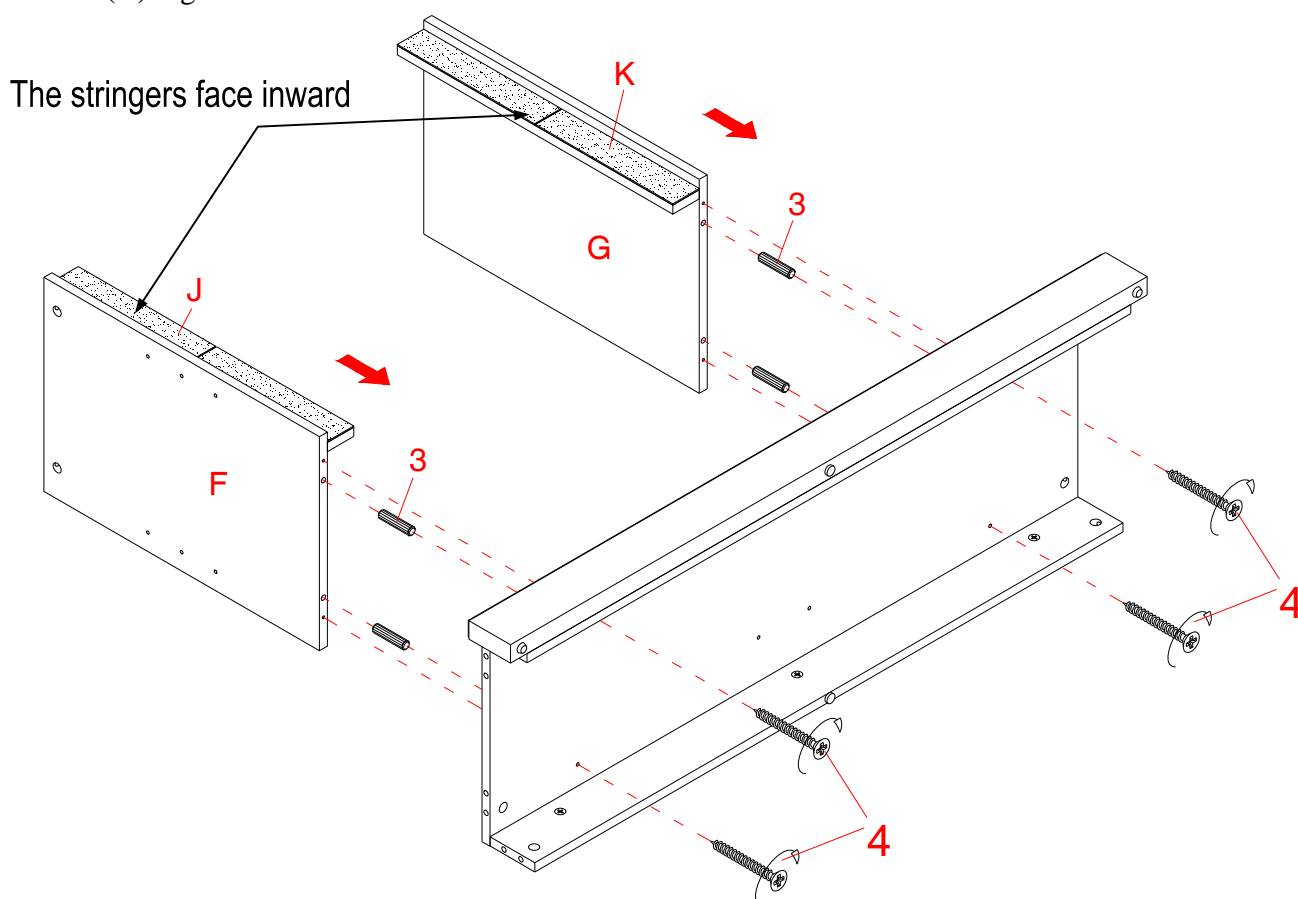

9. Insert four Wood Dowels (3) into the inner holes of the Lower Partition Panels (F and G) and attach them to the Bottom Panel (C) by using four 1-1/2" Wood Screws (4).

Please call for replacement parts or assistance: **1-866-942-5362**

Assembly Instructions

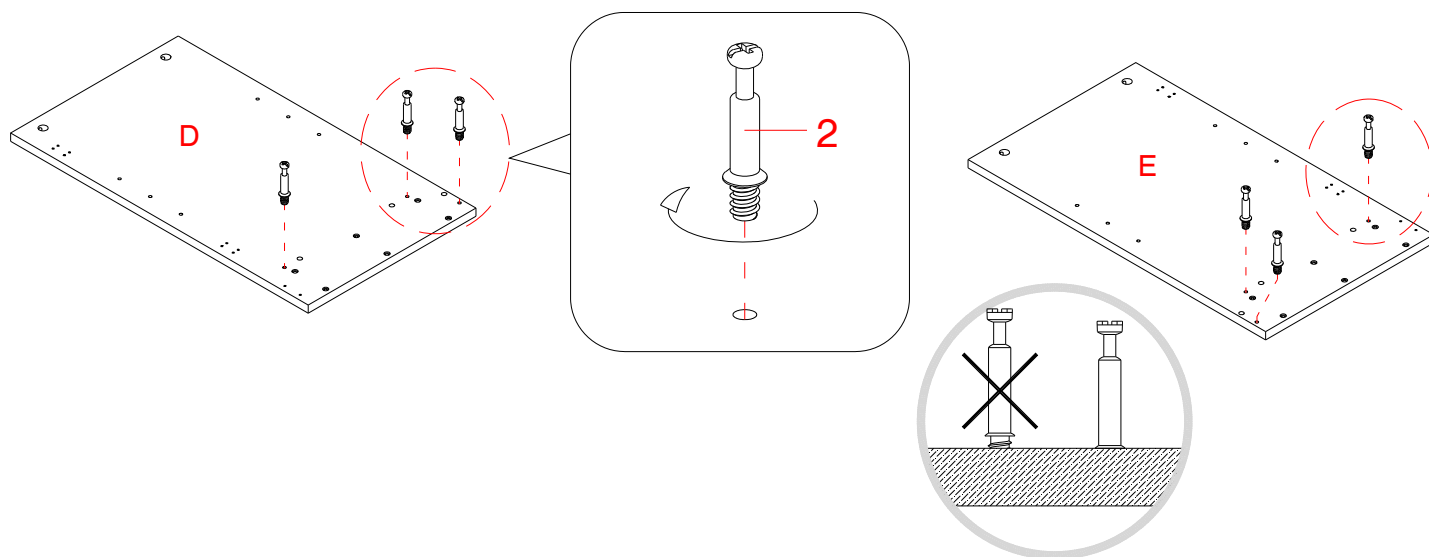

10. Securely screw the Cam Bolts (2) into the designated small holes on the Left and Right Side Panels (D and E) by a Phillips screwdriver.

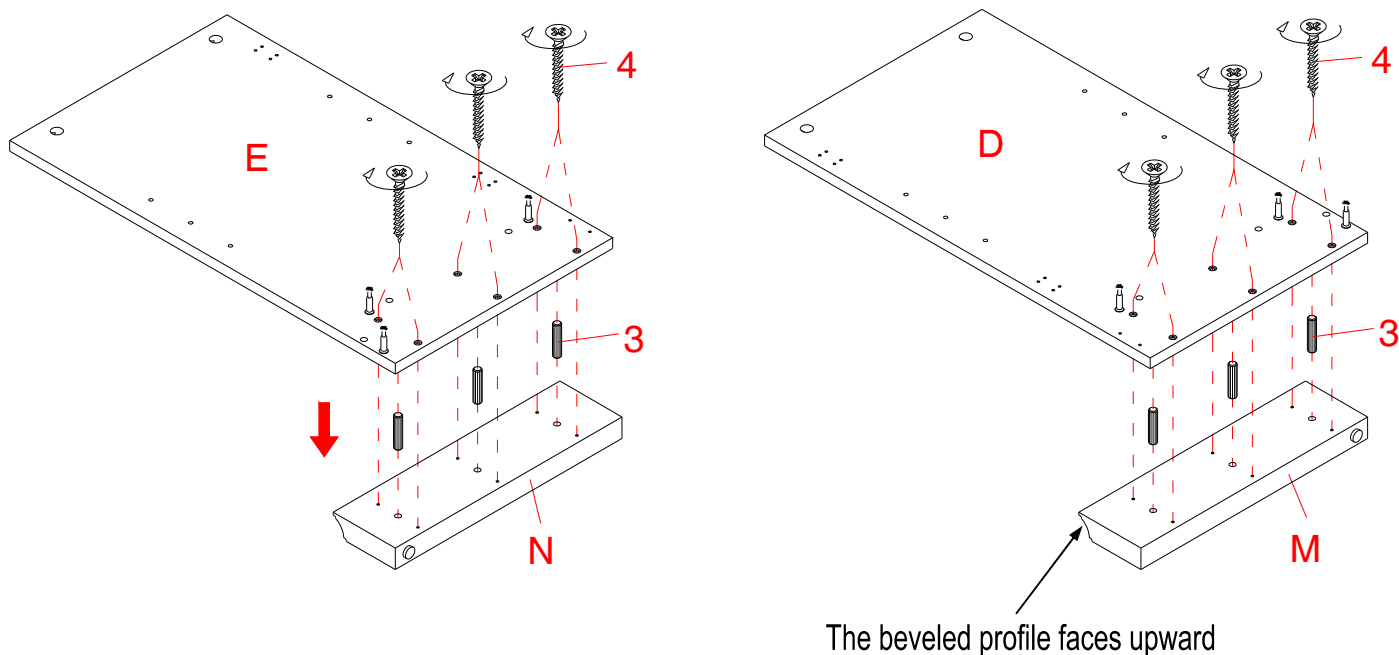

11. Insert three Wood Dowels (3) into the inner holes on Left Bottom Molding (M) and fasten it to the Left Lower Side Panel (D) with six 1-1/2" Wood Screws (4).
12. Repeat last step to combine the Right Bottom Molding (N) with the Right Lower Side Panel (E) together.

Assembly Instructions

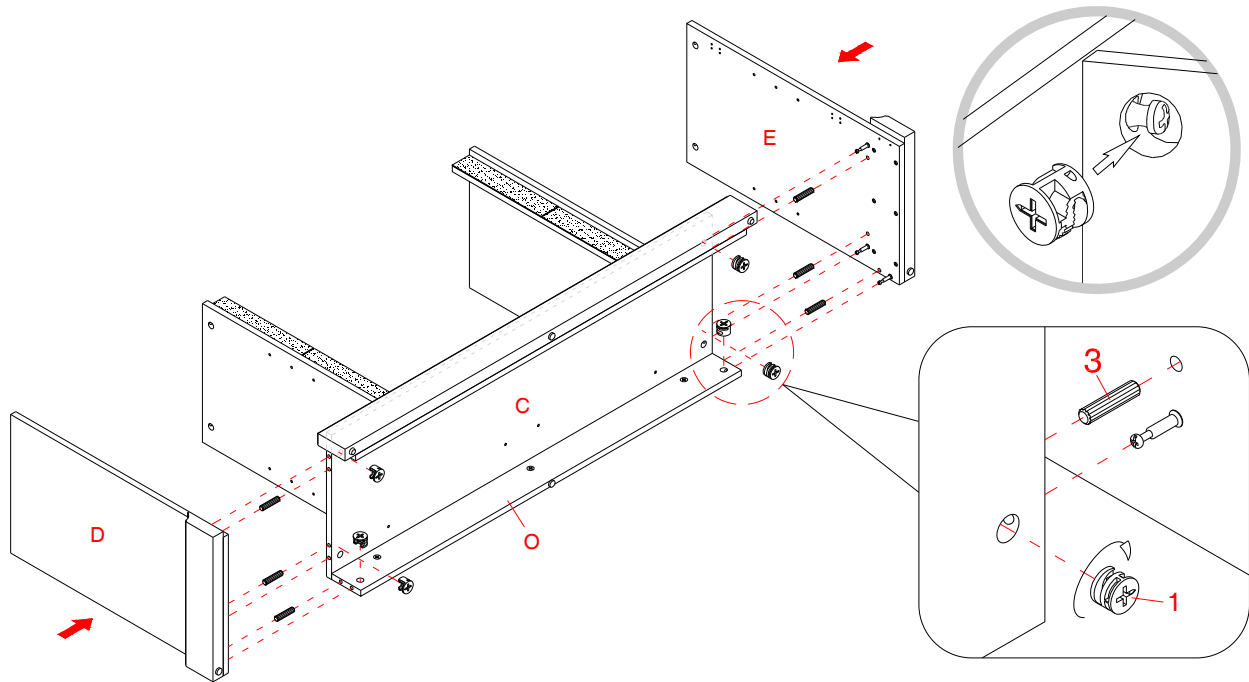

13. Insert six Wood Dowels (3) into the large holes of the assembled base at both ends.
14. Align the large holes on Left Lower Side Panel (D) with the inserted Wood Dowels (3) on the assembled base. Firmly press them together and fasten it in place by engaging three Cam Locks (1).
15. Repeat last step to attach Right Lower Side Panel (E) at the other end.

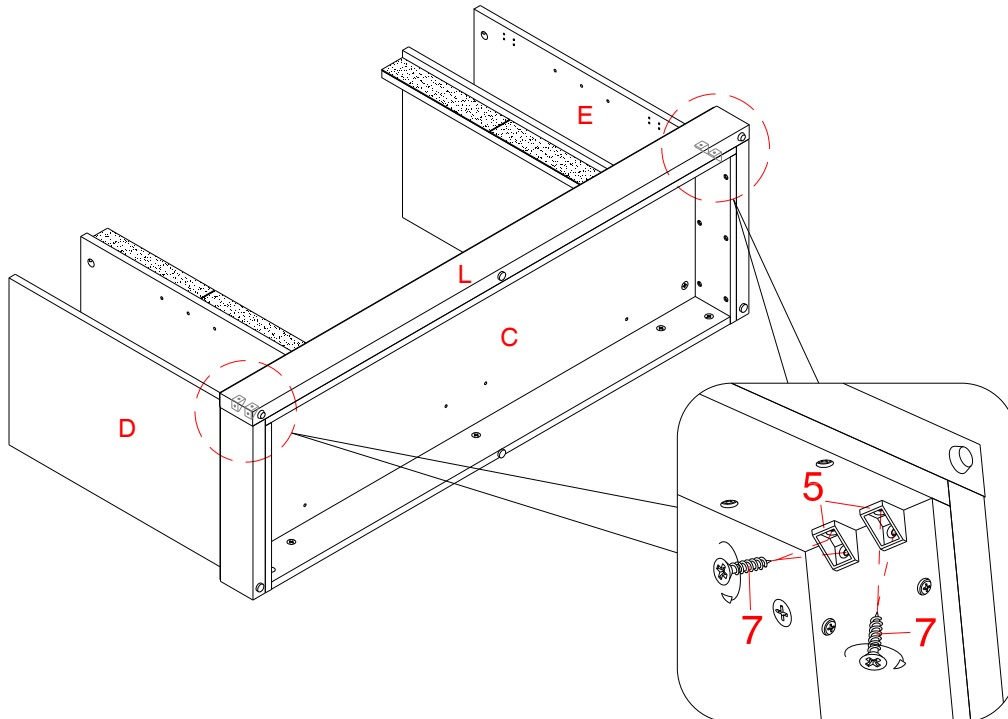

16. With the pilot holes as a guide, attach four Corner Connectors (5) to the middle joints between the Base Front Molding (L) and the Lower Side Panels (D and E) using two 5/8" Screws (7) per bracket.

Please call for replacement parts or assistance: **1-866-942-5362**

Assembly Instructions

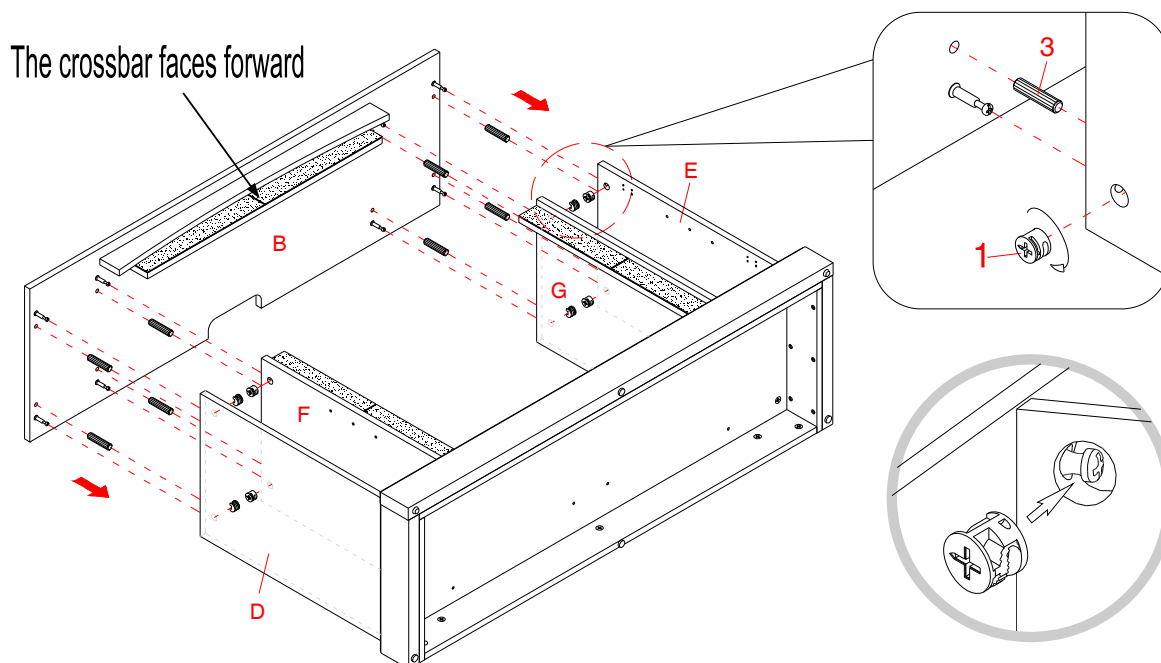

17. Insert eight Wood Dowels (3) into the inner holes on the top edge of the Lower Side Panels and Partition Panels (D, E, F and G).
18. Ask for assistance to position the Fixed Shelf (B) onto the inserted Wood Dowels (3) with the middle crossbar facing forward. Attach the Fixed Shelf (B) in place by engaging eight Cam Locks (1).

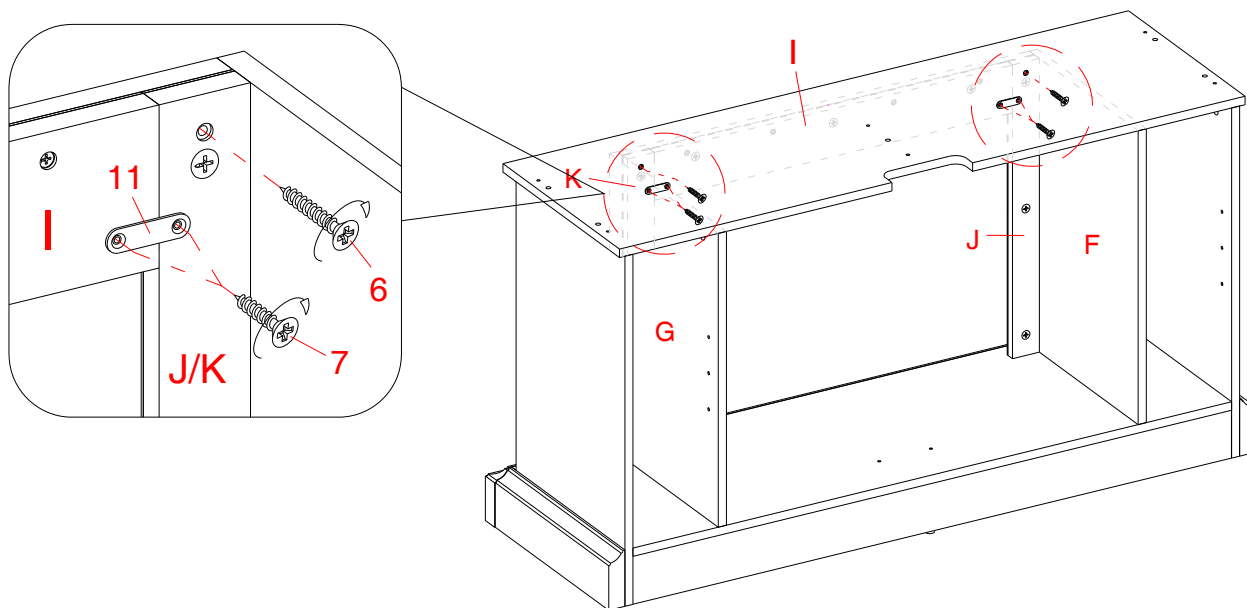

19. Stand the assembled unit upright.
20. Fasten the Middle Crossbar Assembly (I) to the Middle Left and Right Stringers (J and K) by attaching two Metal Brackets (11) at the joints, using two 5/8" Black Screws (7) per Bracket.
21. Insert two 1" Screws (6) through the countersunk holes on the Middle Left and Right Stringers (J and K) and screw into the Middle Crossbar Assembly (I) as shown.

Please call for replacement parts or assistance: **1-866-942-5362**

Assembly Instructions

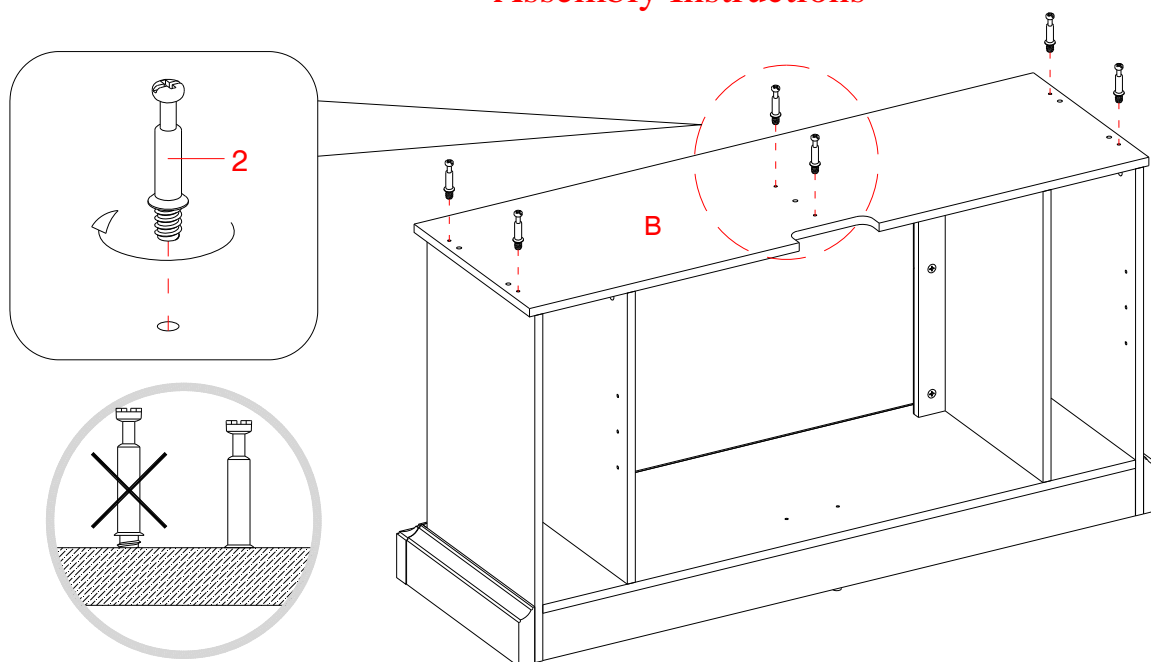

22. Securely screw six Cam Bolts (2) into the designated small holes on the Fixed Shelf (B) by a Phillips screwdriver.

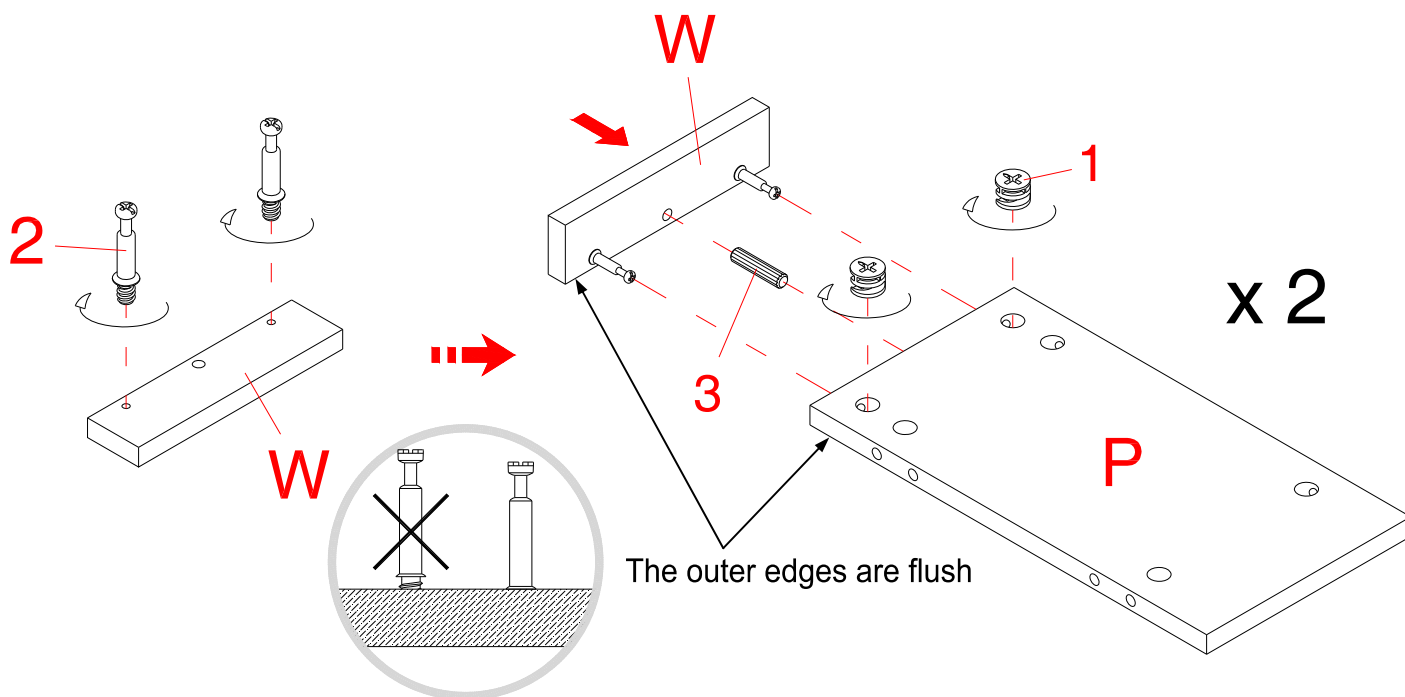

23. Securely screw two Cam Bolts (2) into the designated small holes on one Upper Side Panel Molding (W) by a Phillips screwdriver.

24. Fasten the Upper Side Panel Molding (W) to one Upper Side Panel (P) using one Wood Dowel (3) and two Cam Locks (1).

25. Repeat the same procedure to combine the other Upper Side Panel and Molding (P and W) together.

Please call for replacement parts or assistance: **1-866-942-5362**

Assembly Instructions

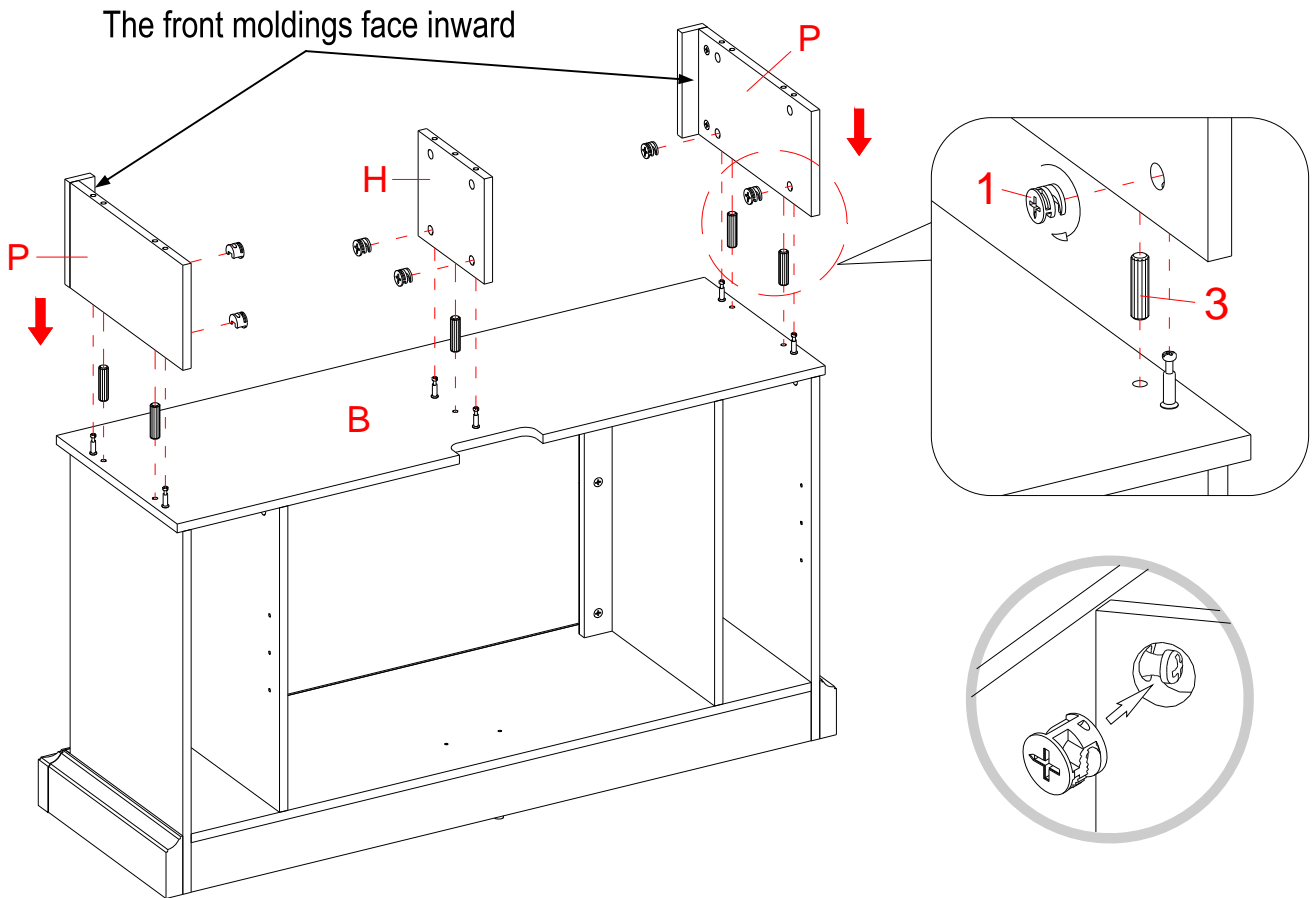

26. Insert five Wood Dowels (3) into the large holes on the Fixed Shelf (B). Attach the assembled Upper Side Panels (P) and Partition Panel (H) to the Fixed Shelf (B) by using six Cam Locks (1).

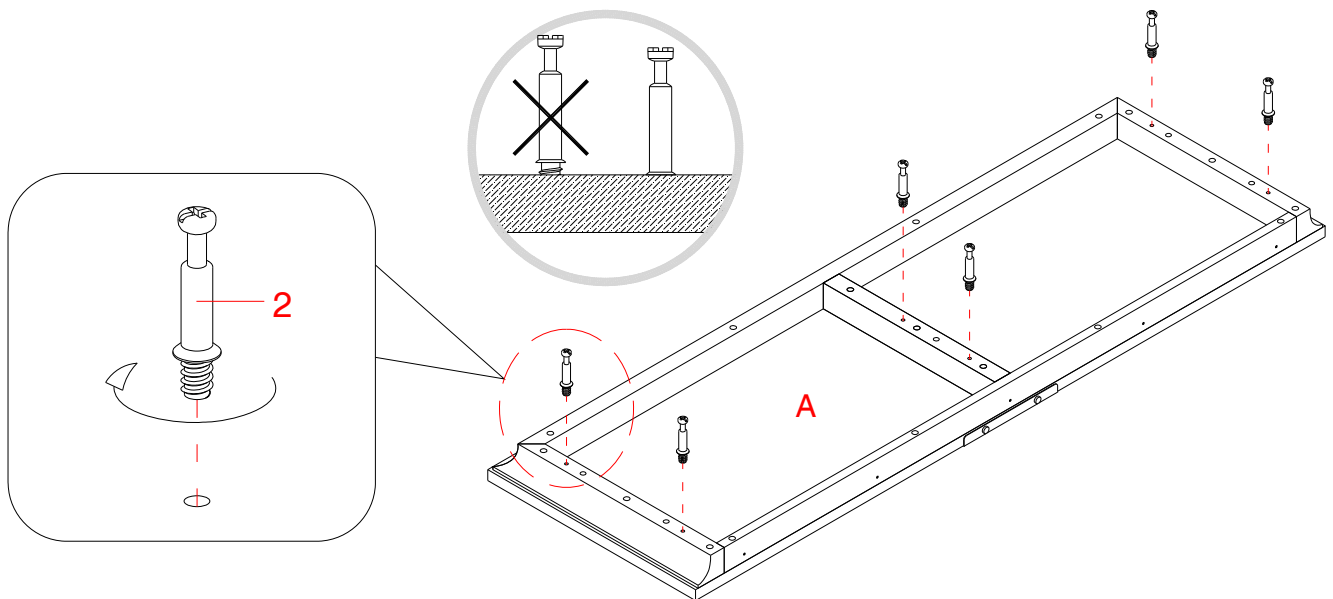

27. Securely screw six Cam Bolts (2) into the designated small holes on Top Panel (A) by a Phillips screwdriver.

Please call for replacement parts or assistance: **1-866-942-5362**

Whalen Furniture Manufacturing

Page 13

Factory No. 17152

Assembly Instructions

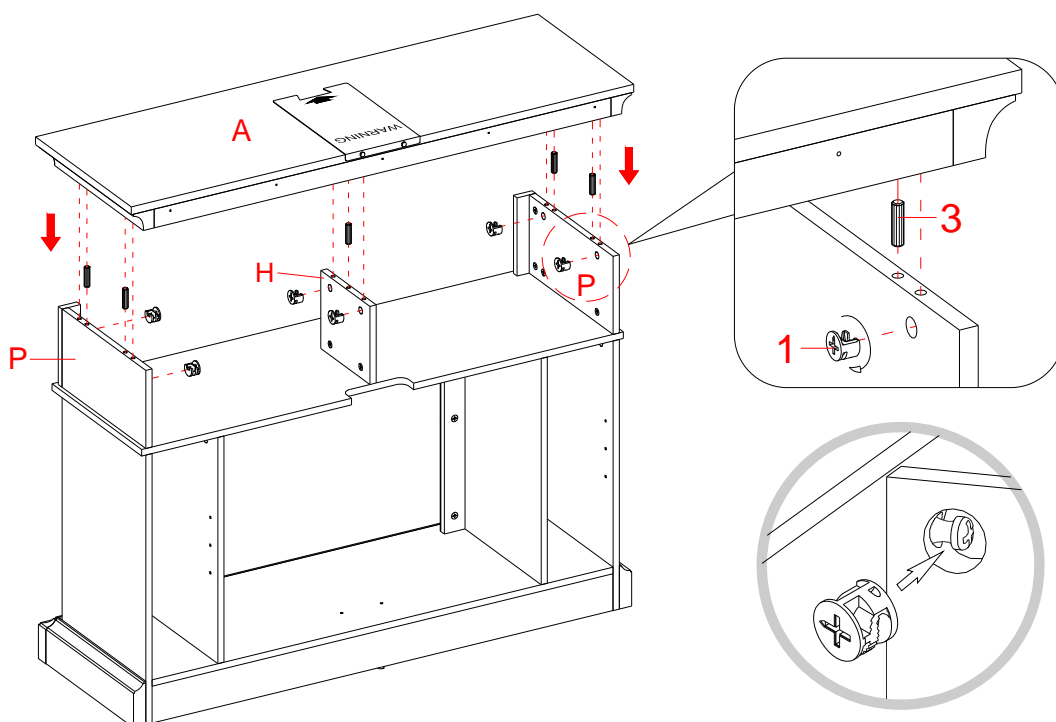

28. Insert 5 Wood Dowels (3) into the top inner holes of the Upper Partition Panel (H) and Side Panels (P). Position the Top Panel (A) onto the inserted Wood Dowels (3) and fasten it in place with 6 Cam Locks (1).

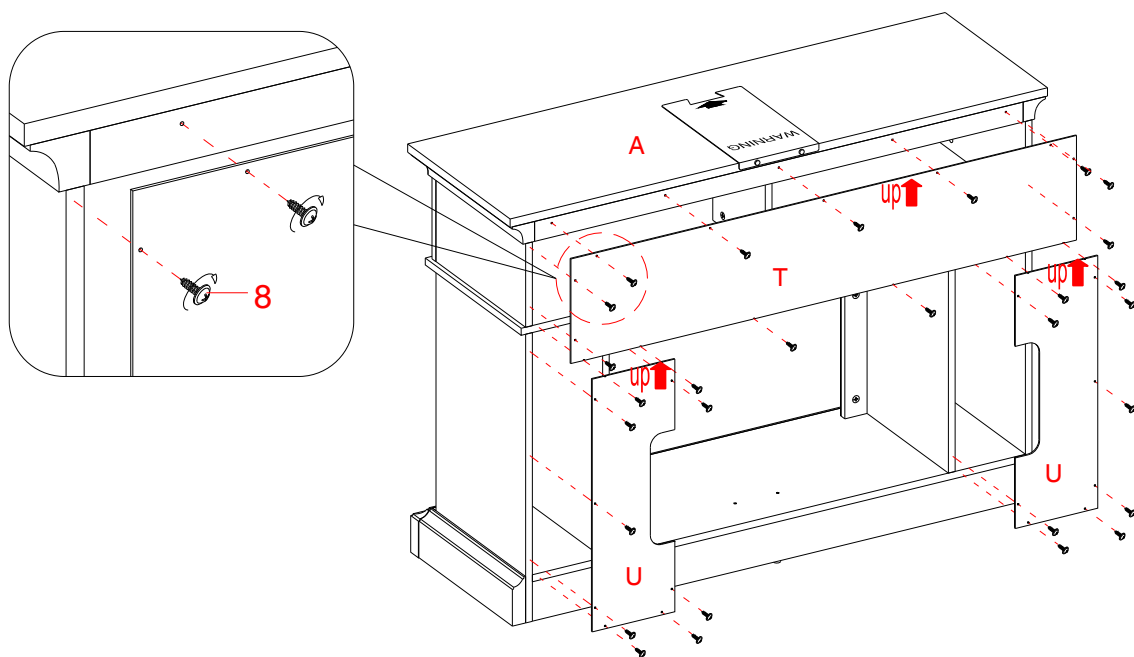

29. Pick up the Upper Back Panel (T) and align the pre-drilled holes against the upper long edge with the pilot holes on the back stretcher of Top Panel (A). Attach the Back Panel (T) in place using the provided Washer Head Screws (8).
30. Align and attach two Lower Back Panels (U) to the mantel base with the provided Washer Head Screws (8).

Please call for replacement parts or assistance: **1-866-942-5362**

Assembly Instructions

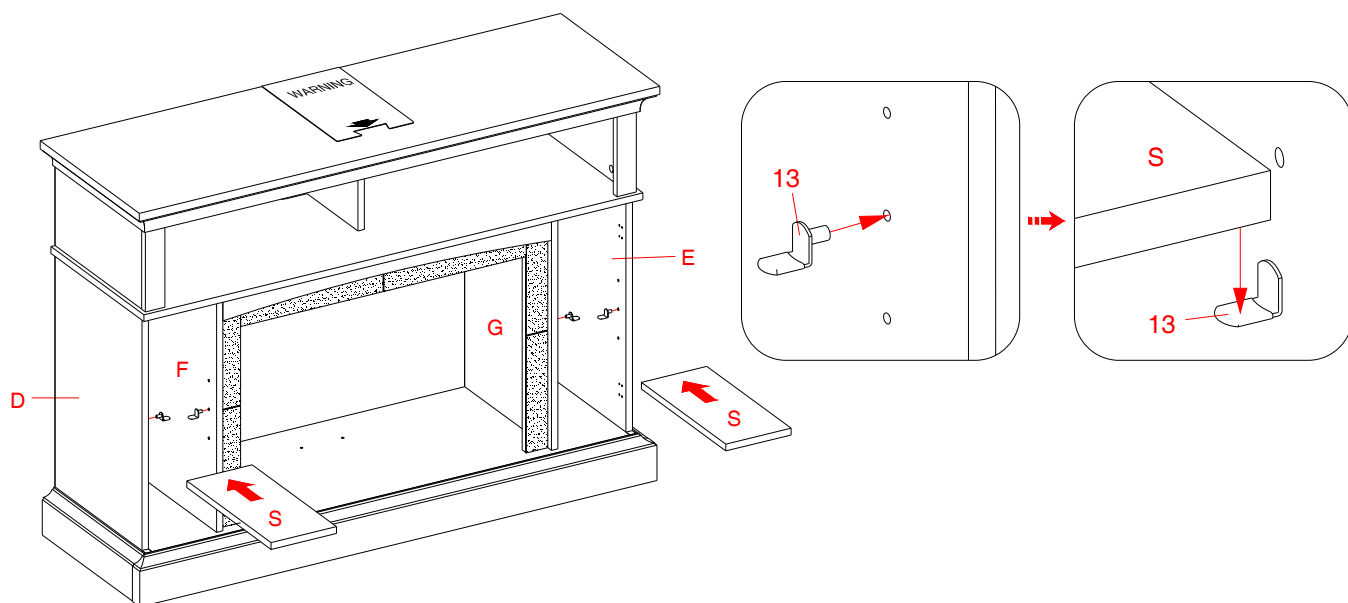

31. Insert four Shelf Supports (13) into the holes at your desired height inside each compartment. Tilt and rest the Adjustable Shelves (S) onto the Shelf Supports (13).

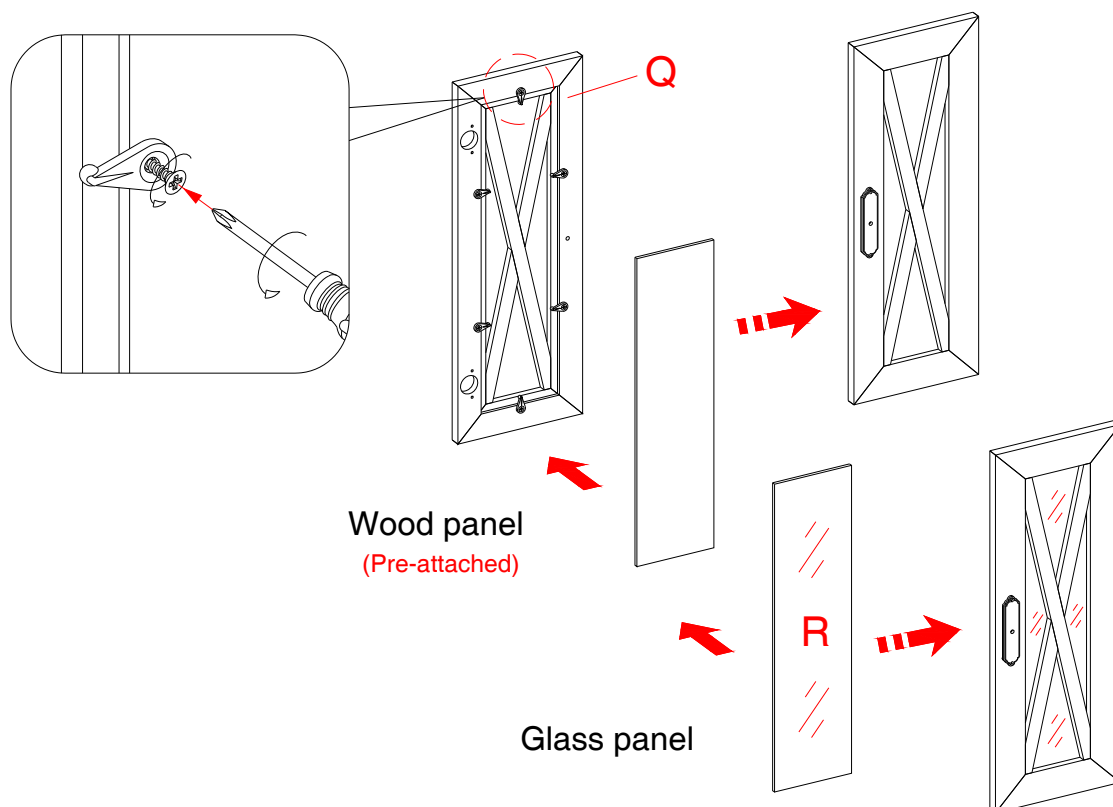

Note: The doors are shipped with Wood Door Panel. You can keep the door as it is or interchange with Glass Door Panel (R) depending on your configuration.

32. To change configuration, loosen the screws on the inside of Door Panels (Q) and rotate the clips to remove the door insert panel. Replace with desired panel, then rotate clips to secure the panel within the door frame and tighten screws.

Please call for replacement parts or assistance: **1-866-942-5362**

Assembly Instructions

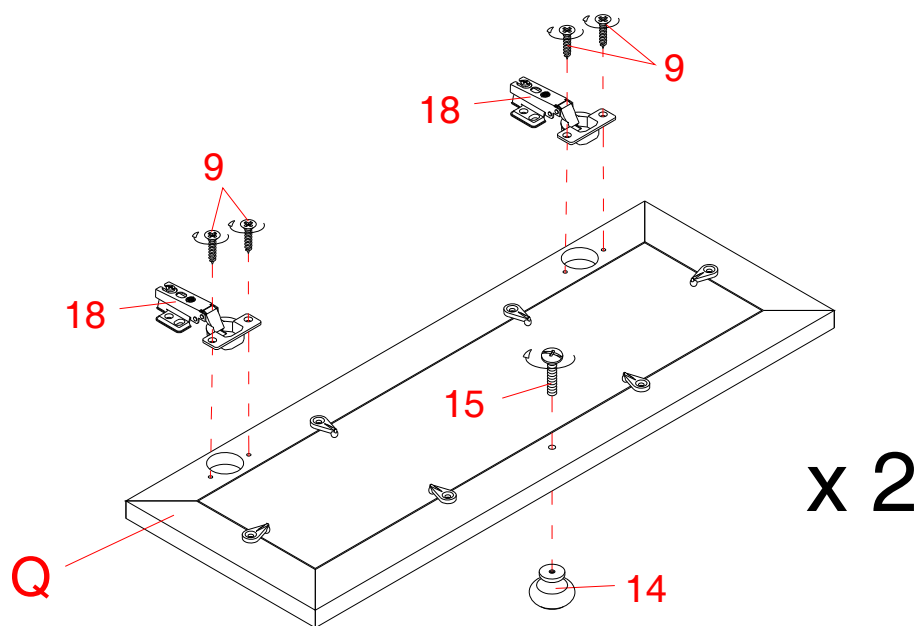

33. Extend the Door Hinges (18) and rest the hinge cups onto the cutouts of one Door Panel (Q). Secure the Door Hinges (18) in place by using two 5/8" Zinc Screws (9) in each.
34. Attach one Knob (14) to the front side of the Door (Q) with one Knob Bolt (15).
35. Repeat the same procedure with the other Door Panel (Q).

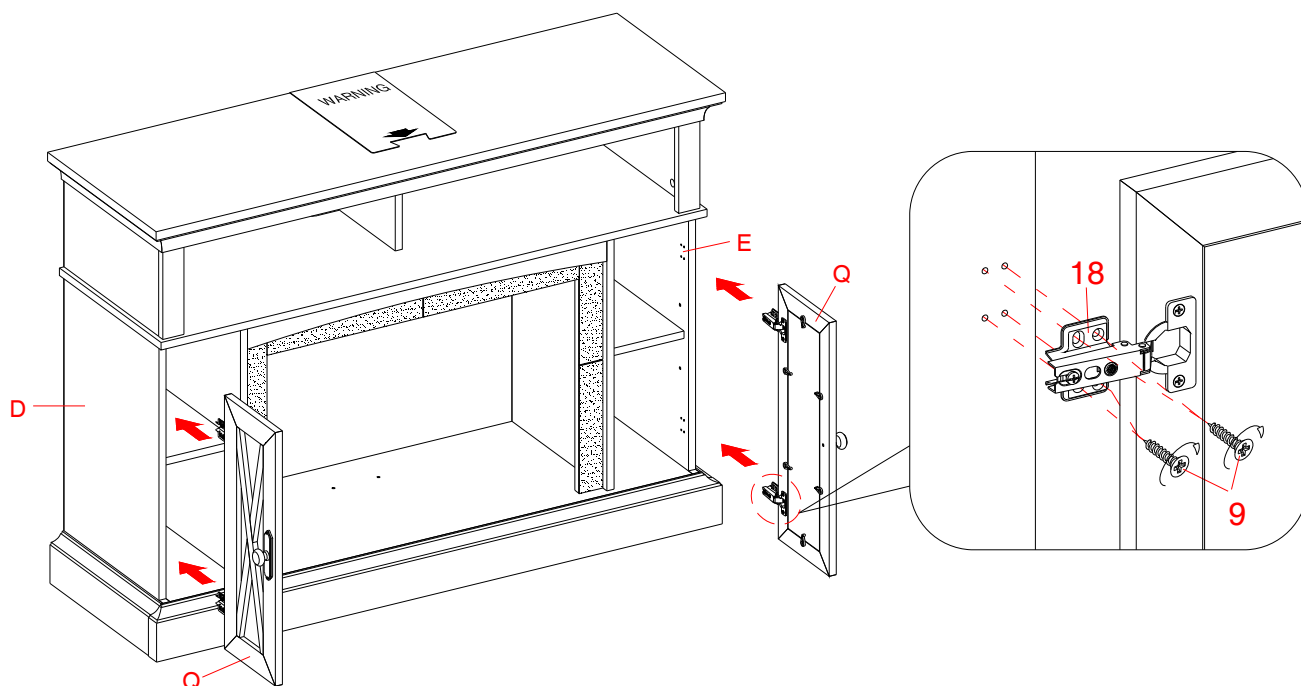

36. Pick up one Door Panel (Q) and fasten the Hinge Bases (18) onto the Left Lower Side Panel (D) with four 5/8" Zinc Screws (9) in each. **DO NOT fully tighten the screws.**
37. Repeat the same procedure to attach the other Door (Q) to the Right Lower Side Panel (E).
38. Open and close the doors to make sure they are aligned and shut correctly. If necessary, adjust the screws for a good fit. Refer to the hinge sticker on door for adjustment.

Please call for replacement parts or assistance: **1-866-942-5362**

Assembly Instructions

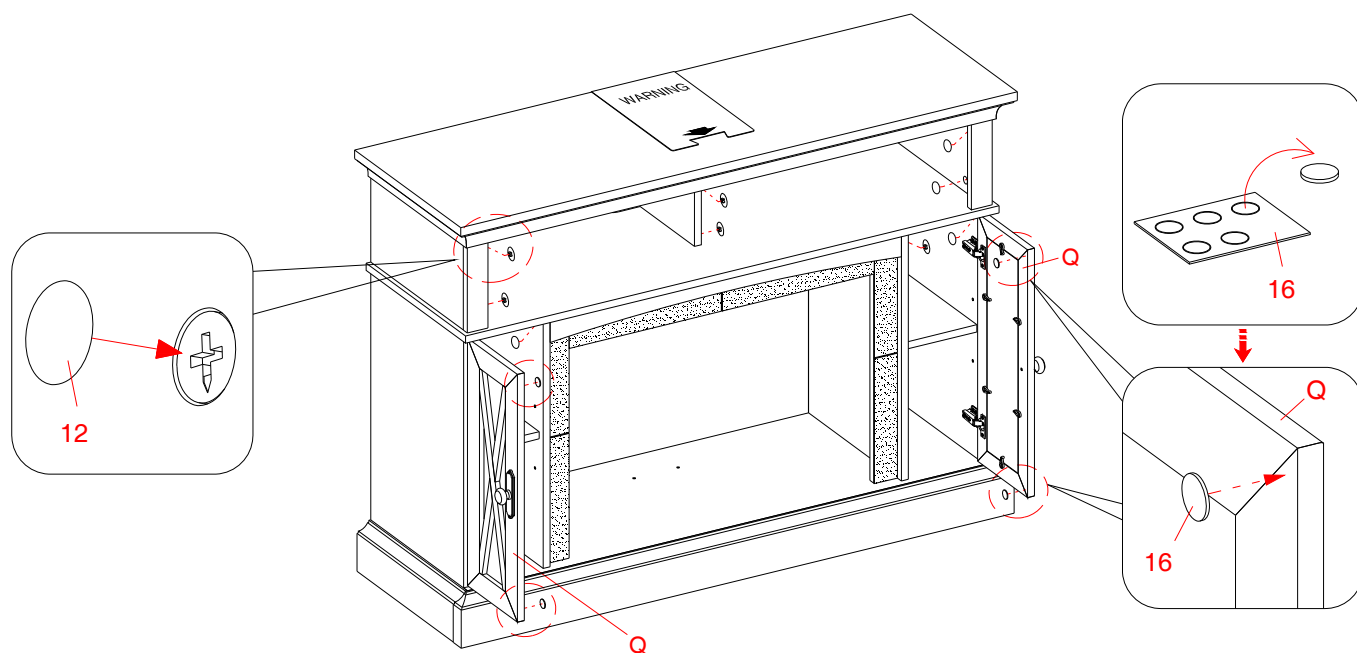

39. Plug the Cam Lock Covers (12) onto the visible cams locks to conceal the cams.

40. Stick the Rubber Bumpers (16) on the outer corners of Doors (Q) as shown.

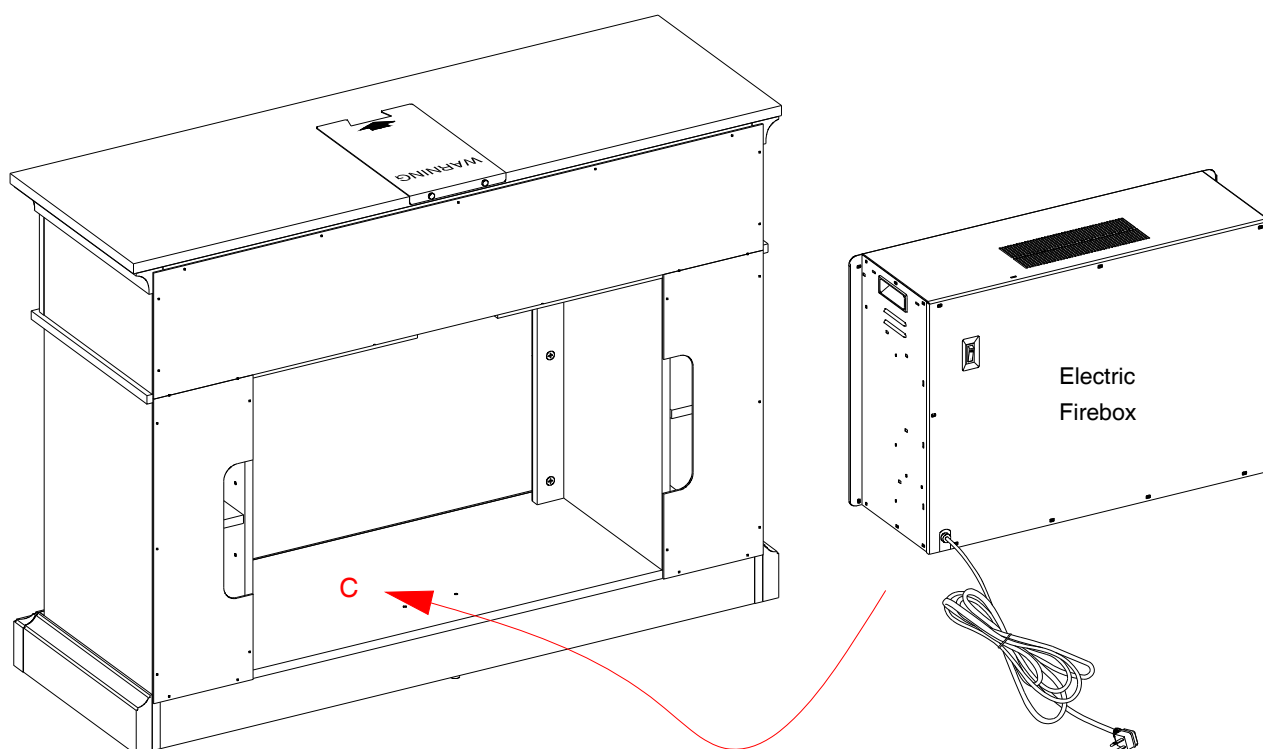

41. Lift the fireplace insert carefully into the back of the assembled mantel and center it in the opening. DO NOT drag the insert across the Bottom Panel (C) as it may scratch the unit.

Please call for replacement parts or assistance: **1-866-942-5362**

Whalen Furniture Manufacturing

Page 17

Factory No. 17152

Assembly Instructions

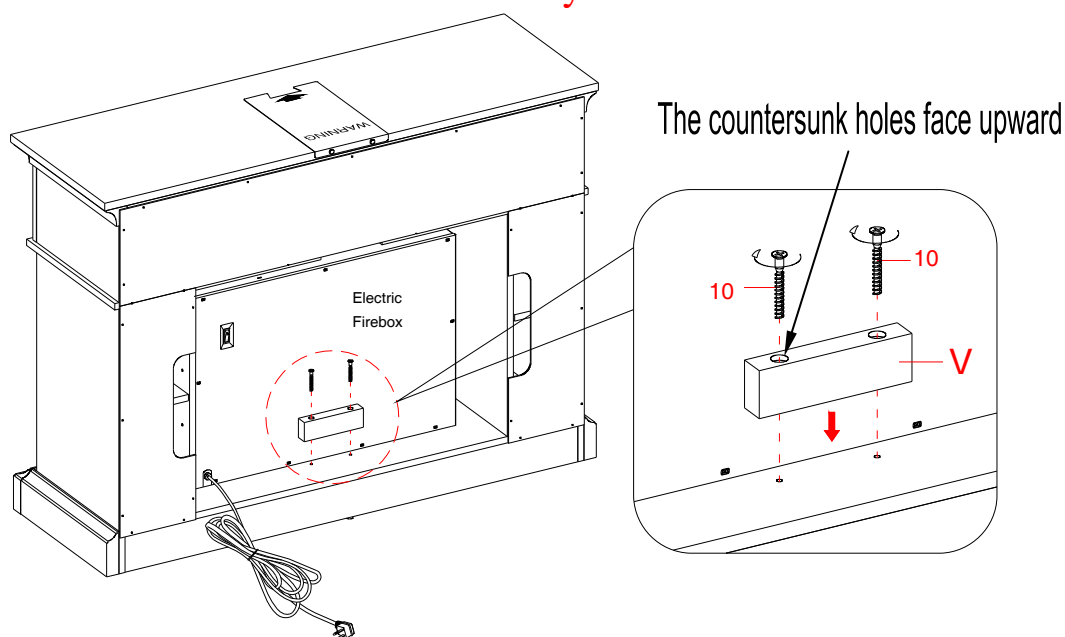

42. Align and attach the Firebox Support (V) to the Bottom Panel (C) by inserting two 2" Self-tapping Screws (10) through the countersunk holes and screw into place.

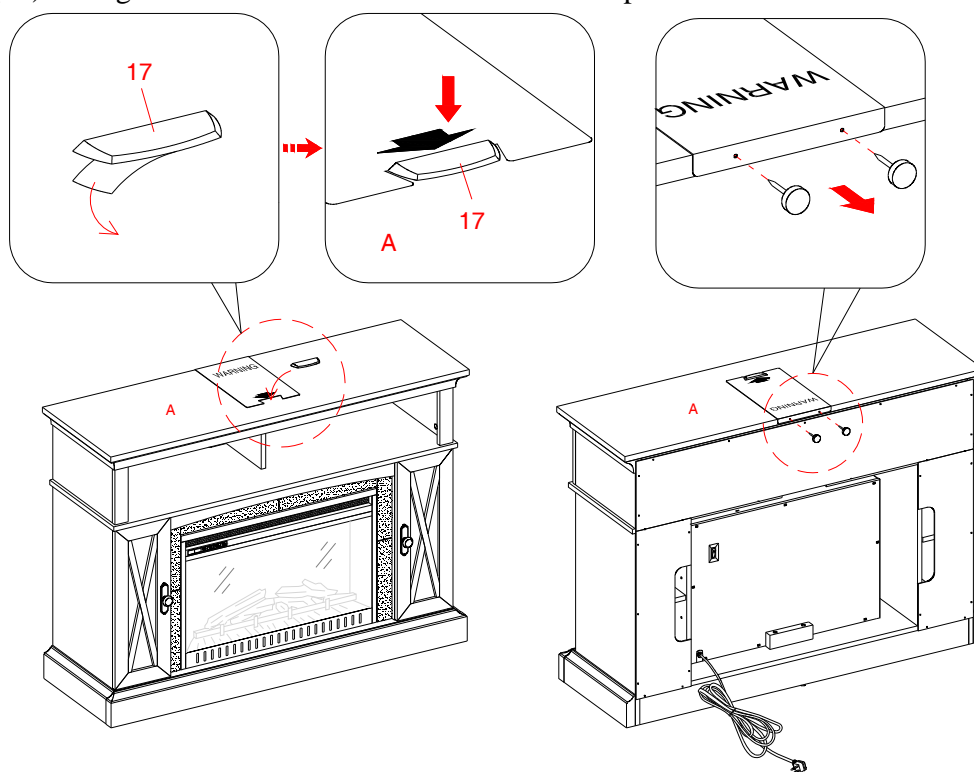

NOTE: You must install the Acrylic TV Stopper to prevent the TV from tipping when placing your flat panel television directly on the console.

43. Remove the paper backing of acrylic stopper (17), then properly align the acrylic stopper into the cut-out on the acrylic stopper template on the top panel (A). Press down on the acrylic stopper to help adhesion.
44. At the back of Top Panel (A), carefully unscrew two thumb tacks to remove the acrylic stopper template.

Please call for replacement parts or assistance: **1-866-942-5362**

Whalen Furniture Manufacturing

Page 18

Factory No. 17152

Assembly Instructions

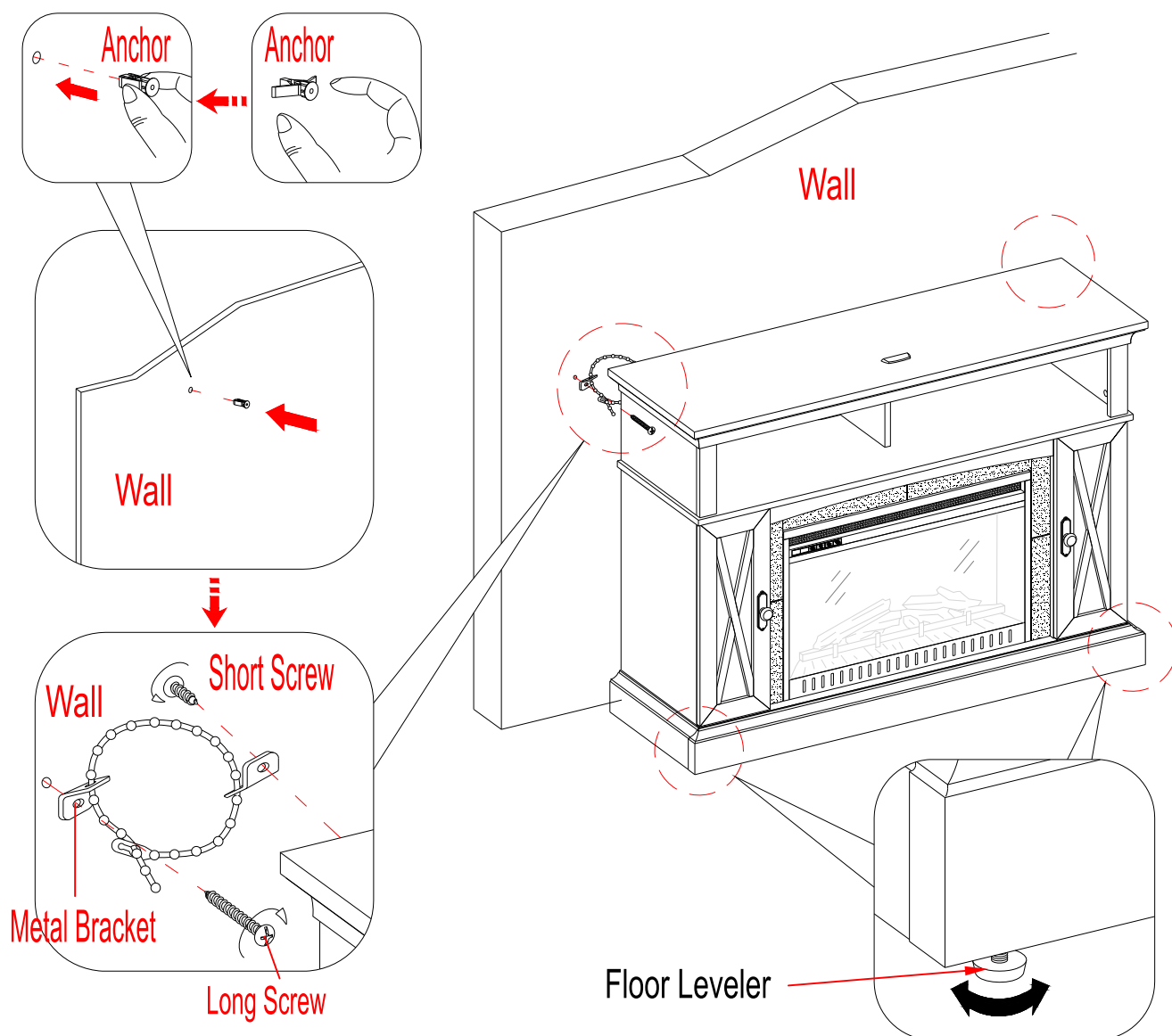

Tools required: Phillips screwdriver, Power Drill, 3/8" Drill Bit and Rubber Mallet.

45. Ask for assistance to position the assemble fireplace at the desired location against a wall. If necessary, adjust the pre-attached Floor Levelers at the bottom of the Base Front Molding (L) to level the unit. Now, follow the instructions printed on the plastic bag containing the Tipping Restraint Hardware to attach the tip-over restraints to the unit and the wall.

NOTE: Young children can be seriously injured by tipping furniture. You must install the Tipping Restraint Hardware with the unit to prevent the unit from tipping, causing any accidents or damage. The tipping restraint is intended only as a deterrent, they are not a substitute for proper adult supervision. The tipping restraint is not an earthquake restraint. If you wish to add the extra security of earthquake restraints, they must be purchased and installed separately.

46. Connect the fireplace to the power transformer. Follow the operating manual for the electric fireplace insert to control your fireplace.

Please call for replacement parts or assistance: **1-866-942-5362**

Whalen Furniture Manufacturing

Page 19

Factory No. 17152

Care and Maintenance

- Use a soft, clean cloth that will not scratch the surface when dusting.
- Use of furniture polishes is not necessary. Should you choose to use polishes, test first in an inconspicuous area.
- Using solvents of any kind on your furniture may damage the finish.
- Never use water to clean your furniture as it may cause damage to the finish.
- Always use coasters under beverage glasses and flowerpots.
- Liquid spills should be removed immediately. Using a soft clean cloth, blot the spill gently. Avoid rubbing.
- Always use protective pads under hot dishes and plates. Heat can cause chemical changes that may create spotting within the furniture finish.
- Stains or marks from crayons or ink markers will be difficult to remove.
- In the event that your furniture is stained or otherwise damaged during use, we recommend that you call a professional to repair your furniture.
- Check bolts/screws periodically and tighten them if necessary.

Further advice about wood furniture care

It is best to keep your furniture in a climate-controlled environment. Extreme temperature and humidity changes can cause fading, warping, shrinking and splitting of wood. It is advised to keep furniture away from direct sunlight as sun may damage the finish.

Proper care and cleaning at home will extend the life of your purchase. Following these important and helpful tips will enhance your furniture as it ages.

A Touch-up Pen has been provided to repair any small nicks or scratches that may occur during assembly or shipping.

Cleaning trim for fireplace

Clean the metal trim using a soft cloth, slightly dampened with citrus oil based product and buff with a clean soft cloth. **DO NOT** use brass polish or household cleaners as these products will damage the metal trim. Citrus oil based products can be obtained at supermarkets or hardware stores.

We hope you enjoy your purchase for many years.
Thank you for your purchase!

Please call for replacement parts or assistance: 1-866-942-5362

IF YOU NEED TO ORDER ANY REPLACEMENT PARTS, PLEASE USE THE LIST BELOW

Sheldon 48" Fireplace (WSF48SH26C)

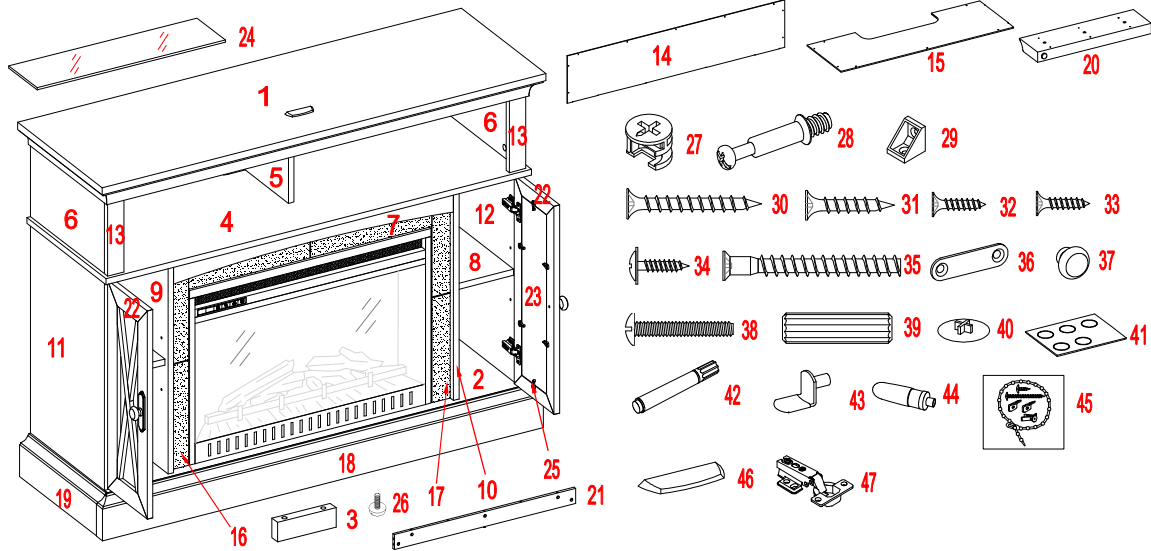

*WSF48SH26C-1-TP	Top Panel	*WSF48SH26C-32-5/8FHZS	#3 x 5/8" Flat Head Zinc Screw
*WSF48SH26C-2-BP	Bottom Panel	*WSF48SH26C-33-5/8FHBS	#3 x 5/8" Flat Head Black Screw
*WSF48SH26C-3-FS	Firebox Support	*WSF48SH26C-34-5/8WHS	#3 x 5/8" Washer Head Screw
*WSF48SH26C-4-FS	Fixed Shelf	*WSF48SH26C-35-2SS	2" Self-tapping Screw
*WSF48SH26C-5-UPP	Upper Partition Panel	*WSF48SH26C-36-MB	Metal Bracket
*WSF48SH26C-6-USP	Upper Side Panel	*WSF48SH26C-37-K	Knob
*WSF48SH26C-7-MCA	Middle Crossbar Assembly	*WSF48SH26C-38-KB	Knob Bolt
*WSF48SH26C-8-AS	Adjustable Shelf	*WSF48SH26C-39-M8x30WD	M8 x 30 mm Wood Dowel
*WSF48SH26C-9-LLPP	Left Lower Partition Panel	*WSF48SH26C-40-CLC	Cam Lock Cover
*WSF48SH26C-10-RLPP	Right Lower Partition Panel	*WSF48SH26C-41-RB	Rubber Bumper
*WSF48SH26C-11-LLSP	Left Lower Side Panel	*WSF48SH26C-42-TUP	Touch-up Pen
*WSF48SH26C-12-RLSP	Right Lower Side Panel	*WSF48SH26C-43-SS	Shelf Support
*WSF48SH26C-13-USPM	Upper Side Panel Molding	*WSF48SH26C-44-G	Glue
*WSF48SH26C-14-UBP	Upper Back Panel	*WSF48SH26C-45-TRHK	Tipping Restraint Hardware Kit
*WSF48SH26C-15-LBP	Lower Back Panel	*WSF48SH26C-46-AS	Acrylic Stopper
*WSF48SH26C-16-MLS	Middle Left Stringer	*WSF48SH26C-47-DH	Door Hinge
*WSF48SH26C-17-MRS	Middle Right Stringer	*WSF48SH26C-48-RC	Remote Control (6-Button)
*WSF48SH26C-18-BFM	Base Front Molding	*WSF48SH26C-49-H	Heater (FP26-1A-THM-H)
*WSF48SH26C-19-LBM	Left Bottom Molding	*WSF48SH26C-50-B	Blower (FP26-1A-THM-B)
*WSF48SH26C-20-RBM	Right Bottom Molding	*WSF48SH26C-51-FGDM	Flame Generator Drive Motor (FP26-1A-THM-FGDM)
*WSF48SH26C-21-BRS	Base Rear Stretcher	*WSF48SH26C-52-RS	Reflector Spindle (FP26-1A-THM-RS)
*WSF48SH26C-22-D	Door	*WSF48SH26C-53-MPCBN	Main PCB (FP26-1A-THM-MPCBN)
*WSF48SH26C-23-DWI	Door Wood Insert	*WSF48SH26C-54-CPPCBN	Control Panel PCB (FP26-1A-THM-CPPCBN)
*WSF48SH26C-24-DGI	Door Glass Insert	*WSF48SH26C-55-LLPCBN	Logs Light PCB (FP26-1A-THM-LLPCBN)
*WSF48SH26C-25-RC	Rubber Clip	*WSF48SH26C-56-EBLPCBN	Ember Bed Light PCB (FP26-1A-THM-EBLPCBN)
*WSF48SH26C-26-FL	Floor Leveler	*WSF48SH26C-57-FLPCBN	Flame Light PCB (FP26-1A-THM-FLPCBN)
*WSF48SH26C-27-CL	Cam Lock	*WSF48SH26C-58-FIGF	Fireplace Insert Glass with Frame (FP26-1A-THM-FIGF)
*WSF48SH26C-28-CB	Cam Bolt	*WSF48SH26C-59-EBLN	Ember Bed/Logs (FP26-1A-THM-EBLN)
*WSF48SH26C-29-CC	Corner Connector	*WSF48SH26C-60-T	Thermostat (FP26-1A-THM-T)
*WSF48SH26C-30-1 1/2WS	#8 x 1-1/2" Wood Screw	*WSF48SH26C-CH	Complete Hardware
*WSF48SH26C-31-1S	#8 x 1" Screw	*WSF48SH26C-CFI	Complete Fireplace Insert (FP26-1A-THM)

IF YOU NEED TO ORDER ANY REPLACEMENT PARTS, PLEASE USE THE LIST BELOW

Sheldon 48" Fireplace (WSF48SH26M)

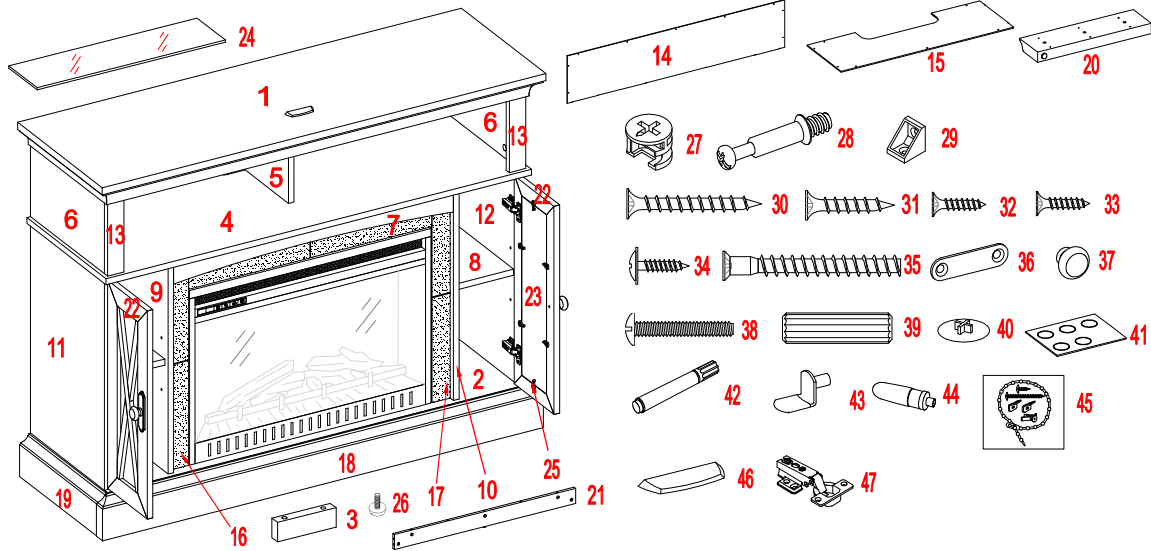

*WSF48SH26M-1-TP	Top Panel	*WSF48SH26M-32-5/8FHZS	#3 x 5/8" Flat Head Zinc Screw
*WSF48SH26M-2-BP	Bottom Panel	*WSF48SH26M-33-5/8FHBS	#3 x 5/8" Flat Head Black Screw
*WSF48SH26M-3-FS	Firebox Support	*WSF48SH26M-34-5/8WHS	#3 x 5/8" Washer Head Screw
*WSF48SH26M-4-FS	Fixed Shelf	*WSF48SH26M-35-2SS	2" Self-tapping Screw
*WSF48SH26M-5-UPP	Upper Partition Panel	*WSF48SH26M-36-MB	Metal Bracket
*WSF48SH26M-6-USP	Upper Side Panel	*WSF48SH26M-37-K	Knob
*WSF48SH26M-7-MCA	Middle Crossbar Assembly	*WSF48SH26M-38-KB	Knob Bolt
*WSF48SH26M-8-AS	Adjustable Shelf	*WSF48SH26M-39-M8x30WD	M8 x 30 mm Wood Dowel
*WSF48SH26M-9-LLPP	Left Lower Partition Panel	*WSF48SH26M-40-CLC	Cam Lock Cover
*WSF48SH26M-10-RLPP	Right Lower Partition Panel	*WSF48SH26M-41-RB	Rubber Bumper
*WSF48SH26M-11-LLSP	Left Lower Side Panel	*WSF48SH26M-42-TUP	Touch-up Pen
*WSF48SH26M-12-RLSP	Right Lower Side Panel	*WSF48SH26M-43-SS	Shelf Support
*WSF48SH26M-13-USPM	Upper Side Panel Molding	*WSF48SH26M-44-G	Glue
*WSF48SH26M-14-UBP	Upper Back Panel	*WSF48SH26M-45-TRHK	Tipping Restraint Hardware Kit
*WSF48SH26M-15-LBP	Lower Back Panel	*WSF48SH26M-46-AS	Acrylic Stopper
*WSF48SH26M-16-MLS	Middle Left Stringer	*WSF48SH26M-47-DH	Door Hinge
*WSF48SH26M-17-MRS	Middle Right Stringer	*WSF48SH26M-48-RC	Remote Control (6-Button)
*WSF48SH26M-18-BFM	Base Front Molding	*WSF48SH26M-49-H	Heater (FP26-1A-THM-H)
*WSF48SH26M-19-LBM	Left Bottom Molding	*WSF48SH26M-50-B	Blower (FP26-1A-THM-B)
*WSF48SH26M-20-RBM	Right Bottom Molding	*WSF48SH26M-51-FGDM	Flame Generator Drive Motor (FP26-1A-THM-FGDM)
*WSF48SH26M-21-BRS	Base Rear Stretcher	*WSF48SH26M-52-RS	Reflector Spindle (FP26-1A-THM-RS)
*WSF48SH26M-22-D	Door	*WSF48SH26M-53-MPCBN	Main PCB (FP26-1A-THM-MPCBN)
*WSF48SH26M-23-DWI	Door Wood Insert	*WSF48SH26M-54-CPPCBN	Control Panel PCB (FP26-1A-THM-CPPCBN)
*WSF48SH26M-24-DGI	Door Glass Insert	*WSF48SH26M-55-LLPCBN	Logs Light PCB (FP26-1A-THM-LLPCBN)
*WSF48SH26M-25-RC	Rubber Clip	*WSF48SH26M-56-EBLPCBN	Ember Bed Light PCB (FP26-1A-THM-EBLPCBN)
*WSF48SH26M-26-FL	Floor Leveler	*WSF48SH26M-57-FLPCBN	Flame Light PCB (FP26-1A-THM-FLPCBN)
*WSF48SH26M-27-CL	Cam Lock	*WSF48SH26M-58-FIGF	Fireplace Insert Glass with Frame (FP26-1A-THM-FIGF)
*WSF48SH26M-28-CB	Cam Bolt	*WSF48SH26M-59-EBLN	Ember Bed/Logs (FP26-1A-THM-EBLN)
*WSF48SH26M-29-CC	Corner Connector	*WSF48SH26M-60-T	Thermostat (FP26-1A-THM-T)
*WSF48SH26M-30-1 1/2WS	#8 x 1-1/2" Wood Screw	*WSF48SH26M-CH	Complete Hardware
*WSF48SH26M-31-1S	#8 x 1" Screw	*WSF48SH26M-CFI	Complete Fireplace Insert (FP26-1A-THM)