

# CRAFT + MAIN®

## JASPYN COLLECTION

48" VANITY COMBO

SKU #6057874 | MODEL #JPGRVT4820D

SKU #6057879 | MODEL #JPGVT4820D

SKU #6057884 | MODEL #JPWVT4820D

### CUSTOMER SERVICE

U.S. Customers: 1-888-620-3667



Monday - Friday, 7:00 a.m. - 5:00 p.m., CT

[www.craftandmain.com](http://www.craftandmain.com)

[customerservice.us@fgi-industries.com](mailto:customerservice.us@fgi-industries.com)

### PARTS LIST

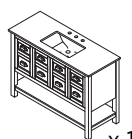
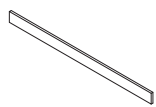
INCLUDED

<b>A VANITY</b>  x 1	<b>B BACKSPLASH</b>  x 1	<b>C HANDLE</b>  x 8	<b>D SCREW</b>  x 16
---	---	---	---

### TOOLS REQUIRED

NOT INCLUDED



Clean Rag

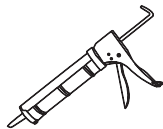

Silicone Caulk

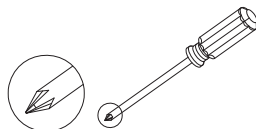

Phillips Head Screwdriver

**1**

## ATTACHING THE BACKSPLASH

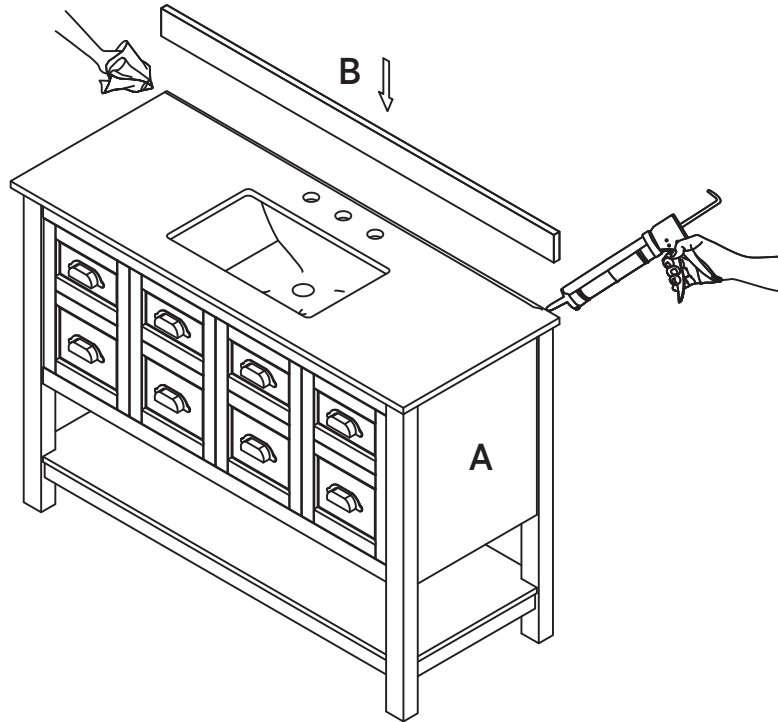

- To mount the backsplash (B) to the wall, apply a thin bead of silicone compound (not included) to the unpolished back side and bottom of the backsplash (B).
- Position the backsplash (B) as shown onto vanity top (A) and against the wall. Clean any excess silicone compound before allowing to dry.

## OPTIONAL

## CHANGING THE HARDWARE

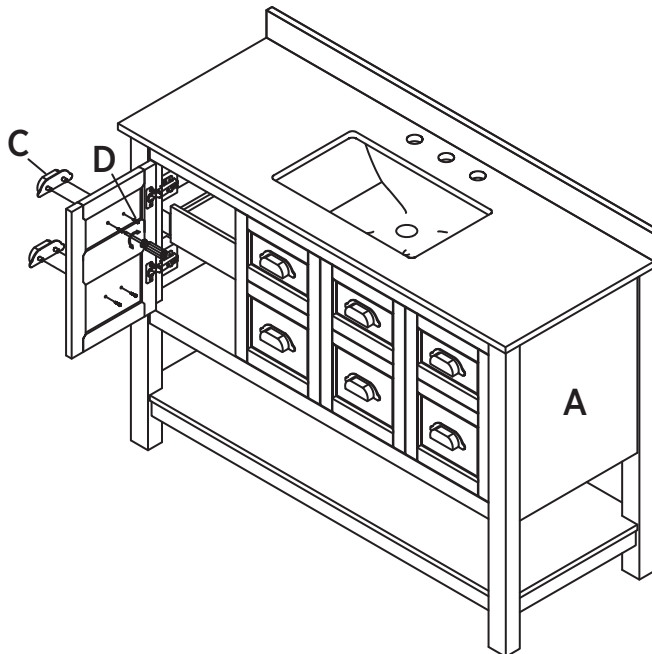

- This unit is shipped with hardware already attached. If desired, you can replace it with the optional finish hardware included.
- Remove and replace door and drawer handles (C) with Phillips head screwdriver and screws (D).

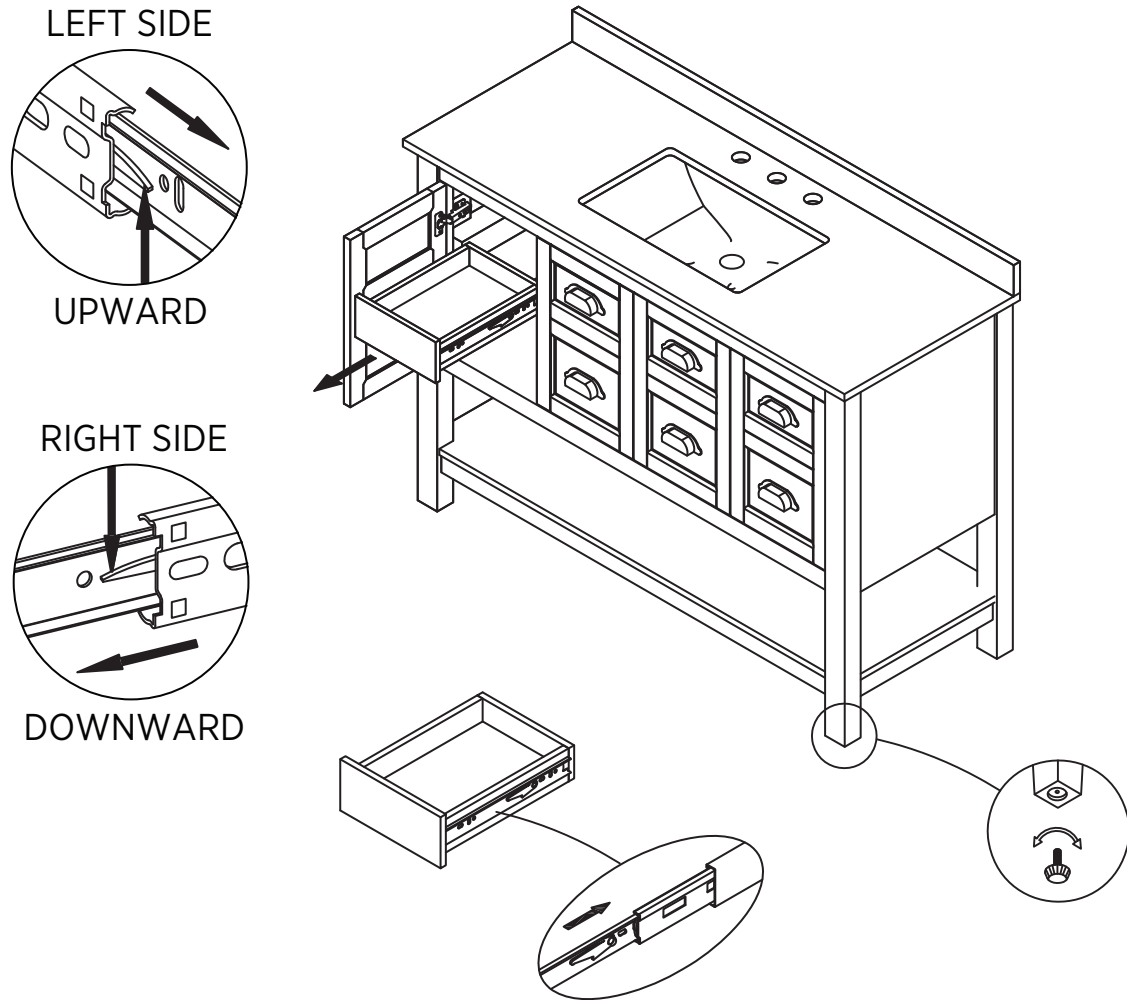
**OPTIONAL****REMOVING THE DRAWER & ADJUSTING THE LEG LEVELERS**

- Fully extend the drawer.
- Simultaneously pull the latch on the left-side drawer glide upward, and push the latch on the right-side drawer glide downward to release the lock.
- Pull the drawer out of the vanity (A).
- If the floor is uneven, causing the vanity (A) to wobble, determine which foot needs to be adjusted in height.
- Carefully tilt the vanity (A) either backwards or forwards to access the leg leveler. Turn it clockwise to make the leg shorter, or counterclockwise to make it longer.
- Repeat as needed with the other feet until the vanity (A) stands solidly on the floor.

# CRAFT + MAIN®

---

## WARRANTY REGISTRATION

To receive warranty coverage for your purchase, you must complete the warranty registration form found on our website within 30 days of purchase, or provide valid proof of purchase detailing the date and location of your purchase.

[www.craftandmain.com/warranty](http://www.craftandmain.com/warranty)

## CUSTOMER SERVICE

Your new CRAFT + MAIN® furniture is constructed using only the finest materials and captures the essence of timeless beauty and style.

Should you have any questions about your furniture, we would like to address the concern quickly. Our trained staff is ready to help you with quick, efficient service.

**CUSTOMER SERVICE:** 1-888-620-3667  
[customerservice.us@fgi-industries.com](mailto:customerservice.us@fgi-industries.com)  
[www.craftandmain.com](http://www.craftandmain.com)

## LIMITED WARRANTY

CRAFT + MAIN® products are covered by the FGI Industries, Ltd. 1 year limited warranty, which is as follows:

We warrant our products to be free from defects in material or workmanship for a period of 1 year from the date of delivery.

These warranties are made to the original purchaser and are limited to the repair or exchange of any parts which prove defective under normal use during the warranty period.

These warranties do not apply where products have been improperly stored or improperly installed, misused, abused, or modified in any way. They do not cover the costs of removing warranted material or the installation of replacement material.

These warranties are the sole warranties of FGI Industries, Ltd., and in lieu of all other warranties, express or implied, including any implied warranties of merchantability and fitness for a particular use. Labor charges for removal of or installation of warranted material as well as incidental or consequential damages are excluded. We do not assume for us any other liability in connection with the sale of our product.

## HOW TO KEEP YOUR FURNITURE LOOKING BEAUTIFUL

Quality wood furniture is a significant investment expected to last for generations. To maintain its beauty and help it last, wood furniture needs the right care. Your new CRAFT + MAIN® furniture is finished with two to three coats of lacquer for extra depth and long-lasting durability. The sheen, or gloss, of the finish ranges from high to low, depending on the piece or collection. The finish protects the wood and adds to its beauty. No finish is totally indestructible, but with regular care, the finish will last much longer, providing years of enjoyment to you.

To protect and care for your furniture, we suggest the following:

- Avoid placing your CRAFT + MAIN® furniture in direct sunlight, as sunlight causes fading.
- Clean up spills immediately. Use a blotting rather than a wiping action. Water left over a long period of time will cause white spots in the finish. Alcohol, perfume, after-shave and medications can cause severe finish damage.

## CLEANING AND POLISHING YOUR FURNITURE

We recommend dusting frequently with a clean, soft, dry, lint-free cloth. Clean the surface by rubbing in the direction of the grain. We recommend polishing your furniture approximately every six months, using a clean, soft, lint-free cloth and rubbing the polish in the direction of the grain.

## WHAT FURNITURE CARE PRODUCTS DO WE RECOMMEND?

We recommend polishes which contain detergents, emulsifiers and mineral oil. The detergents clean dirt from the furniture, the emulsifiers give it body to clean and last longer and the mineral oil is left behind as a barrier for dirt and moisture that could harm finishes. There's no grit to harm the finish, no wax to build up and no silicone to raise the sheen and act as a barrier for touch-up and refinishing.

## SINK CARE AND MAINTENANCE

Clean the surfaces with mild soap and warm water. Then dry with a soft cloth. Clean up spills immediately. Do not use products that contain lemon, vinegar or other acids. Using this type of cleaning process will cause the finish to dull.

## CLEANING GLASS MIRRORS

Ammonia or vinegar based cleaners can damage mirrors. We recommend a solution of 50% water and 50% isopropyl alcohol for mirror cleaning.