

DETAIL A
SCALE 2 : 1

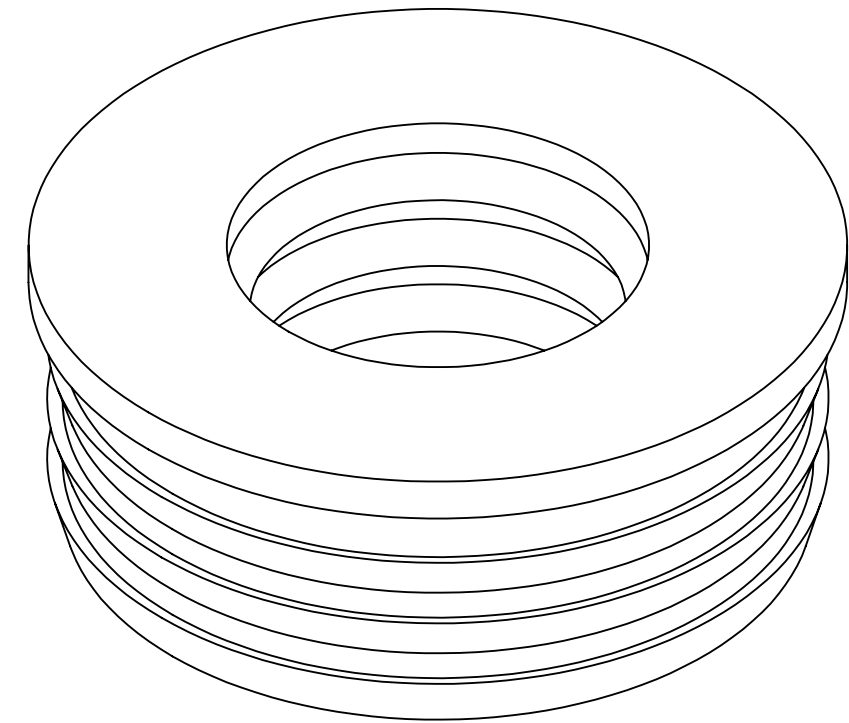

300 S. DAYTON ST.
DAVISON, MI 48423
PH: 810-653-9626
FAX: 810-654-2616

Part Weight	.65 lbs.
Min/Max Temp.	-30/140 Degrees F
Pressure Tested	4.3 PSI
Material	Flexible PVC 60 Duro Shore A
Installation Torque	
Conforms to ASTM	D5926
Box Quantity	
Clamps used	

TOLERANCES:
.X= Fractional ±
.XX= ±.060
.XXX= ±.032
ANG.= ±0.5°
UNLESS OTHERWISE SPECIFIED

DESCRIPTION:
Donut 3" Service Weight Cast
Iron x 2" Service Weight

33U-201

PROPRIETARY AND CONFIDENTIAL
THE INFORMATION CONTAINED IN THIS
DRAWING IS THE SOLE PROPERTY OF
FERNCO, INC. ANY REPRODUCTION IN
PART OR AS A WHOLE WITHOUT THE
WRITTEN PERMISSION OF FERNCO, INC.
IS PROHIBITED.

UNITS: INCHES	SIZE A	DESIGNER: D. Brady	SCALE not to scale
3RD ANGLE PROJECTION DO NOT SCALE DRAWING		CHECKER:	DATE: 9/3/2010
			SHEET 1 OF 1