

DETAIL A  
SCALE 2 : 1

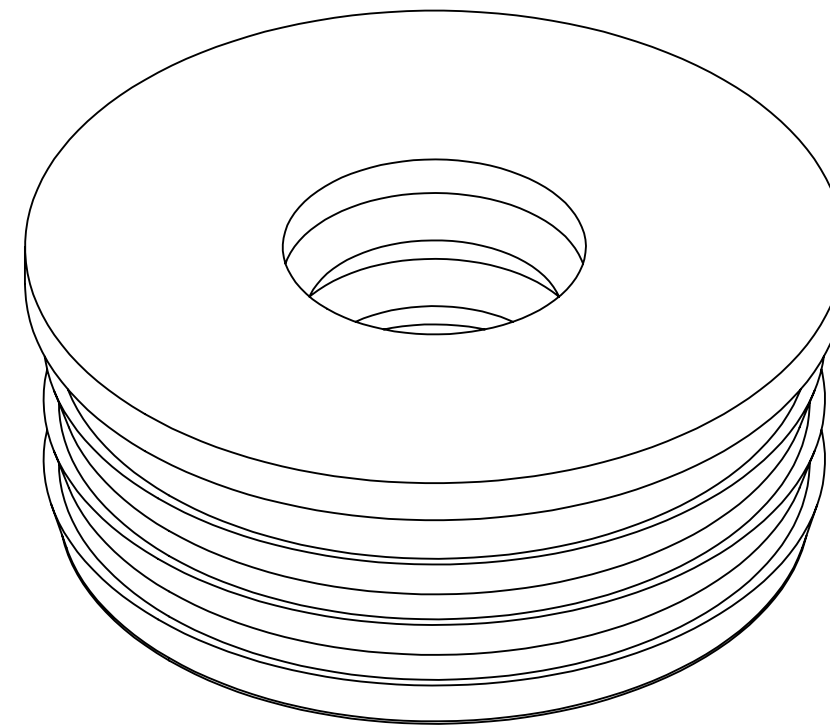

300 S. DAYTON ST.  
DAVISON, MI 48423  
PH: 810-653-9626  
FAX: 810-654-2616

Part Weight	1.06 lbs.
Min/Max Temp.	-30/140 Degrees F
Pressure Tested	4.3 PSI
Material	Flexible PVC 60 Duro Shore A
Installation Torque	
Conforms to ASTM	D5926
Box Quantity	
Clamps used	

TOLERANCES:  
.X= Fractional ±  
.XX= ±.060  
.XXX= ±.032  
ANG.= ±0.5°  
UNLESS OTHERWISE SPECIFIED

DESCRIPTION:  
Donut 3" Service Weight  
Cast Iron x 1 1/2" Copper

**33U-117**

**PROPRIETARY AND CONFIDENTIAL**  
THE INFORMATION CONTAINED IN THIS DRAWING IS THE SOLE PROPERTY OF FERNCO, INC. ANY REPRODUCTION IN PART OR AS A WHOLE WITHOUT THE WRITTEN PERMISSION OF FERNCO, INC. IS PROHIBITED.

UNITS: INCHES	SIZE <b>A</b>	DESIGNER: D. Brady	SCALE not to scale
3RD ANGLE PROJECTION DO NOT SCALE DRAWING		CHECKER:	DATE: 9/3/2010
			SHEET 1 OF 1