



300 S. DAYTON ST.  
 DAVISON, MI 48423  
 PH: 810-653-9626  
 FAX: 810-654-2616

150-305

DESCRIPTION:

Donut 4 x 3

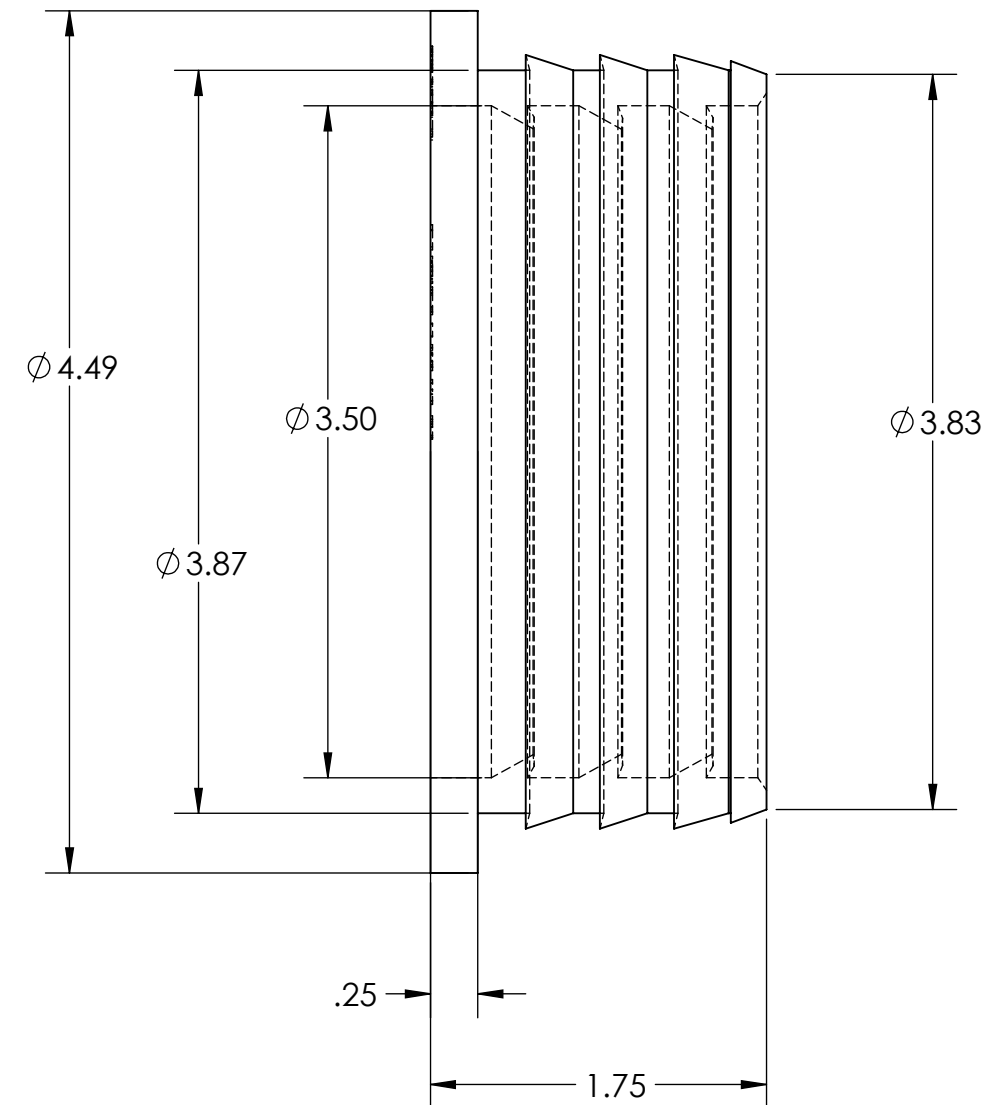
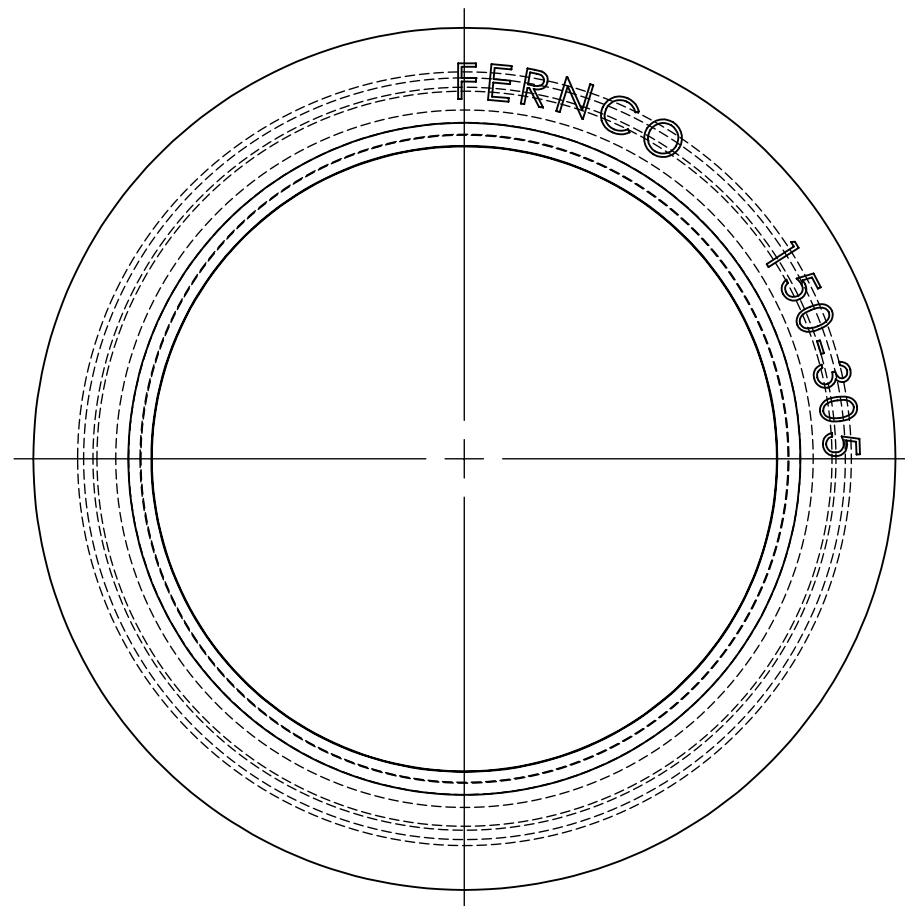

PROPRIETARY AND CONFIDENTIAL  
 THE INFORMATION CONTAINED IN THIS  
 DRAWING IS THE SOLE PROPERTY OF  
 FERNCO, INC. ANY REPRODUCTION IN  
 PART OR AS A WHOLE WITHOUT THE  
 WRITTEN PERMISSION OF FERNCO, INC.  
 IS PROHIBITED.

TOLERANCES:  
 Fractional  $\pm .125''$   
 .XX =  $\pm .03$   
 ANG. =  $\pm 5^\circ$   
 UNLESS OTHERWISE SPECIFIED

<i>Part Weight</i>		<i>Installation Torque</i>	
<i>Min \ Max Temp.</i>	-30/140 Degrees F	<i>Conforms to ASTM</i>	
<i>Pressure Tested</i>		<i>Clamps used</i>	
<i>Material</i>	Flexible PVC 60 Duro Shore A		

UNITS:	SIZE:
INCHES	<b>A</b>
3RD ANGLE PROJECTION	
DO NOT SCALE DRAWING	

DESIGNER:	DATE:
T. Oistad	4/13/2017
CHECKER:	

SCALE:
not to scale
SHEET 1 OF 1