

MASTERFORCE®

1/4" Impact Driver

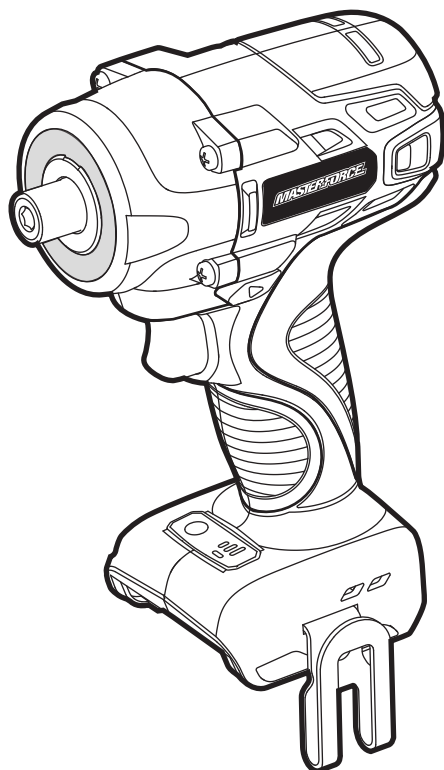

241-0435

OPERATOR'S MANUAL

⚠ CAUTION: To Reduce the Risk of Injury, User Must Read and Understand the Operator's Manual. Save These Instructions For Future Reference.



For questions / comments, technical assistance or repair parts –
Please Call Toll Free: 1-866-917-4374 (M-F 8:30am-5:00pm EST).

TABLE OF CONTENTS

Safety Symbols	Page 2
Safety Instructions	Page 3
Overview/Specifications	Page 7
Assembly	Page 8
Operation	Page 11
Maintenance	Page 12
Troubleshooting	Page 13
Warranty	Page 14

SAFETY SYMBOLS

Some of these following symbols may be used on this tool. Please study them and learn their meaning. Proper interpretation of these symbols will allow you to operate the tool better and more safely.

Symbol	Name	Designation / Explanation
V	Volts	Voltage
A	Amperes	Current
Hz	Hertz	Frequency (cycles per second)
W	Watts	Power
~	Alternating current	Type of current
—	Direct current	Type or characteristic of current
n_0	No-load speed	Rotational speed at no load
	Class II construction	Double insulated construction
.../min	Per minute	Revolutions, strokes, surface speed orbits, etc., per minute
	Wear safety goggles	<div style="border: 1px solid black; padding: 2px; display: inline-block;">  WARNING: </div> The operation of any power tool can result in foreign objects being thrown into your eyes, which can result in severe eye damage. Before beginning power tool operation, always wear safety goggles or safety glasses with side shields and a full-face shield when needed. We recommend a Wide Vision Safety Mask for use over eye-glasses or standard safety glasses with side shields. Always use eye protection which is marked to comply with ANSI Z87.1.

 WARNING: To ensure safety and reliability, all repairs should be performed by a qualified service technician.

SAFETY INSTRUCTIONS

The purpose of safety symbols is to attract your attention to possible dangers. The safety symbols, and the explanations with them, deserve your careful attention and understanding. The symbol warnings do not, by themselves, eliminate any danger. The instructions and warnings they give are no substitutes for proper accident prevention measures.

 **WARNING:** Be sure to read and understand all safety instructions in this manual, including all safety alert symbols such as “DANGER”, “WARNING” and “CAUTION” before using this tool. Failure to following all instructions listed below may result in electric shock, fire, and/or serious personal injury.

SYMBOL MEANING

 **SAFETY ALERT SYMBOL:** Indicates DANGER, WARNING, OR CAUTION. May be used in conjunction with other symbols or pictographs.

 **DANGER:** Indicates an imminently hazardous situation, which, if not avoided, will result in death or serious injury.

 **WARNING:** Indicates a potentially hazardous situation, which, if not avoided, could result in death or serious injury.

 **CAUTION:** Indicates a potentially hazardous situation, which, if not avoided, could result in minor or moderate injury.

NOTICE: (Without Safety Alert Symbol) Indicates a situation that may result in property damage.

SAVE THESE INSTRUCTIONS!

SAFETY INSTRUCTIONS

GENERAL POWER TOOL SAFETY WARNINGS

 **WARNING:** Read all safety warnings, instruction, illustrations and specifications provided with this power tool.

Failure to follow all instructions listed below may result in electric shock, fire and/or serious injury.

Save all warnings and instructions for future reference.

The term “power tool” in the warnings refers to your mains-operated (corded) power tool or battery-operated (cordless) power tool.

WORK AREA SAFETY

- a) Keep work area clean and well lit. Cluttered or dark areas invite accidents.
- b) Do not operate power tools in explosive atmospheres, such as in the presence of flammable liquids, gases or dust. Power tools create sparks which may ignite the dust or fumes.
- c) Keep children and bystanders away while operating a power tool. Distractions can cause you to lose control.

ELECTRICAL SAFETY

- a) Power tool plugs must match the outlet. Never modify the plug in any way. Do not use any adapter plugs with earthed (grounded) power tools. Unmodified plugs and matching outlets will reduce risk of electric shock.
- b) Avoid body contact with earthed or grounded surfaces, such as pipes, radiators, ranges and refrigerators. There is an increased risk of electric shock if your body is earthed or grounded.
- c) Do not expose power tools to rain or wet conditions. Water entering a power tool will increase the risk of electric shock.

- d) Do not abuse the cord. Never use the cord for carrying, pulling or unplugging the power tool. Keep cord away from heat, oil, sharp edges or moving parts. Damaged or entangled cords increase the risk of electric shock.
- e) When operating a power tool outdoors, use an extension cord suitable for outdoor use. Use of a cord suitable for outdoor use reduces the risk of electric shock.
- f) If operating a power tool in a damp location is unavoidable, use a ground fault circuit interrupter (GFCI) protected supply. Use of an GFCI reduces the risk of electric shock.

PERSONAL SAFETY

- a) Stay alert, watch what you are doing and use common sense when operating a power tool. Do not use a power tool while you are tired or under the influence of drugs, alcohol or medication. A moment of inattention while operating power tools may result in serious personal injury.
- b) Use personal protective equipment. Always wear eye protection. Protective equipment such as a dust mask, non-skid safety shoes, hard hat or hearing protection used for appropriate conditions will reduce personal injuries.
- c) Prevent unintentional starting. Ensure the switch is in the off-position before connecting to power source and/or battery pack, picking up or carrying the tool. Carrying power tools with your finger on the switch or energizing power tools that have the switch on invites accidents.
- d) Remove any adjusting key or wrench before turning the power tool on. A wrench or a key left attached to a rotating part of the power tool may result in personal injury.
- e) Do not overreach. Keep proper footing and balance at all times. This enables better control of the power tool in unexpected situations.
- f) Dress properly. Do not wear loose clothing or jewelry. Keep your hair and

SAFETY INSTRUCTIONS

clothing away from moving parts. Loose clothes, jewelry or long hair can be caught in moving parts.

- g) If devices are provided for the connection of dust extraction and collection facilities, ensure these are connected and properly used. Use of dust collection can reduce dust-related hazards.**
- h) Do not let familiarity gained from frequent use of tools allow you to become complacent and ignore tool safety principles. A careless action can cause severe injury within a fraction of a second.**

POWER TOOL USE AND CARE

- a) Do not force the power tool. Use the correct power tool for your application. The correct power tool will do the job better and safer at the rate for which it was designed.**
- b) Do not use the power tool if the switch does not turn it on and off. Any power tool that cannot be controlled with the switch is dangerous and must be repaired.**
- c) Disconnect the plug from the power source and/or remove the battery pack, if detachable, from the power tool before making any adjustments, changing accessories, or storing power tools. Such preventive safety measures reduce the risk of starting the power tool accidentally.**
- d) Store idle power tools out of the reach of children and do not allow persons unfamiliar with the power tool or these instructions to operate the power tool. Power tools are dangerous in the hands of untrained users.**
- e) Maintain power tools and accessories. Check for misalignment or binding of moving parts, breakage of parts and any other condition that may affect the power tool's operation. If damaged, have the power tool repaired before use. Many accidents are caused by poorly maintained power tools.**
- f) Keep cutting tools sharp and clean. Properly maintained cutting tools with sharp cutting edges are less likely to bind and are**

easier to control.

- g) Use the power tool, accessories and tool bits etc. in accordance with these instructions, taking into account the working conditions and the work to be performed. Use of the power tool for operations different from those intended could result in a hazardous situation.**
- h) Keep handles and grasping surfaces dry, clean and free from oil and grease. Slippery handles and grasping surfaces do not allow for safe handling and control of the tool in unexpected situations.**

SERVICE

- a) Have your power tool serviced by a qualified repair person using only identical replacement parts. This will ensure that the safety of the power tool is maintained.**

SPECIFIC SAFETY WARNINGS

- a) Hold power tools by insulated gripping surfaces when performing an operation where the cutting tool may contact hidden wiring. Contact with a "live" wire will make exposed metal parts of the tool live and shock the operator.**
- b) Take protective measures when dust can develop during working that is harmful to one's health, combustible or explosive. Example: Some dusts are regarded as carcinogenic. Wear a dust mask and work with dust/chip extraction when connectable.**
- c) Secure the workpiece. A workpiece clamped with clamping devices or in a vice is held more secure than by hand.**
- d) To reduce the risk of electric shock or damage to the charger and battery, use only the batteries and charger listed.**

SAFETY INSTRUCTIONS

Battery pack	Charger
252-8024	252-8025
252-8029	252-8036
252-8030	252-8037
252-8031	252-8044
252-8032	
252-8033	
252-8034	
252-8035	

 **WARNING:** Some dust created by power sanding, sawing, grinding, drilling and other construction activities contains chemicals known to the state of California to cause cancer, birth defects or other reproductive harm. Some examples of

these chemicals are:

- Lead from lead-based paints
- Crystalline silica from bricks and cement and other masonry products, and
- Arsenic and chromium from chemically-treated lumber.

Your risk from these exposures varies, depending on how often you do this type of work. To reduce your exposure to these chemicals: work in a well ventilated area, and work with approved safety equipment, such as those dust masks that are specially designed to filter out microscopic particles.

OVERVIEW

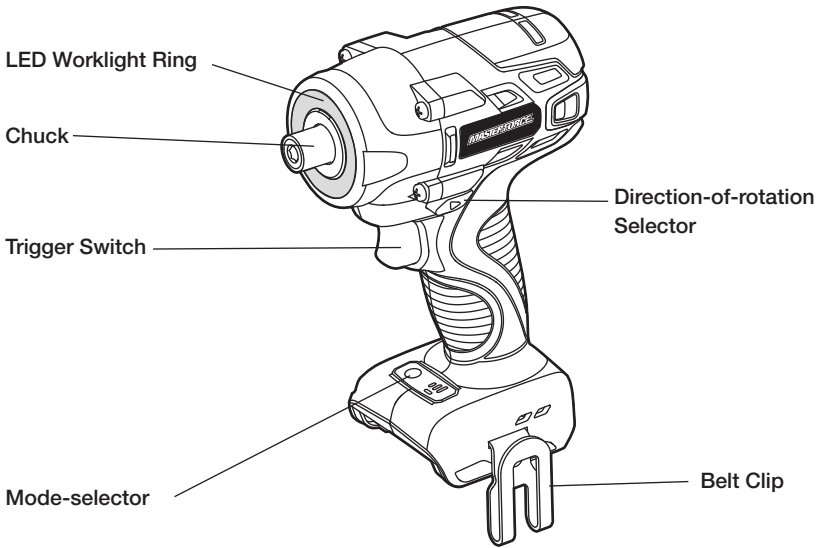

SPECIFICATIONS

No-load Speed	I: 0-1,100 RPM
	II: 0-1,900 RPM
	III: 0-2,800 RPM
Impact Rate	I: 0-1,200 BPM
	II: 0-2,350 BPM
	III: 0-3,300 BPM
Torque	I: 770 in.lb
	II: 1,240 in.lb
	III: 1,700 in.lb
Driver	1/4" Hex
Weight	2 lb. 14 oz (1.3 kg)

ASSEMBLY

CONTENTS

Cordless impact driver, bit holder, belt clip, bit and instruction manual.

UNPACKING

1. Carefully remove the tool and any accessories from the carton. Make sure that all items listed in the packing list are included.
2. Inspect the tool carefully to make sure that no breakage or damage occurred during shipping.
3. Do not discard the packing material until you have carefully inspected and satisfactorily operated the blower.

WARNING: If any part is broken or missing, **DO NOT** attach the battery pack or operate the tool until the broken or missing part is replaced. Failure to do so could result in possible serious injury.

WARNING: Do not attempt to modify this tool or create accessories not recommended for use with this tool. Any such alteration or modification is misuse and could result in a hazardous condition leading to possible serious injury.

WARNING: Your tool should never be connected to the battery pack when you are assembling parts, making adjustments, installing or removing bits, cleaning, or when it is not in use. Disconnecting the tool will prevent accidental starting, which could cause serious personal injury.

ASSEMBLY

TO ATTACH BATTERY PACK (FIG. 1)

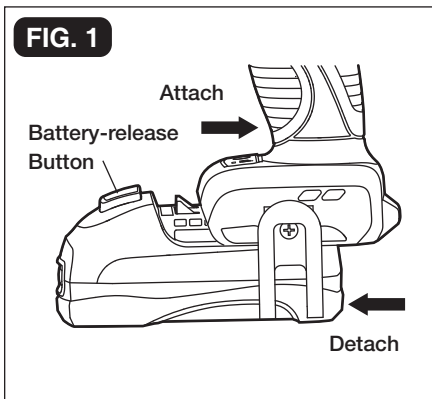

1. Make sure that the tool is switched off.
2. Align the raised rib on the battery pack with the grooves on the bottom of the impact driver, and then slide the battery pack onto the tool.

NOTICE: Make sure that the latch on the battery pack snaps into place and the battery pack is secured to the tool before operation.

TO DETACH BATTERY PACK (FIG. 1)

1. Make sure that the tool is switched off.
2. Depress the battery-release button located on the front of the battery pack to release the battery pack.
3. Pull the battery pack out and remove it from the tool.

ASSEMBLY

TRIGGER SWITCH (FIG.2)

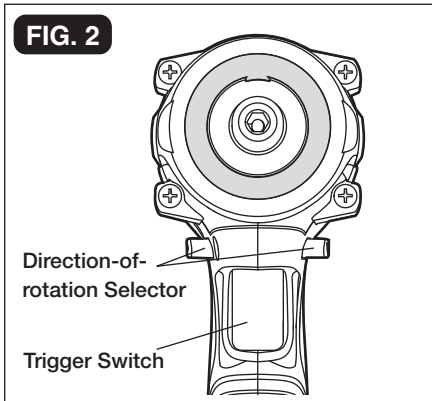

To turn the impact driver on, depress the trigger switch.

To turn it off, release the trigger switch.

VARIABLE SPEED

The variable-speed trigger switch delivers higher speed with increased trigger pressure and lower speed with decreased trigger pressure.

DIRECTION-OF-ROTATION SELECTOR (FORWARD/CENTER-LOCK/REVERSE) (FIG.3)

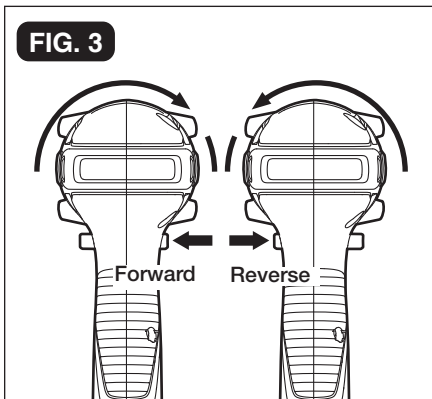

The direction of rotation is reversible and is controlled by a selector located above the trigger switch. With the impact driver held in normal operating position: position the direction-of-rotation selector to the left of the tool for forward rotation; position the direction-of-rotation selector to the right of the tool for reverse rotation. Setting the switch in the OFF (center-lock) position helps to reduce the possibility of accidental starting when not in use.

NOTICE: To prevent gear damage, always allow the impact driver to come to a complete stop before changing the direction of rotation.

NOTICE: The impact driver will not run unless the direction of the rotation selector is engaged fully to the left or right.

MODE SELECTOR (FIG.4)

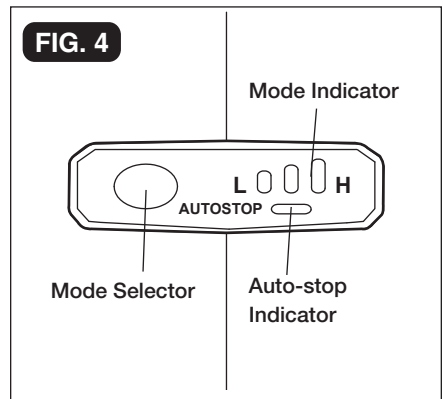

NOTICE: The impact driver is designed with 3-speed and auto-stop functions; these functions are available only when the tool is operating in forward rotation.

NOTICE: The mode can only be changed when the mode-indicator light is on. The mode-indicator light will be off automatically in about one minute.

1. Attach the battery pack to the impact driver.

ASSEMBLY

2. Position the direction-of-rotation selector to the left of the tool for forward rotation, and press the trigger switch to turn on the mode-indicator light.
3. Press the mode selector to change the speed: press once for low, press twice for medium, and press a third time for high.
4. To make the Auto-stop function available, press and hold the mode selector for three seconds: the auto-stop indicator will shine. When a bolt/nut is sufficiently tightened, the tool will automatically stop the impact and rotation after approximately one second.
5. To turn off the auto-stop function, press and hold the mode selector for three seconds again. The auto-stop indicator is will turn off.

ELECTRIC BRAKE

The impact driver is equipped with an electric brake. When the trigger switch is released, the electric brake engages automatically to quickly stop the rotation.

LED WORKLIGHT RING (FIG.5)

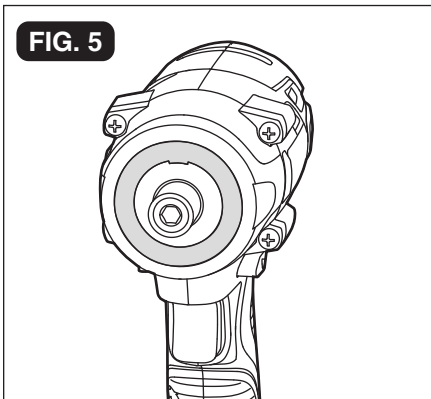

The LED worklight rings, located around the shaft of the impact driver, will illuminate when the trigger switch is depressed. This provides additional light on the surface of the workpiece for operation in lower-light areas. The light will automatically turn off within 10 seconds after the trigger is released.

INSTALLING THE BELT CLIP (FIG.6)

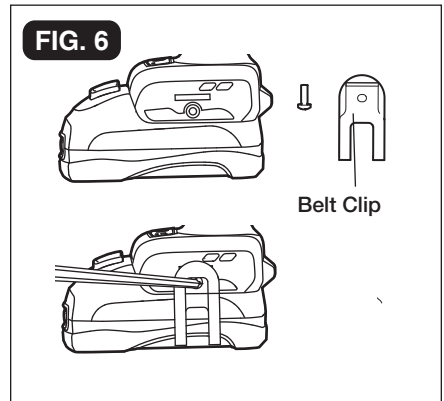

1. Remove the battery from the tool.
2. Align the rib of the belt clip with the hole on the base of the driver.
3. Insert the screw and securely tighten the screw with a screwdriver.

REMOVING THE BELT CLIP

1. Remove the battery from the tool.
2. Use a screwdriver to loosen the screw that attaches the belt clip to the driver.
3. Remove the screw and the belt clip.

OPERATION

TO INSTALL THE BIT HOLDER (FIG.7):

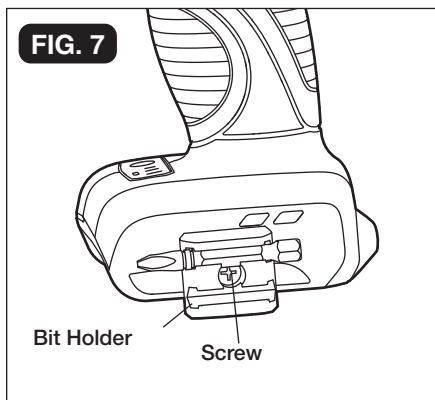

1. Remove the battery from the tool.
2. Align the rib of the bit holder with the hole in the base of the impact driver.
3. Insert the screw (included) and securely tighten the screw with a screwdriver (not included). The bit holder can be positioned on either side of the tool.

To remove the bit holder:

1. Remove the battery from the tool.
2. Use a screwdriver to loosen the screw that attaches the bit holder to the impact driver.
3. Remove the screw and the bit holder.

INSTALLING BITS (FIG.8)

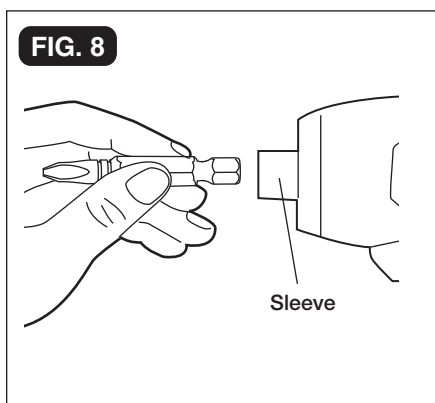

1. Lock the trigger switch on the impact driver by placing the direction-of-rotation selector in the center position.
2. Insert the bit into the chuck. You will hear a “click” to indicate that the bit is securely installed in place.
3. Pull on the bit to check if it installed securely.

REMOVING BITS

1. Lock the trigger switch on the impact driver by placing the direction-of-rotation selector in the center position.
2. Pull the sleeve towards the front of the tool.
3. The bit should pop out from the chuck automatically, if not, simply pull out the bit.

TIGHTENING AND LOOSENING SCREWS

1. Install the correct bit.
2. Apply just enough pressure to keep the bit engaged on the screw.
3. Apply minimal pressure to the trigger switch initially. Increase the speed only when full control can be maintained.

TIGHTENING AND LOOSENING NUTS AND BOLTS

Variable speed control must be used with caution for driving nuts and bolts with socket set attachments. The best technique is to start slowly, increasing speed as the nut or bolt runs down. Set the nut or bolt snugly by slowing the tool to a stop. If this procedure is not followed, the tool will have a tendency to torque or twist in your hands when the nut or bolt seats.

MAINTENANCE

 **WARNING:** Always wear safety goggles or safety glasses with side shields during power tool operations, or when blowing dust. If operation is dusty, also wear a dust mask.

 **WARNING:** Do not at any time allow brake fluids, gasoline, petroleum-based products, penetrating oils, etc. to come in contact with plastic parts. Chemicals can damage, weaken or destroy plastic, which may result in serious personal injury.

MAINTENANCE

The tool may be cleaned most effectively with compressed dry air. Always wear safety goggles when cleaning tools with compressed air.

Avoid using solvents when cleaning plastic parts. Most plastics are susceptible to damage from various types of commercial solvents and may be damaged by their use. Use a clean cloth to remove dirt, dust, oil, grease, etc.

BEFORE EACH USE

1. Check for damaged, missing, or worn parts.
2. Check for loose screws, misalignment or binding of moving parts, or any other condition that may affect the operation.
3. If abnormal vibration or noise occurs, turn the tool off immediately and have the problem corrected before further use.

TROUBLESHOOTING

PROBLEM	CAUSE	SOLUTION
The impact driver does not work.	The battery pack is depleted.	Charge the battery pack.
	The battery pack or impact driver is too hot.	Turn off the impact driver and allow the impact driver and battery pack to cool.



1/4" Impact Driver WARRANTY

90-DAY MONEY BACK GUARANTEE:

This MASTERFORCE® brand power tool carries our 90-DAY Money Back Guarantee. If you are not completely satisfied with your MASTERFORCE® brand power tool for any reason within ninety (90) days from the date of purchase, return the tool with your original receipt to any MENARDS® retail store, and we will provide you a refund – no questions asked.

3-YEAR LIMITED WARRANTY:

This MASTERFORCE® brand power tool carries our famous No Hassle 3-Year Limited Warranty to the original purchaser. If, during normal use, this MASTERFORCE® power tool breaks or fails due to a defect in material or workmanship within three (3) years from the date of original purchase, simply bring this tool with the original sales receipt back to your nearest MENARDS® retail store. At its discretion, MASTERFORCE® agrees to have the tool or any defective part(s) repaired or replaced with the same or similar MASTERFORCE® product or part free of charge, within the stated warranty period, when returned by the original purchaser with original sales receipt. Notwithstanding the foregoing, this limited warranty does not cover any damage that has resulted from abuse or misuse of the Merchandise. This warranty: (1) excludes expendable parts including but not limited to blades, brushes, belts, bits, light bulbs, and/or batteries; (2) shall be void if this tool is used for commercial and/or rental purposes; and (3) does not cover any losses, injuries to persons/property or costs. This warranty does give you specific legal rights and you may have other rights, which vary from state to state. Be careful, tools are dangerous if improperly used or maintained. Seller's employees are not qualified to advise you on the use of this Merchandise. Any oral representation(s) made will not be binding on seller or its employees. The rights under this limited warranty are to the original purchaser of the Merchandise and may not be transferred to any subsequent owner. This limited warranty is in lieu of all warranties, expressed or implied including warranties or merchantability and fitness for a particular purpose. Seller shall not be liable for any special, incidental, or consequential damages. The sole exclusive remedy against the seller will be for the replacement of any defects as provided herein, as long as the seller is willing or able to replace this product or is willing to refund the purchase price as provided above. For insurance purposes, seller is not allowed to demonstrate any of these power tools for you.

For questions / comments, technical assistance or repair parts –

Please call toll free: 1-866-917-4374 (M-F 8:30am – 5:00pm EST).

**SAVE YOUR RECEIPTS
THIS WARRANTY IS VOID WITHOUT THEM**

MASTER★FORCE[®]

MENARDS[®]

MASTERFORCE[®]

Brushless 1/2" Hammer Drill

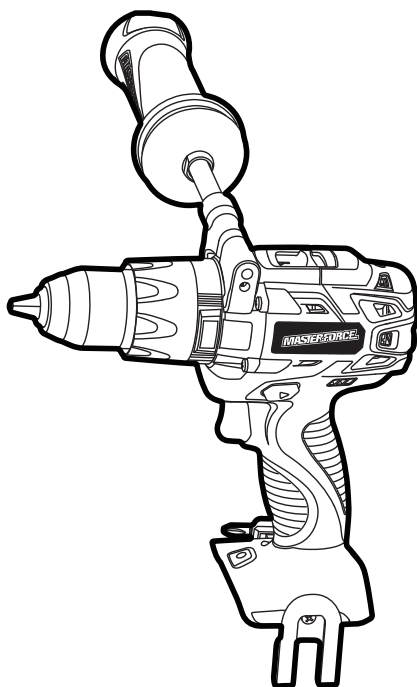

241-0464

OPERATOR'S MANUAL

⚠ CAUTION: To Reduce The Risk Of Injury, User Must Read And Understand Operator's Manual. Save These Instructions For Future Reference.



For questions / comments, technical assistance or repair parts –
Please Call Toll Free: 1-866-917-4374 (M-F 8:30am-5:00pm EST).

TABLE OF CONTENTS

Safety Symbols	Page 2
Safety Instructions	Page 3
Overview/Specifications	Page 7
Assembly	Page 8
Operation	Page 12
Maintenance	Page 15
Troubleshooting	Page 16
Warranty	Page 18

SAFETY SYMBOLS

Some of these following symbols may be used on this tool. Please study them and learn their meaning. Proper interpretation of these symbols will allow you to operate the tool better and more safely.

Symbol	Name	Designation / Explanation
V	Volts	Voltage
A	Amperes	Current
Hz	Hertz	Frequency (cycles per second)
W	Watts	Power
~	Alternating current	Type of current
—	Direct current	Type or characteristic of current
n _o	No-load speed	Rotational speed at no load
lbs	Pounds	Weight
	Class II construction	Double insulated construction
.../min	Per minute	Revolutions, strokes, surface speed orbits, etc., per minute
	Wear safety goggles	<div style="border: 1px solid black; padding: 5px;">  WARNING: The operation of any power tool can result in foreign objects being thrown into your eyes, which can result in severe eye damage. Before beginning power tool operation, always wear safety goggles or safety glasses with side shields and a full-face shield when needed. We recommend a Wide Vision Safety Mask for use over eye-glasses or standard safety glasses with side shields. Always use eye protection which is marked to comply with ANSI Z87.1. </div>

 **WARNING:** To ensure safety and reliability, all repairs should be performed by a qualified service technician.

SAFETY INSTRUCTIONS

The purpose of safety symbols is to attract your attention to possible dangers. The safety symbols and the explanations with them deserve your careful attention and understanding. The symbol warnings do not, by themselves, eliminate any danger. The instructions and warnings they give are not substitutes for proper accident prevention measures.

 **WARNING:** Be sure to read and understand all safety instructions in this manual, including all safety alert symbols such as “DANGER,” “WARNING,” and “CAUTION” before using this tool. Failure to follow all instructions listed below may result in electric shock, fire, and/or serious personal injury.

SYMBOL MEANING



SAFETY ALERT SYMBOL: Indicates DANGER, WARNING, OR CAUTION. May be used in conjunction with other symbols or pictographs.



DANGER: Indicates an imminently hazardous situation, which, if not avoided, will result in death or serious injury.



WARNING: Indicates a potentially hazardous situation, which, if not avoided, could result in death or serious injury.



CAUTION: Indicates a potentially hazardous situation, which, if not avoided, could result in minor or moderate injury.

NOTICE: (Without Safety Alert Symbol) Indicates a situation that may result in property damage.

SAVE THESE INSTRUCTIONS!

SAFETY INSTRUCTIONS

GENERAL POWER TOOL SAFETY WARNINGS

 **WARNING:** Read all safety warnings and all instructions. Failure to follow the warnings and instructions may result in electric shock, fire and/or serious injury.

Save all warnings and instructions for future reference.

The term “power tool” in the warnings refers to your mains-operated (corded) power tool or battery-operated (cordless) power tool.

WORK AREA SAFETY

1. Keep work area clean and well lit. Cluttered and dark areas invite accidents.
2. Do not operate power tools in explosive atmospheres, such as in the presence of flammable liquids, gases or dust. Power tools create sparks which may ignite the dust or fumes.
3. Keep children and bystanders away while operating a power tool. Distractions can cause you to lose control

ELECTRICAL SAFETY

1. Power tool plugs must match the outlet. Never modify the plug in any way. Do not use any adapter plugs with earthed (grounded) power tools. Unmodified plugs and matching outlets will reduce risk of electric shock.
2. Avoid body contact with earthed or grounded surfaces, such as pipes, radiators, ranges and refrigerators. There is an increased risk of electric shock if your body is earthed or grounded.
3. Do not expose power tools to rain or wet conditions. Water entering a power tool will increase the risk of electric shock.
4. Do not abuse the cord. Never use the cord for carrying, pulling or unplugging the power tool. Keep cord away from heat, oil, sharp edges or moving parts. Damaged or entangled cords increase the risk of electric shock.

5. When operating a power tool outdoors, use an extension cord suitable for outdoor use. Use of a cord suitable for outdoor use reduces the risk of electric shock.
6. If operating a power tool in a damp location is unavoidable, use a ground-fault circuit interrupter (GFCI) protected supply. Use of a GFCI reduces the risk of electric shock.

PERSONAL SAFETY

1. Stay alert, watch what you are doing and use common sense when operating a power tool. Do not use a power tool while you are tired or under the influence of drugs, alcohol or medication. A moment of inattention while operating power tools may result in serious personal injury.
2. Use personal protective equipment. Always wear eye protection. Protective equipment such as dust mask, non-skid safety shoes, hard hat, or hearing protection used for appropriate conditions will reduce personal injuries.
3. Prevent unintentional starting. Ensure the switch is in the off-position before connecting to power source and/or battery pack, picking up or carrying the tool. Carrying power tools with your finger on the switch or energising power tools that have the switch on invites accidents.
4. Remove any adjusting key or wrench before turning the power tool on. A wrench or a key left attached to a rotating part of the power tool may result in personal injury.
5. Do not overreach. Keep proper footing and balance at all times. This enables better control of the power tool in unexpected situations.
6. Dress properly. Do not wear loose clothing or jewellery. Keep your hair, clothing and gloves away from moving parts. Loose clothes, jewellery or long hair can be caught in moving parts.
7. If devices are provided for the connection of dust extraction and collection facilities, ensure that these are connected and properly used. Use of these devices can reduce dust-related hazards.

SAFETY INSTRUCTIONS

POWER TOOL USE AND CARE

1. Do not force the power tool. Use the correct power tool for your application. The correct power tool will do the job better and more safely at the rate for which it was designed.
2. Do not use the power tool if the switch does not turn it on and off. Any power tool that cannot be controlled with the switch is dangerous and must be repaired.
3. Disconnect the plug from the power source and/or the battery pack from the power tool before making any adjustments, changing accessories, or storing power tools. Such preventive safety measures reduce the risk of starting the power tool accidentally.
4. Store idle power tools out of the reach of children and do not allow persons unfamiliar with the power tool or these instructions to operate the power tool. Power tools are dangerous in the hands of untrained users.
5. Maintain power tools. Check for misalignment or binding of moving parts, breakage of parts and any other condition that may affect the power tool's operation. If damaged, have the power tool repaired before use. Many accidents are caused by poorly maintained power tools.
6. Keep cutting tools sharp and clean. Properly maintained cutting tools with sharp cutting edges are less likely to bind and are easier to control.
7. Use the power tool, accessories, tool bits, etc. in accordance with these instructions, taking into account the working conditions and the work to be performed. Use of the power tool for operations different from those intended could result in a hazardous situation.

BATTERY TOOL USE AND CARE

1. Recharge only with the charger specified by the manufacturer. A charger that is suitable for one type of battery pack may create a risk of fire when used with another battery pack.

2. Use power tools only with specifically designated battery packs. Use of any other battery packs may create a risk of injury and fire.
3. When battery pack is not in use, keep it away from other metal objects, like paper clips, coins, keys, nails, screws or other small metal objects, that can make a connection from one terminal to another. Shorting the battery terminals together may cause burns or a fire.
4. Under abusive conditions, liquid may be ejected from the battery; avoid contact. If contact accidentally occurs, flush with water. If liquid contact eyes, additionally seek medical help. Liquid ejected from the battery may cause irritation or burns.

SERVICE

1. Have your power tool serviced by a qualified repair person using only identical replacement parts. This will ensure that the safety of the power tool is maintained.

SPECIFIC SAFETY RULES FOR HAMMER DRILLS

1. Use only with battery and charger listed below.

Battery pack	Charger
252-8024	252-8025
252-8029	252-8036
252-8030	252-8037
252-8031	252-8044
252-8032	
252-8033	
252-8034	
252-8035	

2. Wear ear protectors when impact drilling. Exposure to noise can cause hearing loss.
3. Use auxiliary handle(s), if supplied with the tool. Loss of control can cause personal injury.

SAFETY INSTRUCTIONS

4. **Hold power tool by insulated gripping surfaces, when performing an operation where the cutting accessory may contact hidden wiring.** Cutting accessory contacting a “live” wire may make exposed metal parts of the power tool “live” and could give the operator an electric shock.
5. **Use clamps or another practical way to secure and support the workpiece to a stable platform.** Holding the work by your hand or against the body leaves it unstable and may lead to loss of control.
6. **Do not drill, fasten or break into existing walls or other blind areas where electrical wiring may exist.** If this situation is unavoidable, disconnect all fuses or circuit breakers feeding this worksite.
7. **Always wear safety goggles or eye protection when using this tool.**
8. **Use thick cushioned gloves and limit the exposure time by taking frequent rest periods.** Vibration caused by hammer-drill action may be harmful to your hands and arms.
9. **Secure the material being fastened. Never hold it in your hand or across your legs.** Unstable support can cause loss of control and injury.
10. **Avoid accidental starting. Be sure the forward/reverse switch is in the off position before inserting battery pack.** Carrying appliances with your finger on the switch or inserting the battery pack into an appliance with the switch on invites accidents.
11. **Remove battery pack before changing accessories.** Accidental starting may occur because battery appliances with a battery inserted are in the operative condition.
12. **Do not use dull or damaged bits and accessories.** When installing an accessory, insert the shank of the bit well within the chuck. Be sure the chuck has locked onto the bit correctly.

 **WARNING:** Some dust created by power sanding, sawing, grinding, drilling and other construction activities contains chemicals known to the state of California to cause cancer, birth defects or other reproductive harm. Some examples of these chemicals are:

- Lead from lead-based paints
- Crystalline silica from bricks and cement and other masonry products, and
- Arsenic and chromium from chemically-treated lumber.

Your risk from these exposures varies, depending on how often you do this type of work. To reduce your exposure to these chemical: work in a well ventilated area, and work with approved safety equipment, such as those dust masks that are specially designed to filter out microscopic particles.

OVERVIEW

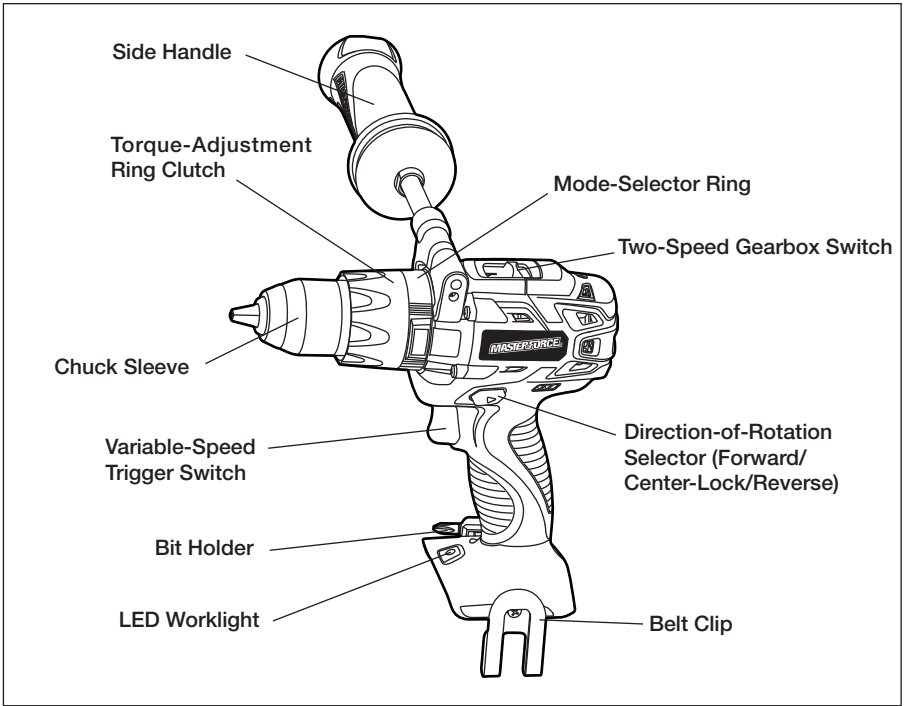

SPECIFICATIONS

No-load Speed	0-500/ 0-1,850 RPM
Impact Rate	0-6,500/ 0-24,050 BPM
Torque	700 in.lb.
Chuck Size	1/2 in. (13mm)
Tool Weight (without battery)	3 lb. (1.36kg)

ASSEMBLY

CONTENTS

⚠ WARNING: If any part is broken or missing, **DO NOT** attempt to plug in the power cord or operate the tool until the broken or missing part is replaced. Failure to do so could result in possible serious injury.

⚠ WARNING: Do not attempt to modify this tool or create accessories not recommended for use with this tool. Any such alteration or modification is misuse and could result in a hazardous condition leading to possible serious injury.

⚠ WARNING: Your tool should never be connected to the power source when you are assembling parts, making adjustments, installing or removing blades, cleaning, or when it is not in use. Disconnecting the tool will prevent accidental starting, which could cause serious personal injury.

Brushless hammer drill, belt clip, bit holder, bit, side handle and instruction manual.

UNPACKING

1. Carefully remove the tool and any accessories from the carton. Make sure that all items listed in the packing list are included.
2. Inspect the tool carefully to make sure that no breakage or damage occurred during shipping.
3. Do not discard the packing material until you have carefully inspected and satisfactorily operated the tool.

ASSEMBLY

TO ATTACH BATTERY PACK (FIG. 1)

1. Lock the trigger switch on the hammer drill by placing the direction-of-rotation selector in the center position.
2. Align the ribs on the battery pack with the grooves of the hammer drill, and then attach the battery pack.

NOTICE: Make sure that the latch on the battery pack snaps into place and the battery pack is secured to the hammer drill before operation.

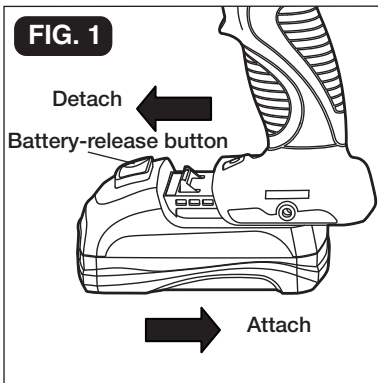

TO DETACH BATTERY PACK (FIG. 1)

1. Lock the trigger switch on the hammer drill by placing the direction-of-rotation selector in the center position.
2. Depress the battery-release button located on the battery pack to release the battery pack.
3. Pull the battery pack out and remove it from the tool.

INSTALLING BITS (FIG. 2)

WARNING: Disconnect the battery pack from tool before making any assembly, adjustments or changing accessories. Such preventive safety measures reduce the risk of starting the tool accidentally.

1. Lock the trigger switch on the hammer drill by placing the direction-of-rotation selector in the center position.
2. Rotate the chuck sleeve counterclockwise when viewed from chuck end, and open the chuck to the approximate drill-bit diameter.
3. Insert a bit up to the drill bit flutes for small bits, or as far as it will go for large bits.
4. Close the chuck by rotating the chuck sleeve clockwise when viewed from chuck end and securely tighten it by hand.

WARNING: Do not use the power of the hammer drill while grasping chuck to loosen or tighten the chuck on the bit. A friction burn or hand injury is possible if attempting to grasp the spinning chuck.

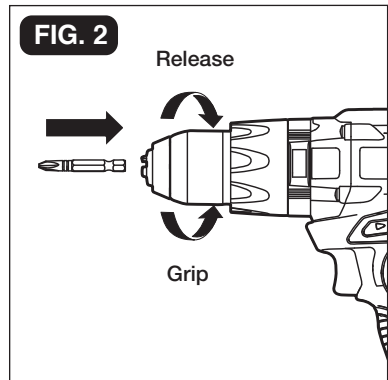

REMOVING BITS (FIG. 2)

1. Lock the trigger switch by placing the direction-of-rotation selector in the center position.
2. Rotate the chuck sleeve counterclockwise when viewed from the chuck end.
3. Remove the bit.

WARNING: Use protective gloves when removing the bit from the tool, or first allow the bit to cool down. The bit may be hot after prolonged use.

ASSEMBLY

INSTALLING AND REMOVING THE BELT CLIP (FIG. 3)

To install the belt clip:

1. Remove the battery from the tool.
2. Align the rib of the clip with the hole on the base of the hammer drill.
3. Insert the screw (included) and tighten the screw securely with a screwdriver (not included). The belt clip can be positioned on either side of the tool.

To remove the belt clip:

1. Remove the battery from the tool.
2. Use a screwdriver to loosen the screw that attaches the belt clip to the hammer drill.
3. Remove the screw and the belt clip.

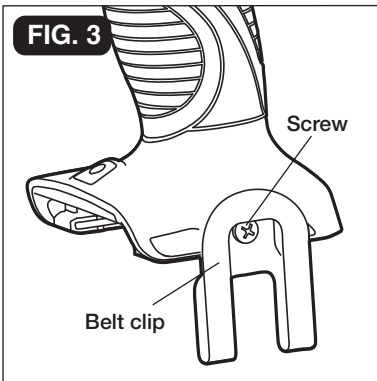

INSTALLING AND REMOVING THE BIT HOLDER (FIG. 4)

To install the bit holder:

1. Remove the battery from the tool.
2. Align the rib of the bit holder with the hole in the base of the hammer drill.
3. Insert the screw (included) and tighten the screw securely with a screwdriver (not included). The bit holder can be positioned on either side of the tool.

To remove the bit holder:

1. Remove the battery from the tool.
2. Use a screwdriver to loosen the screw that attaches the bit holder to the hammer drill.
3. Remove the screw and the bit holder.

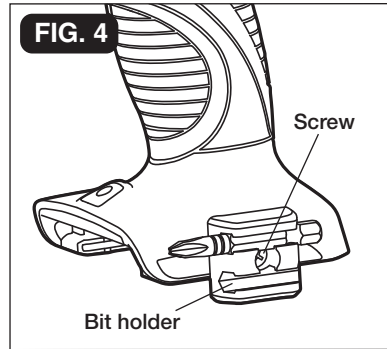

INSTALLING AND REMOVING THE SIDE HANDLE (FIG. 5)

WARNING: To reduce the risk of injury, always use a side handle when using this tool. Always hold it securely. Ensure that side handle is tightened securely before each use.

To install the side handle:

1. Remove the battery from the tool.
2. Loosen the side handle grip until the hooks are far enough apart to fit into the slots on the gear-case ring.
3. Position the side handle on the left or the right side of the tool.
4. Slide the hooks into the slots as far as the hooks will go.
5. Tighten the side handle grip until it is secure.

To remove the side handle:

1. Remove the battery from the tool.
2. Loosen the side handle grip until the side handle can be removed.

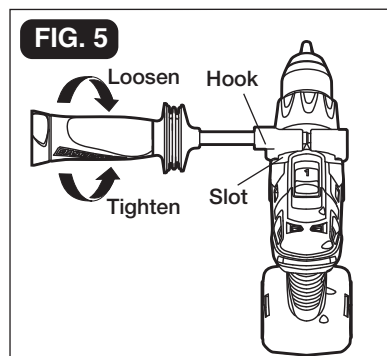

OPERATION

VARIABLE-SPEED TRIGGER SWITCH (FIG. 6)

1. To turn the hammer drill ON, press the trigger switch.
2. To turn the hammer drill OFF, release the trigger switch.
3. The variable-speed trigger switch delivers higher speed with increased trigger pressure and lower speed with decreased trigger pressure.

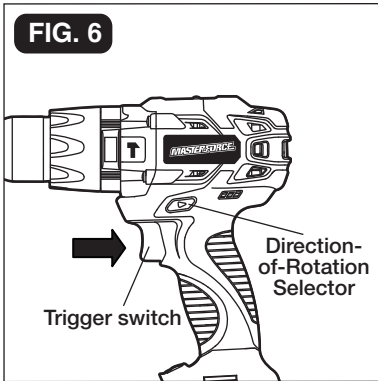

ELECTRIC BRAKE

When the trigger switch is released, it activates the brake to stop the chuck quickly. This is especially useful in the repetitive driving and removal of screws.

DIRECTION-OF-ROTATION SELECTOR (FIG. 7)

The direction of bit rotation is reversible and is controlled by a selector located above the trigger switch. With the hammer drill held in the normal operating position:

1. Position the direction-of-rotation selector to the left of the tool for forward rotation.
2. Position the direction-of-rotation selector to the right of the tool for reverse rotation.
3. Setting the direction-of-rotation selector in the OFF (center-lock) position helps reduce the possibility of accidental starting when not in use.

NOTICE: To prevent gear damage, always allow the hammer drill to come to a complete stop before changing the direction of rotation.

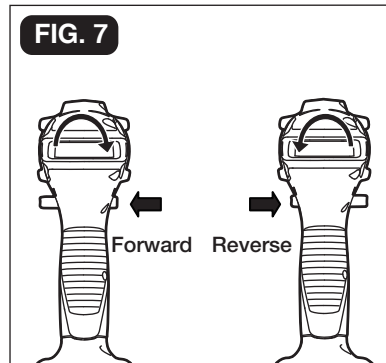

OPERATION

ADJUSTABLE CLUTCH (FIG. 10)

Your tool features 24 clutch settings. Output torque will increase as the torque-adjustment ring is rotated from 1 to 24. When using the hammer drill for different driving applications, it is necessary to increase or decrease the torque in order to help prevent the possibility of damaging screw heads, threads, workpiece, etc.

The proper setting depends on the job and the type of bit, fastener, and material you will be using. In general, use greater torque for larger screws, but if the torque is too high, the screws may be damaged or broken.

For delicate operations, such as removing a partially stripped screw, use a low torque setting. For operations such as drilling into hardwood, use a higher torque setting.

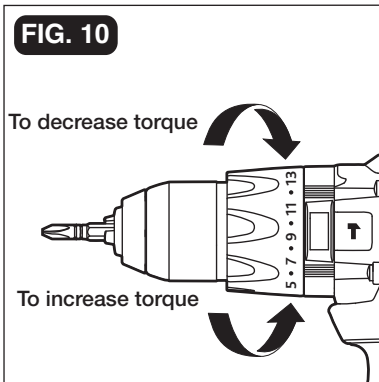

LED WORKLIGHT (FIG. 11)

Your tool is equipped with a light that turns on automatically when the switch is activated to provide better visibility when drilling/driving.

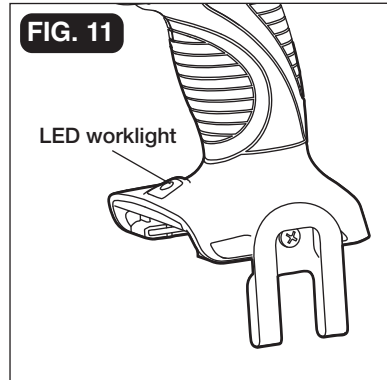

DRILLING (FIG. 12)

WARNING: To reduce the risk of injury, always use the side handle when using this tool. Always hold it securely. Ensure that the side handle is tightened securely before each use.

1. Check that the direction-of-rotation selector for the correct setting.
2. Secure the material to be drilled in a vise or with clamps to keep it from turning as the drill bit rotates.
3. Hold the drill firmly and place the bit at the point to be drilled.
4. Depress the trigger switch to start the drill.
5. Move the drill bit into the workpiece, applying only enough pressure to keep the bit cutting. Do not force the drill or apply side pressure to elongate a hole. Let the tool do the work.
6. When drilling hard, smooth surfaces, use a center punch to mark the desired location of the hole. This will prevent the drill bit from slipping off center as the hole is started.
7. When drilling metals, use light oil on the drill bit to keep it from overheating. The oil will prolong the life of the bit and increase the drilling action.

OPERATION

8. If the bit jams in the workpiece or if the drill stalls, stop the tool immediately. Remove the bit from the workpiece and determine the reason for jamming.

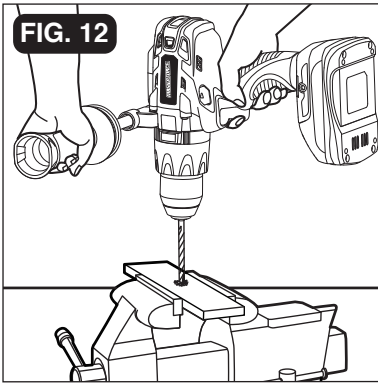

WOOD DRILLING

For maximum performance, use high-speed steel or brad point bits for wood drilling.

1. Begin drilling at a very low speed to prevent the bit from slipping off the starting point.
2. Increase speed as the drill bit bites into the material.
3. When drilling “through” holes, place a block of wood behind the workpiece to prevent ragged or splintered edges on the back side of the hole.

METAL DRILLING

For maximum performance, use high-speed steel bits for metal or steel drilling.

1. When drilling metals, use a light oil on the drill bit to keep it from overheating. The oil will prolong the life of the bit and increase the drilling action.
2. Begin drilling at a very low speed to prevent the bit from slipping off of the starting point.
3. Maintain a speed and pressure that allows cutting without overheating the bit. Applying too much pressure will:
 - Overheat the hammer drill.
 - Wear the bearings.
 - Bend or burn bits.
 - Produce off-center or irregular-shaped holes.

MASONRY DRILLING

For maximum performance, use high-speed steel bits for masonry drilling.

1. When drilling in masonry, select the hammer drill operating mode.
2. Drilling soft masonry materials such as cinder block requires little pressure. Hard materials like concrete require more pressure.
3. A smooth, even flow of dust indicates the proper drilling rate. Do not let the bit spin in the hole without cutting. Do not use water to settle dust or to cool bit.

WARNING: Always wear safety goggles or safety glasses with side shields during power tool operation or when blowing dust. If operation is dusty, also wear a dust mask.

MAINTENANCE

WARNING: To avoid serious personal injury, always remove the battery pack from the tool when cleaning or performing any maintenance.

WARNING: When servicing, use only identical replacement parts. Use of any other parts may create a hazard or cause product damage.

WARNING: It is not recommended to use compressed dry air as cleaning method of the hammer drill. If cleaning with compressed air is the only method to apply, always wear safety goggles or safety glasses with side shields when using compressed air to clean the tool. If the operation is dusty, also wear a dust mask.

GENERAL MAINTENANCE

Avoid using solvents when cleaning plastic parts. Most plastics are susceptible to damage from various types of commercial solvents. Use clean cloth to remove dirt, dust, oil, grease, etc.

WARNING: Do not at any time allow brake fluids, gasoline, petroleum-based products, penetrating oils, etc. to come in contact with plastic parts. Chemicals can damage, weaken or destroy plastic which may result in serious personal injury.

WARNING: When servicing, use only identical replacement parts. Use of any other parts may create a hazard or cause product damage. To ensure safety and reliability, all repairs should be performed by a qualified service technician.

CHUCK REMOVAL (FIG. 13)

The chuck can be removed and replaced with a new one.

1. Lock the trigger switch by placing the direction-of-rotation selector in the center position.
2. Open the chuck jaws. Using a screwdriver, remove the chuck screw by turning it clockwise,
3. Insert a 5/16-in. or larger hex key into the chuck of the hammer drill and tighten the chuck jaws securely.
4. Tap the hex key sharply with a mallet in a counterclockwise direction. This will loosen the chuck for easy removal.
5. Attach a new chuck to the spindle and tighten the chuck screw.

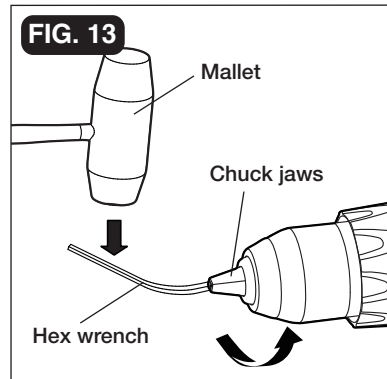

TROUBLESHOOTING

PROBLEM	CAUSE	SOLUTION
The hammer drill does not work.	The battery is depleted.	Charge the battery.
The bit cannot be installed.	The sleeve is not released.	Release the sleeve.
	The bit does not fit the sleeve.	Use a suitable bit.



Brushless 1/2" Hammer Drill WARRANTY

90-DAY MONEY BACK GUARANTEE:

This MASTERFORCE® brand power tool carries our 90-DAY Money Back Guarantee. If you are not completely satisfied with your MASTERFORCE® brand power tool for any reason within ninety (90) days from the date of purchase, return the tool with your original receipt to any MENARDS® retail store, and we will provide you a refund – no questions asked.

3-YEAR LIMITED WARRANTY:

This MASTERFORCE® brand power tool carries our famous No Hassle 3-Year Limited Warranty to the original purchaser. If, during normal use, this MASTERFORCE® power tool breaks or fails due to a defect in material or workmanship within three (3) years from the date of original purchase, simply bring this tool with the original sales receipt back to your nearest MENARDS® retail store. At its discretion, MASTERFORCE® agrees to have the tool or any defective part(s) repaired or replaced with the same or similar MASTERFORCE® product or part free of charge, within the stated warranty period, when returned by the original purchaser with original sales receipt. Notwithstanding the foregoing, this limited warranty does not cover any damage that has resulted from abuse or misuse of the Merchandise. This warranty: (1) excludes expendable parts including but not limited to blades, brushes, belts, bits, light bulbs, and/or batteries; (2) shall be void if this tool is used for commercial and/or rental purposes; and (3) does not cover any losses, injuries to persons/property or costs. This warranty does give you specific legal rights and you may have other rights, which vary from state to state. Be careful, tools are dangerous if improperly used or maintained. Seller's employees are not qualified to advise you on the use of this Merchandise. Any oral representation(s) made will not be binding on seller or its employees. The rights under this limited warranty are to the original purchaser of the Merchandise and may not be transferred to any subsequent owner. This limited warranty is in lieu of all warranties, expressed or implied including warranties or merchantability and fitness for a particular purpose. Seller shall not be liable for any special, incidental, or consequential damages. The sole exclusive remedy against the seller will be for the replacement of any defects as provided herein, as long as the seller is willing or able to replace this product or is willing to refund the purchase price as provided above. For insurance purposes, seller is not allowed to demonstrate any of these power tools for you.

For questions / comments, technical assistance or repair parts – Please Call Toll Free: 1-866-917-4374 (M-F 8:30am-5:00pm EST).

**SAVE YOUR RECEIPTS
THIS WARRANTY IS VOID WITHOUT THEM**

MASTER★FORCE®

MENARDS®

MASTERFORCE®

Brushless Circular Saw

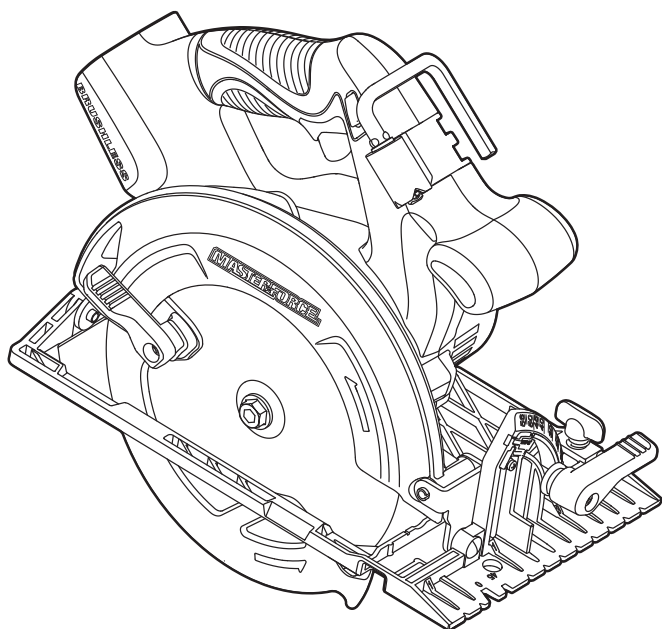

241-0490

OPERATOR'S MANUAL

⚠ CAUTION: To Reduce The Risk Of Injury, User Must Read And Understand Operator's Manual. Save These Instructions For Future Reference.



For questions / comments, technical assistance or repair parts –
Please Call Toll Free: 1-866-917-4374 (M-F 8:30am-5:00pm EST).

TABLE OF CONTENTS

Safety Symbols	Page 2
Safety Instructions	Page 3
Overview/Specifications	Page 8
Assembly	Page 9
Operation	Page 12
Maintenance	Page 17
Troubleshooting	Page 18
Warranty	Page 22

SAFETY SYMBOLS

Some of these following symbols may be used on this tool. Please study them and learn their meaning. Proper interpretation of these symbols will allow you to operate the tool better and more safely.

Symbol	Name	Designation / Explanation
V	Volts	Voltage
A	Amperes	Current
Hz	Hertz	Frequency (cycles per second)
W	Watts	Power
~	Alternating current	Type of current
—	Direct current	Type or characteristic of current
n ₀	No-load speed	Rotational speed at no load
	Class II construction	Double insulated construction
.../min	Per minute	Revolutions, strokes, surface speed orbits, etc., per minute
	Wear safety goggles	⚠ WARNING: The operation of any power tool can result in foreign objects being thrown into your eyes, which can result in severe eye damage. Before beginning power tool operation, always wear safety goggles or safety glasses with side shields and a full-face shield when needed. We recommend a Wide Vision Safety Mask for use over eye-glasses or standard safety glasses with side shields. Always use eye protection which is marked to comply with ANSI Z87.1.

⚠ WARNING: To ensure safety and reliability, all repairs should be performed by a qualified service technician.

SAFETY INSTRUCTIONS

The purpose of safety symbols is to attract your attention to possible dangers. The safety symbols, and the explanations with them, deserve your careful attention and understanding. The symbol warnings do not, by themselves, eliminate any danger. The instructions and warnings they give are no substitutes for proper accident prevention measures.

 **WARNING:** Be sure to read and understand all safety instructions in this manual, including all safety alert symbols such as “DANGER”, “WARNING” and “CAUTION” before using this tool. Failure to following all instructions listed below may result in electric shock, fire, and/or serious personal injury.

SYMBOL MEANING



SAFETY ALERT SYMBOL: Indicates DANGER, WARNING, OR CAUTION.

May be used in conjunction with other symbols or pictographs.



DANGER: Indicates an imminently hazardous situation, which, if not avoided, will result in death or serious injury.



WARNING: Indicates a potentially hazardous situation, which, if not avoided, could result in death or serious injury.



CAUTION: Indicates a potentially hazardous situation, which, if not avoided, could result in minor or moderate injury.

NOTICE: (Without Safety Alert Symbol) Indicates a situation that may result in property damage.

SAVE THESE INSTRUCTIONS!

SAFETY INSTRUCTIONS

GERNERAL POWER TOOL SAFETY WARNINGS

 **WARNING:** Read all safety warnings and all instructions. Failure to follow the warnings and instructions may result in electric shock, fire and/or serious injury.

Save all warnings and instructions for future reference.

The term “power tool” in the warnings refers to your mains-operated (corded) power tool or battery-operated (cordless) power tool.

WORK AREA SAFETY

1. Keep work area clean and well lit. Cluttered and dark areas invite accidents.
2. Do not operate power tools in explosive atmospheres, such as in the presence of flammable liquids, gases or dust. Power tools create sparks which may ignite the dust or fumes.
3. Keep children and bystanders away while operating a power tool. Distractions can cause you to lose control

ELECTRICAL SAFETY

1. Power tool plugs must match the outlet. Never modify the plug in any way. Do not use any adapter plugs with earthed (grounded) power tools. Unmodified plugs and matching outlets will reduce risk of electric shock.
2. Avoid body contact with earthed or grounded surfaces, such as pipes, radiators, ranges and refrigerators. There is an increased risk of electric shock if your body is earthed or grounded.
3. Do not expose power tools to rain or wet conditions. Water entering a power tool will increase the risk of electric shock.
4. Do not abuse the cord. Never use the cord for carrying, pulling or unplugging the power tool. Keep cord away from heat, oil, sharp edges or moving parts. Damaged or entangled cords increase the risk of electric shock.

5. When operating a power tool outdoors, use an extension cord suitable for outdoor use. Use of a cord suitable for outdoor use reduces the risk of electric shock.
6. If operating a power tool in a damp location is unavoidable, use a ground-fault circuit interrupter (GFCI) protected supply. Use of a GFCI reduces the risk of electric shock.

PERSONAL SAFETY

1. Stay alert, watch what you are doing and use common sense when operating a power tool. Do not use a power tool while you are tired or under the influence of drugs, alcohol or medication. A moment of inattention while operating power tools may result in serious personal injury.
2. Use personal protective equipment. Always wear eye protection. Protective equipment such as dust mask, non-skid safety shoes, hard hat, or hearing protection used for appropriate conditions will reduce personal injuries.
3. Prevent unintentional starting. Ensure the switch is in the off-position before connecting to power source and/or battery pack, picking up or carrying the tool. Carrying power tools with your finger on the switch or energising power tools that have the switch on invites accidents.
4. Remove any adjusting key or wrench before turning the power tool on. A wrench or a key left attached to a rotating part of the power tool may result in personal injury.
5. Do not overreach. Keep proper footing and balance at all times. This enables better control of the power tool in unexpected situations.
6. Dress properly. Do not wear loose clothing or jewellery. Keep your hair, clothing and gloves away from moving parts. Loose clothes, jewellery or long hair can be caught in moving parts.
7. If devices are provided for the connection of dust extraction and collection facilities, ensure that these are connected and properly used. Use of these devices can reduce dust-related hazards.

SAFETY INSTRUCTIONS

POWER TOOL USE AND CARE

1. Do not force the power tool. Use the correct power tool for your application. The correct power tool will do the job better and more safely at the rate for which it was designed.
2. Do not use the power tool if the switch does not turn it on and off. Any power tool that cannot be controlled with the switch is dangerous and must be repaired.
3. Disconnect the plug from the power source and/or the battery pack from the power tool before making any adjustments, changing accessories, or storing power tools. Such preventive safety measures reduce the risk of starting the power tool accidentally.
4. Store idle power tools out of the reach of children and do not allow persons unfamiliar with the power tool or these instructions to operate the power tool. Power tools are dangerous in the hands of untrained users.
5. Maintain power tools. Check for misalignment or binding of moving parts, breakage of parts and any other condition that may affect the power tool's operation. If damaged, have the power tool repaired before use. Many accidents are caused by poorly maintained power tools.
6. Keep cutting tools sharp and clean. Properly maintained cutting tools with sharp cutting edges are less likely to bind and are easier to control.
7. Use the power tool, accessories, tool bits, etc. in accordance with these instructions, taking into account the working conditions and the work to be performed. Use of the power tool for operations different from those intended could result in a hazardous situation.

BATTERY TOOL USE AND CARE

1. Recharge only with the charger specified by the manufacturer. A charger that is suitable for one type of battery pack may create a risk of fire when used with another battery pack.
2. Use power tools only with specifically designated battery packs. Use of any other battery packs may create a risk of injury and fire.

3. When battery pack is not in use, keep it away from other metal objects, like paper clips, coins, keys, nails, screws or other small metal objects, that can make a connection from one terminal to another. Shorting the battery terminals together may cause burns or a fire.
4. Under abusive conditions, liquid may be ejected from the battery; avoid contact. If contact accidentally occurs, flush with water. If liquid contact eyes, additionally seek medical help. Liquid ejected from the battery may cause irritation or burns.

SERVICE

1. Have your power tool serviced by a qualified repair person using only identical replacement parts. This will ensure that the safety of the power tool is maintained.

SPECIFIC SAFETY RULES FOR CIRCULAR SAWS

CUTTING PROCEDURES

 **DANGER:** Keep hands away from cutting area and the blade. Keep your second hand on auxiliary handle, or motor housing. If both hands are holding the saw, they cannot be cut by the blade.

1. Do not reach underneath the workpiece. The guard cannot protect you from the blade below the workpiece.
2. Adjust the cutting depth to the thickness of the workpiece. Less than a full tooth of the blade teeth should be visible below the workpiece.
3. Never hold piece being cut in your hands or across your leg. Secure the workpiece to a stable platform. It is important to support the work properly to minimize body exposure, blade binding, or loss of control.
4. Hold the power tool by insulated gripping surfaces only, when performing an operation where the cutting tool may contact hidden wiring. Contact with a "live" wire will also make exposed metal parts of the power tool "live" and could give the operator an electric shock.

SAFETY INSTRUCTIONS

5. When ripping, always use a rip fence or straight edge guide. This improves the accuracy of cut and reduces the chance of blade binding.
6. Always use blades with correct size and shape (diamond versus round) of arbor holes. Blades that do not match the mounting hardware of the saw will run eccentrically, causing loss of control.
7. Never use damaged or incorrect blade washers or bolt. The blade washers and bolt were specially designed for your saw, for optimum performance and safety of operation.

KICKBACK AND RELATED WARNINGS

Causes and operator prevention of kickback:

Kickback is a sudden reaction to a pinched, bound or misaligned saw blade, causing an uncontrolled saw to lift up and out of the workpiece toward the operator.

When the blade is pinched or bound tightly by the kerf closing down, the blade stalls and the motor reaction drives the unit rapidly back toward the operator.

If the blade becomes twisted or misaligned in the cut, the teeth at the back edge of the blade can dig into the top surface of the wood causing the blade to climb out of the kerf and jump back toward the operator.

Kickback is the result of saw misuse and/or incorrect operating procedures or conditions and can be avoided by taking proper precautions as given below:

1. Maintain a firm grip with both hands on the saw and position your arms to resist kickback forces. Position your body to either side of the blade, but not in line with the blade. Kickback could cause the saw to jump backwards, but kickback forces can be controlled by the operator, if proper precautions are taken.
2. When blade is binding, or when interrupting a cut for any reason, release the trigger and hold the saw motionless in the material until the blade comes to a complete stop. Never attempt to remove the saw from the work or pull the saw backward while the blade is in motion or kickback may occur.

Investigate and take corrective actions to eliminate the cause of blade binding.

3. When restarting a saw in the workpiece, centre the saw blade in the kerf and check that saw teeth are not engaged into the material. If saw blade is binding, it may walk up or kickback from the workpiece as the saw is restarted.
4. Support large panels to minimise the risk of blade pinching and kickback. Large panels tend to sag under their own weight. Supports must be placed under the panel on both sides, near the line of cut and near the edge of the panel.
5. Do not use dull or damaged blades. Unsharpened or improperly set blades produce narrow kerf causing excessive friction, blade binding and kickback.
6. Blade depth and bevel adjusting locking levers must be tight and secure before making cut. If blade adjustment shifts while cutting, it may cause binding and kickback.
7. Use extra caution when sawing into existing walls or other blind areas. The protruding blade may cut objects that can cause kickback.

LOWER GUARD FUNCTION

1. Check lower guard for proper closing before each use. Do not operate the saw if lower guard does not move freely and close instantly. Never clamp or tie the lower guard into the open position. If saw is accidentally dropped, lower guard may be bent. Raise the lower guard with the retracting handle and make sure it moves freely and does not touch the blade or any other part, in all angles and depths of cut.
2. Check the operation of the lower guard spring. If the guard and the spring are not operating properly, they must be serviced before use. Lower guard may operate sluggishly due to damaged parts, gummy deposits, or a build-up of debris.
3. Lower guard may be retracted manually only for special cuts such as "plunge cuts" and "compound cuts". Raise lower guard by retracting handle and as soon as blade enters the material, the lower guard must be released. For all other sawing, the lower guard should operate automatically.

SAFETY INSTRUCTIONS

4. Always observe that the lower guard is covering the blade before placing saw down on bench or floor. An unprotected, coasting blade will cause the saw to walk backwards, cutting whatever is in its path. Be aware of the time it takes for the blade to stop after switch is released.

ADDITIONAL SAFETY RULES FOR CIRCULAR SAWS

1. Use battery only with charger listed below.

Battery pack	Charger
252-8024	252-8025
252-8029	252-8036
252-8030	252-8037
252-8031	252-8044
252-8032	
252-8033	
252-8034	
252-8035	

2. Wear personal protective equipments. Depending on application, use dust mask, safety goggles or safety glasses for eye protection. Wear hearing protectors, gloves and workshop apron capable of stopping small metal chips or workpiece fragments. The eye protection must be capable of stopping flying debris generated by various operations. The gloves, workshop apron and clothing must be fire resistant. Prolonged exposure to high intensity noise may cause hearing loss. Using protective equipments will reduce the risk of personal injuries.

3. Do not handle workpiece without wearing gloves. The sharp edge of workpiece may cause a laceration hazard.

4. Ensure the switch is in the off position before inserting battery pack. Inserting the battery pack into power tools that have the switch on invites accidents.

5. Do not use dull blade. Additional sparks generated by using dull blade increase the risk of a fire hazard.

6. Do not use with any abrasive wheels, just only use with 7-1/4" wood blade.

7. Do not use cutting oil. The use of cutting oil may cause a fire.

8. Do not use tool near flammable material.

9. This circular saw should not be mounted to a table and converted to a table saw. Circular saws are not designed or intended to be used as table saws.

10. The blade washers and the bolt on your saw have been designed to work as a clutch to reduce the intensity of a kickback. Understand the operation and settings of the VARI-TORQUE CLUTCH. The proper setting of the clutch, combined with firm handling of the saw will allow you to control kickback.

11. Do not run the tool while carrying it at your side. Lower guard may be opened by a contact with your clothing. Accidental contact with the spinning saw blade could result in serious personal injury.

12. Periodically remove the blade, clean the upper, lower guards and the hub area. Wipe it dry, or blow it clean with compressed air. Preventive maintenance and properly operating guard will reduce the probability of an accident.

13. Do not use the saw with an excessive depth of cut setting. Too much blade exposure increases the likelihood of the blade twisting in the kerf and increases the surface area of the blade available for pinching that leads to kickback.

 **WARNING:** Some dust created by power sanding, sawing, grinding, drilling and other construction activities contains chemicals known to the state of California to cause cancer, birth defects or other reproductive harm. Some examples of these chemicals are:

- Lead from lead-based paints
- Crystalline silica from bricks and cement and other masonry products, and
- Arsenic and chromium from chemically-treated lumber.

Your risk from these exposures varies, depending on how often you do this type of work. To reduce your exposure to these chemicals: work in a well ventilated area, and work with approved safety equipment, such as those dust masks that are specially designed to filter out microscopic particles.

OVERVIEW

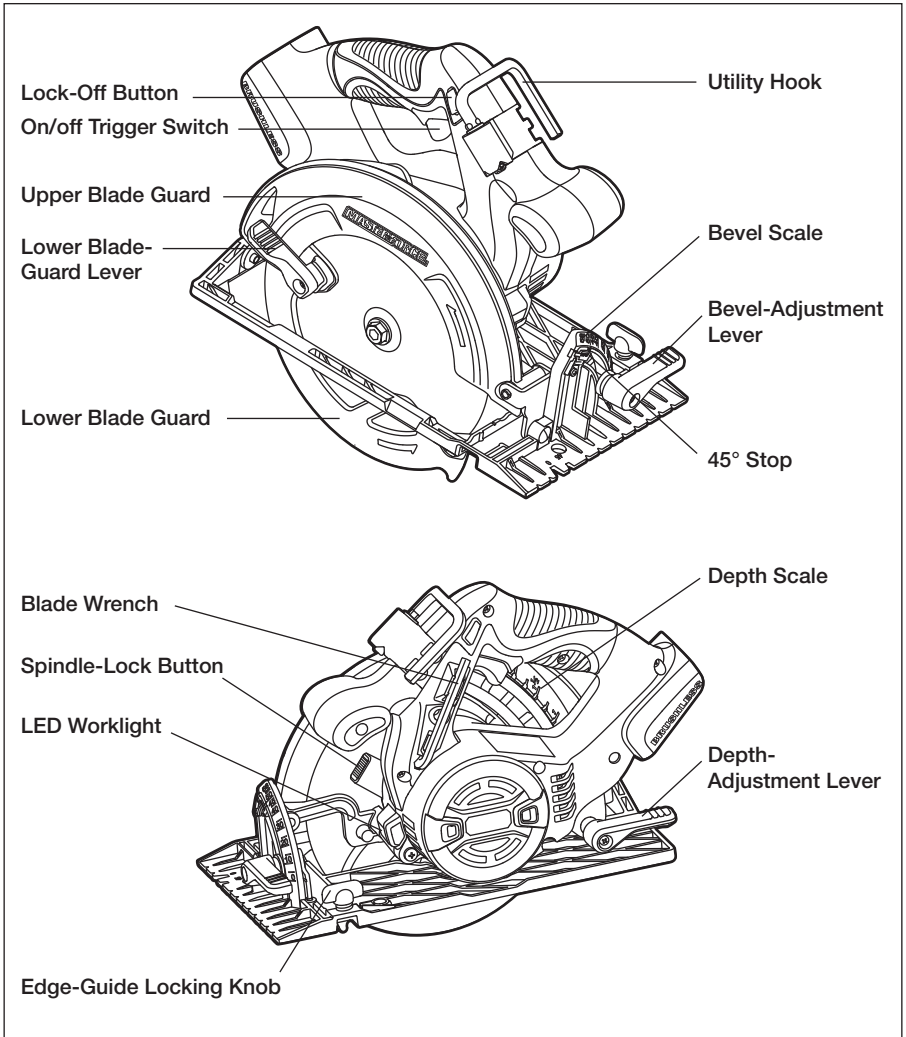

SPECIFICATIONS

No-load speed	4,500 RPM
Blade Diameter	7-1/4" (18.5 cm)
Blade Arbor	5/8" (16 mm)
Cutting Depth at 90°	2-7/16"
Cutting Depth at 45°	1-13/16"
Bevel range	0-56°
Tool weight (without battery)	7 lb. 11 oz. (3.5 kg)

ASSEMBLY

WARNING: If any part is broken or missing, **DO NOT** attempt to install the battery or operate the tool until the broken or missing part is replaced. Failure to do so could result in possible serious injury.

WARNING: Do not attempt to modify this tool or create accessories not recommended for use with this tool. Any such alteration or modification is misuse and could result in a hazardous condition leading to possible serious injury.

WARNING: Your tool should never be connected to the power source (battery) when you are assembling parts, making adjustments, installing or removing blades, cleaning, or when it is not in use. Disconnecting the tool will prevent accidental starting, which could cause serious personal injury.

CONTENTS

Cordless circular saw, blade (attached on the tool), blade wrench (attached on the tool), instruction manual.

UNPACKING

1. Carefully remove the tool and any accessories from the carton. Make sure that all items listed in the packing list are included.
2. Inspect the tool carefully to make sure that no breakage or damage occurred during shipping.
3. Do not discard the packing material until you have carefully inspected and satisfactorily operated the tool.

TO ATTACH BATTERY PACK (FIG. 1)

1. Make sure that the tool is turned off.
2. Align the raised rib on the battery pack with the grooves on the bottom of the saw, and then slide the battery pack onto the tool.

NOTICE: Make sure that the latch on the battery pack snaps into place and the battery pack is secured to the tool before operation.

TO DETACH BATTERY PACK (FIG. 1)

1. Make sure that the tool is turned off.
2. Depress the battery-release buttons located on the front of the battery pack to release the battery pack.
3. Pull the battery pack out and remove it from the tool.

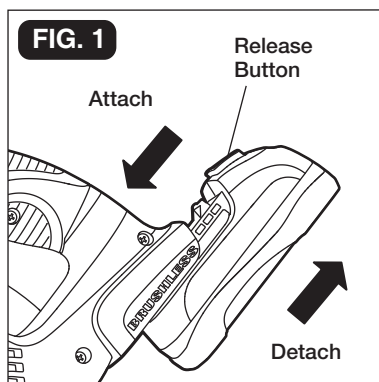

ASSEMBLY

INSTALLING THE SAW BLADE (FIG. 2)

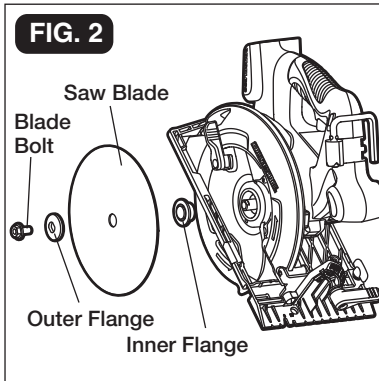

1. Remove the battery pack from the tool.
2. Depress and hold the spindle-lock button.
3. Loosen the blade bolt by turning it counterclockwise with the blade wrench (included).
4. Remove the blade bolt and outer flange.
5. Use the lower blade-guard lever to retract the lower blade guard into the upper blade guard.
6. Fit the saw blade inside the lower blade guard and onto the spindle. Verify that the saw teeth, the arrow on the saw blade and the blade-rotation indicator arrow on the blade guard are all pointing in the same direction.
7. Replace the outer blade flange with the protuberance facing outward.
8. Depress and hold the spindle-lock button, and replace the blade bolt.
9. Tighten the blade bolt securely by turning it clockwise with the blade wrench.

NOTICE: Never use a blade that is too thick to allow the outer blade flange to engage with the flat section of the spindle.

WARNING: Remove the battery pack from tool before making any assembly, adjustments or changing accessories. Such preventive safety measures reduce the risk of starting the tool accidentally.

WARNING: For all work and when changing the blade, always wear protective gloves. The sharp edges of the blade will cause personal injury. The blade can become very hot while working.

REMOVING THE SAW BLADE (FIG. 2)

1. Remove the battery pack from the tool.
2. Depress and hold the spindle-lock button.
3. Loosen the blade bolt by turning it counterclockwise with the blade wrench.
4. Remove the blade bolt and outer blade flange.
5. Lift the lower blade guard and then remove the blade.

ADJUSTING THE CUTTING DEPTH (FIG. 3)

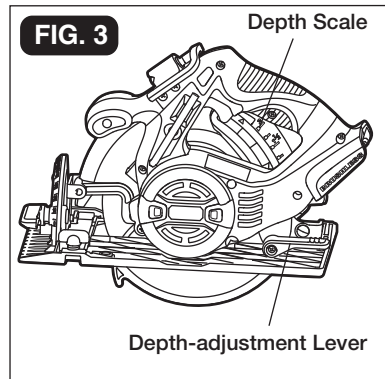

1. Remove the battery pack from the tool.
2. Raise the depth-adjustment lever to release it.
3. Hold the base shoe against the workpiece and raise or lower the saw until the indicator mark on the saw aligns with the desired depth on the depth scale.
4. Lower the depth-adjustment lever to lock it into position.

ASSEMBLY

ADJUSTING THE CUTTING ANGLE (FIG. 4)

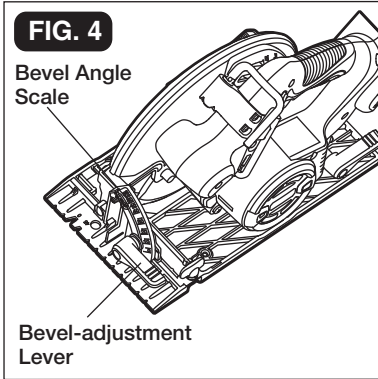

The saw is equipped with a 45° stop to quickly set up for 45° bevels. To set a 45-56° bevel, raise the stop.

1. Remove the battery pack from the tool.
2. Loosen the bevel-adjustment lever, located on the 0°-56° bevel scale.
3. Tilt the body of the saw until the indicator mark on the saw aligns with the required angle on the bevel angle scale.
4. Tighten the bevel-adjustment lever to secure the saw.

0° BEVEL STOP

The saw has a 0° bevel stop that has been adjusted before shipment to assure that the blade is vertical to the base at the 0° bevel setting.

TO CHECK 0° BEVEL STOP (FIG. 5)

1. Remove the battery pack from the tool.
2. Using a square ruler (available separately), check the squareness of the saw blade to the base of the saw.

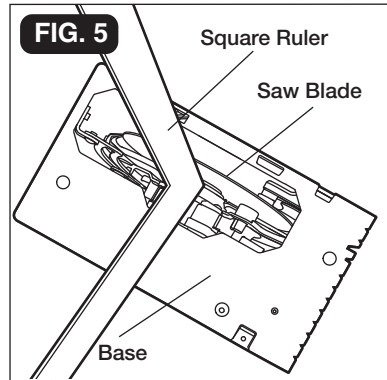

TO ADJUST 0° BEVEL STOP (FIG. 6)

1. Remove the battery pack from the tool.
2. Loosen the bevel-adjustment knob.
3. Use a hex wrench (available separately) to turn the adjusting screw until the base is square with the saw blade.

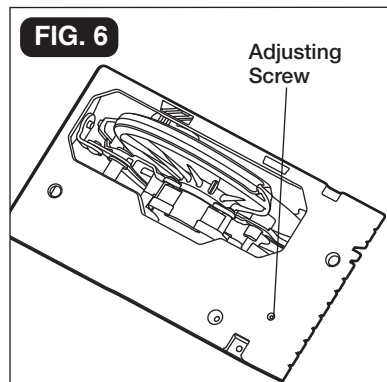

ASSEMBLY

LED WORKLIGHT (FIG. 7)

The circular saw is equipped with a LED worklight, which will illuminate when the trigger switch is depressed. This provides additional light on the surface of the workpiece for operation in lower-light areas. The light will stay on for 10 seconds after the trigger has been released.

NOTICE: In the event that the saw becomes overloaded or overheated, the saw will stop and the LED will blink. Remove the saw from the workpiece, allow it cool, and then resume work.

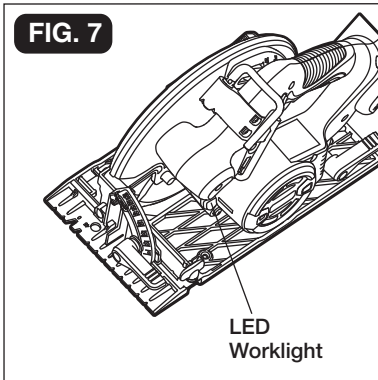

HOOK (FIG. 8)

Your tool is equipped with a convenient hook for hanging your tool. To use, simply lift up hook until it snaps into the open position.

When not in use for hanging, always lower hook until it snaps into the closed position.

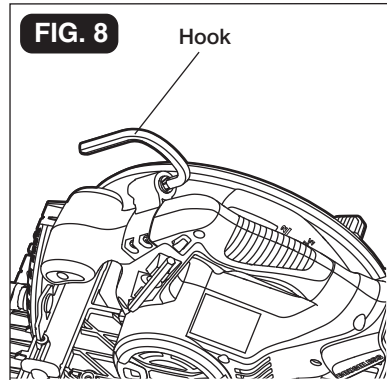

OPERATION

TURNING THE SAW ON AND OFF (FIG. 9)

1. To turn the saw ON, press the lock-off button, and then squeeze the trigger switch.
2. To turn the saw OFF, release the trigger switch and allow the blade to come to a complete stop.

WARNING: The blade should reach full speed before it comes into contact with the workpiece.

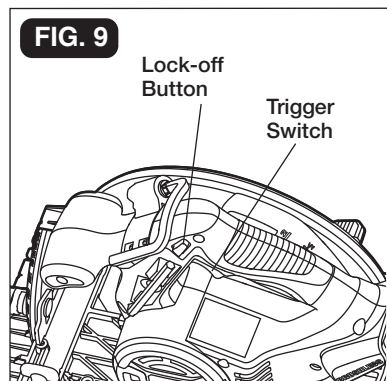

OPERATION

ELECTRIC BRAKE

The circular saw is equipped with an electric brake. When the trigger switch is released, the electric brake engages automatically to quickly stop the blade rotation.

CUTTING WITH THE CIRCULAR SAW (FIG. 10A, 10B & 10C)

To make the safest and best possible cut, follow these helpful hints:

- Hold the saw firmly with both hands.
- Avoid placing your hand on the workpiece while making a cut (FIG. 10A).
- Support the workpiece so that the cut is always to the operator's side and not directly in line with the operator's body.
- Support the workpiece near the cut.
- Clamp the workpiece securely so that the workpiece will not move during the cut (FIG. 10B).
- Always place the saw on the portion of the workpiece that is supported, and not on the "cut off" piece (FIG. 10C).
- Place the workpiece with the "good" side down.
- Draw a guideline along the desired cutting line before beginning the cut.

NOTICE: The "good" side of the workpiece is the side where appearance is important.

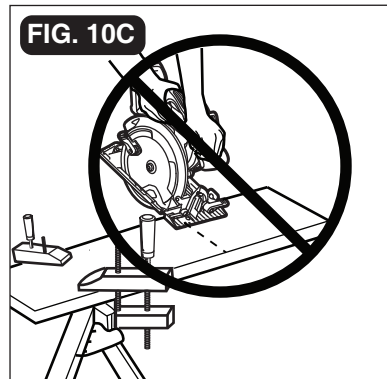
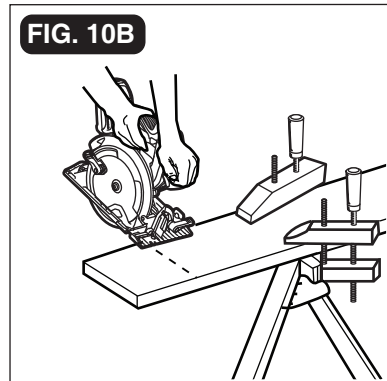
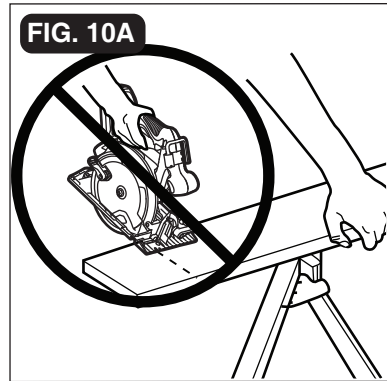

OPERATION

CROSS-CUTTING/RIP CUTTING (FIG. 11)

When making a cross-cut or a rip cut, align the guideline with the 0° indicator on the base shoe. Blade thicknesses vary, so you should always make a trial cut in scrap material along a guideline to determine how much the guideline must be offset from the indicator to produce an accurate cut.

NOTICE: Use a guide when making long or wide rip cuts.

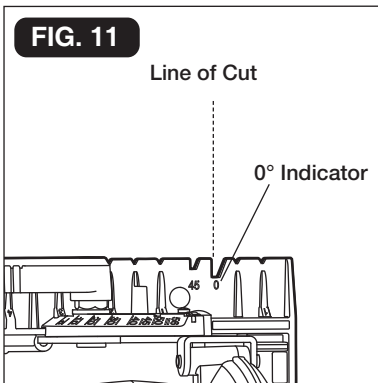

RIP CUTTING USING A STRAIGHT EDGE (FIG. 12)

1. Secure the workpiece.
2. Clamp a straight edge to the workpiece using C-clamps (available separately).
3. Press the lock-off button and depress the trigger switch to start the saw.
4. Allow the blade to reach full speed, then guide the saw into the workpiece and make the cut.
5. Saw along the straight edge to achieve a straight rip cut.
6. Release the trigger switch and allow the blade to come to a complete stop.
7. Lift the saw from the workpiece.

WARNING: Position the C-clamps so that they will not interfere with the saw housing during the cut.

WARNING: Do not bind the blade in the cut.

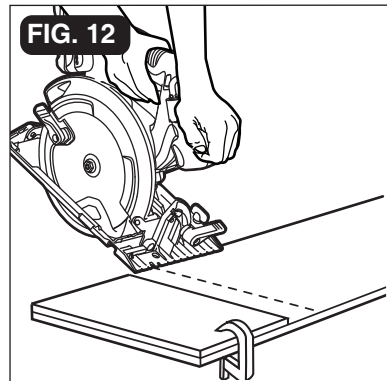

OPERATION

BEVEL CUTTING (FIG. 13)

1. Remove the battery pack from the tool.
2. Adjust the angle of cut to any desired setting, between 0° and 56° , according to the section "ADJUSTING THE CUTTING ANGLE".
3. Replace the battery pack.
4. Align the cutting line with the 45° blade-guide notch on the base shoe when making 45° bevel cuts.
5. Make a trial cut in scrap material along a guideline to determine the amount to offset the notch on the cutting material.
6. Hold the saw firmly with both hands.
7. Rest the front edge of the base shoe on the workpiece without touching the blade to the workpiece.
8. Start the saw and allow the blade to reach full speed.
9. Guide the saw into the workpiece, and make the cut.
10. Release the trigger switch and allow the blade to come to a complete stop.
11. Lift the saw from the workpiece.

WARNING: Attempting a bevel cut without having the bevel-locking knob securely locked in place can result in serious injury.

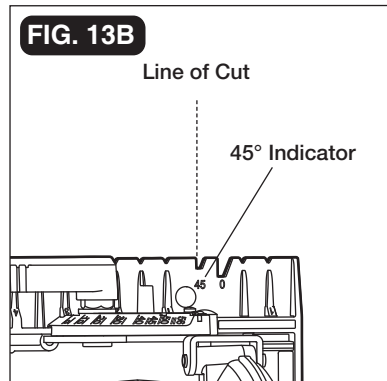
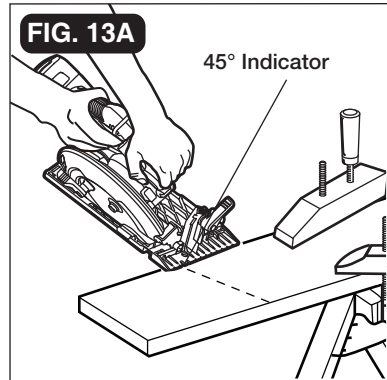

OPERATION

POCKET CUTTING (FIG. 14)

1. Remove the battery pack from the tool.
2. Adjust the bevel setting to 0° and tighten the bevel locking knob.
3. Set the blade to the correct blade cutting depth.
4. Replace the battery pack.
5. Use the blade-guard lever to swing the lower blade guard up.
6. Hold the lower blade guard in place with the blade-guard lever.
7. Rest the front of the base shoe against the workpiece, with the rear of the base shoe raised, making sure that the blade does not touch the workpiece.
8. Press the lock-off button and depress the trigger switch to start the saw.
9. Allow the blade to reach full speed, then lower the saw into the material and guide the saw into the workpiece and make the cut.
10. Release the trigger switch and allow the blade to come to a complete stop.
11. Lift the saw from the workpiece.

WARNING: Always adjust the bevel setting to 0° before making a pocket cut. Attempting a pocket cut at any other setting can result in loss of control of the saw and possible serious injury.

WARNING: Always cut in a forward direction when pocket cutting. Cutting in the reverse direction could cause the saw to climb up on the workpiece and kick back toward the operator.

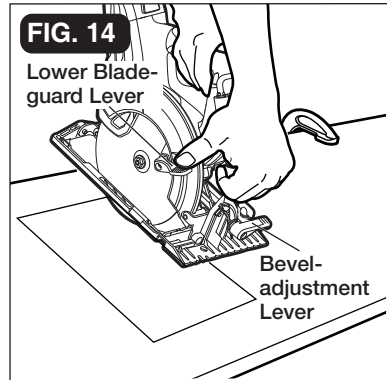

MAINTENANCE

 **WARNING:** Always wear safety goggles or safety glasses with side shields during power tool operations, or when blowing dust. If operation is dusty, also wear a dust mask.

 **WARNING:** Do not at any time let brake fluids, gasoline, petroleum-based products, penetrating oils, etc. come in contact with plastic parts. Chemicals can damage, weaken or destroy plastic, which may result in serious personal injury.

MAINTENANCE

The tool may be cleaned most effectively with compressed dry air. Always wear safety goggles when cleaning tools with compressed air.

Avoid using solvents when cleaning plastic parts. Most plastics are susceptible to damage from various types of commercial solvents and may be damaged by their use. Use a clean cloth to remove dirt, dust, oil, grease, etc.

BEFORE EACH USE

1. Inspect the circular saw, the on/off switch and the accessories for damage.
2. Check for damaged, missing, or worn parts.
3. Check for loose screws, misalignment or binding of moving parts, or any other condition that may affect the operation.
4. If abnormal vibration or noise occurs, turn the tool off immediately and have the problem corrected before further use.
5. Detach the battery from the saw before cleaning or performing any maintenance. Using compressed air may be the most effective cleaning method. Always wear safety goggles when cleaning tools using compressed air.

LUBRICATION

All of the bearings in this tool are lubricated with a sufficient amount of high grade lubricant for the life of the unit under normal conditions. Therefore, no further lubrication is required.

TROUBLESHOOTING

PROBLEM	CAUSE	SOLUTION
The saw does not work.	The battery is depleted.	Charge the battery.
The saw does not work and the tool LED worklight flashes.	The tool is overheated.	Allow the tool to cool down.
The saw does not work and two battery pack LED lights alternately flash.	The battery is overheated.	Allow the battery to cool down.
The saw does not work and the battery pack LED lights flash.	The battery is in overloaded protection.	Do not force the cut.
Cutting is difficult.	Saw blade is worn out.	Replace the saw blade.



Brushless Circular Saw **WARRANTY**

90-DAY MONEY BACK GUARANTEE:

This MASTERFORCE® brand power tool carries our 90-DAY Money Back Guarantee. If you are not completely satisfied with your MASTERFORCE® brand power tool for any reason within ninety (90) days from the date of purchase, return the tool with your original receipt to any MENARDS® retail store, and we will provide you a refund – no questions asked.

3-YEAR LIMITED WARRANTY:

This MASTERFORCE® brand power tool carries our famous No Hassle 3-Year Limited Warranty to the original purchaser. If, during normal use, this MASTERFORCE® power tool breaks or fails due to a defect in material or workmanship within three (3) years from the date of original purchase, simply bring this tool with the original sales receipt back to your nearest MENARDS® retail store. At its discretion, MASTERFORCE® agrees to have the tool or any defective part(s) repaired or replaced with the same or similar MASTERFORCE® product or part free of charge, within the stated warranty period, when returned by the original purchaser with original sales receipt. Notwithstanding the foregoing, this limited warranty does not cover any damage that has resulted from abuse or misuse of the Merchandise. This warranty: (1) excludes expendable parts including but not limited to blades, brushes, belts, bits, light bulbs, and/or batteries; (2) shall be void if this tool is used for commercial and/or rental purposes; and (3) does not cover any losses, injuries to persons/property or costs. This warranty does give you specific legal rights and you may have other rights, which vary from state to state. Be careful, tools are dangerous if improperly used or maintained. Seller's employees are not qualified to advise you on the use of this Merchandise. Any oral representation(s) made will not be binding on seller or its employees. The rights under this limited warranty are to the original purchaser of the Merchandise and may not be transferred to any subsequent owner. This limited warranty is in lieu of all warranties, expressed or implied including warranties of merchantability and fitness for a particular purpose. Seller shall not be liable for any special, incidental, or consequential damages. The sole exclusive remedy against the seller will be for the replacement of any defects as provided herein, as long as the seller is willing or able to replace this product or is willing to refund the purchase price as provided above. For insurance purposes, seller is not allowed to demonstrate any of these power tools for you.

For questions / comments, technical assistance or repair parts –
Please Call Toll Free: 1-866-917-4374 (M-F 8:30am-5:00pm EST).

**SAVE YOUR RECEIPTS
THIS WARRANTY IS VOID WITHOUT THEM**

MASTER★FORCE®

MENARDS®

MASTERFORCE®

BRUSHLESS RECIPROCATING SAW

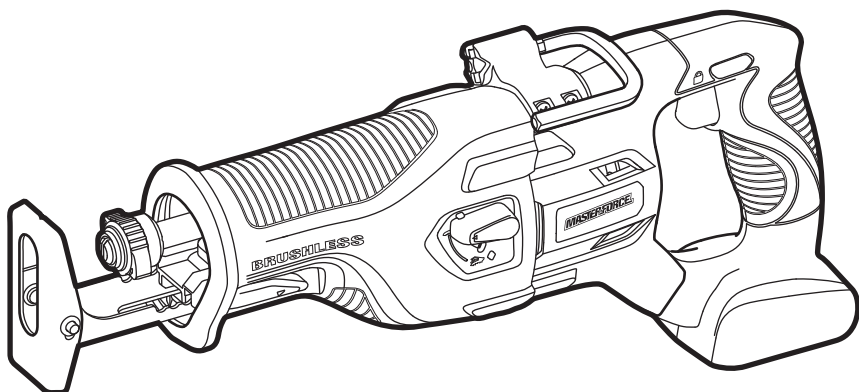

241-0492

OPERATOR'S MANUAL

⚠ CAUTION: To Reduce The Risk Of Injury, User Must Read And Understand Operator's Manual. Save These Instructions For Future Reference.



For questions / comments, technical assistance or repair parts –
Please Call Toll Free: 1-866-917-4374 (M-F 8:30am-5:00pm EST).

TABLE OF CONTENTS

Safety Symbols	Page 2
Safety Instructions	Page 3
Overview/Specifications	Page 7
Assembly	Page 8
Operation	Page 12
Maintenance	Page 15
Troubleshooting	Page 16
Warranty	Page 18

SAFETY SYMBOLS

Some of these following symbols may be used on this tool. Please study them and learn their meaning. Proper interpretation of these symbols will allow you to operate the tool better and more safely.

Symbol	Name	Designation / Explanation
V	Volts	Voltage
A	Amperes	Current
Hz	Hertz	Frequency (cycles per second)
W	Watts	Power
~	Alternating current	Type of current
≡	Direct current	Type or characteristic of current
n ₀	No-load speed	Rotational speed at no load
	Class II construction	Double insulated construction
.../min	Per minute	Revolutions, strokes, surface speed orbits, etc., per minute
	Wear safety goggles	⚠ WARNING: The operation of any power tool can result in foreign objects being thrown into your eyes, which can result in severe eye damage. Before beginning power tool operation, always wear safety goggles or safety glasses with side shields and a full-face shield when needed. We recommend a Wide Vision Safety Mask for use over eye-glasses or standard safety glasses with side shields. Always use eye protection which is marked to comply with ANSI Z87.1.

⚠ WARNING: To ensure safety and reliability, all repairs should be performed by a qualified service technician.

SAFETY INSTRUCTIONS

The purpose of safety symbols is to attract your attention to possible dangers. The safety symbols, and the explanations with them, deserve your careful attention and understanding. The symbol warnings do not, by themselves, eliminate any danger. The instructions and warnings they give are no substitutes for proper accident prevention measures.

 **WARNING:** Be sure to read and understand all safety instructions in this manual, including all safety alert symbols such as “DANGER,” “WARNING,” and “CAUTION” before using this tool. Failure to follow all instructions listed below may result in electric shock, fire, and/or serious personal injury.

SYMBOL MEANING



SAFETY ALERT SYMBOL: Indicates DANGER, WARNING, OR CAUTION. May be used in conjunction with other symbols or pictographs.



DANGER: Indicates an imminently hazardous situation, which, if not avoided, will result in death or serious injury.



WARNING: Indicates a potentially hazardous situation, which, if not avoided, could result in death or serious injury.



CAUTION: Indicates a potentially hazardous situation, which, if not avoided, could result in minor or moderate injury.

NOTICE: (Without Safety Alert Symbol) Indicates a situation that may result in property damage.

SAVE THESE INSTRUCTIONS!

SAFETY INSTRUCTIONS

GENERAL POWER TOOL SAFETY

WARNINGS

 **WARNING:** Read all safety warnings and all instructions. Failure to follow the warnings and instructions may result in electric shock, fire and/or serious injury.

Save all warnings and instructions for future reference.

The term “power tool” in the warnings refers to your mains-operated (corded) power tool or battery-operated (cordless) power tool.

WORK AREA SAFETY

1. Keep work area clean and well lit. Cluttered and dark areas invite accidents.
2. Do not operate power tools in explosive atmospheres, such as in the presence of flammable liquids, gases or dust. Power tools create sparks which may ignite the dust or fumes.
3. Keep children and bystanders away while operating a power tool. Distractions can cause you to lose control

ELECTRICAL SAFETY

1. Power tool plugs must match the outlet. Never modify the plug in any way. Do not use any adapter plugs with earthed (grounded) power tools. Unmodified plugs and matching outlets will reduce risk of electric shock.
2. Avoid body contact with earthed or grounded surfaces, such as pipes, radiators, ranges and refrigerators. There is an increased risk of electric shock if your body is earthed or grounded.
3. Do not expose power tools to rain or wet conditions. Water entering a power tool will increase the risk of electric shock.
4. Do not abuse the cord. Never use the cord for carrying, pulling or unplugging the power tool. Keep cord away from heat, oil, sharp edges or moving parts. Damaged or entangled cords increase the risk of electric shock.

5. When operating a power tool outdoors, use an extension cord suitable for outdoor use. Use of a cord suitable for outdoor use reduces the risk of electric shock.
6. If operating a power tool in a damp location is unavoidable, use a ground-fault circuit interrupter (GFCI) protected supply. Use of a GFCI reduces the risk of electric shock.

PERSONAL SAFETY

1. Stay alert, watch what you are doing and use common sense when operating a power tool. Do not use a power tool while you are tired or under the influence of drugs, alcohol or medication. A moment of inattention while operating power tools may result in serious personal injury.
2. Use personal protective equipment. Always wear eye protection. Protective equipment such as dust mask, non-skid safety shoes, hard hat, or hearing protection used for appropriate conditions will reduce personal injuries.
3. Prevent unintentional starting. Ensure the switch is in the off-position before connecting to power source and/or battery pack, picking up or carrying the tool. Carrying power tools with your finger on the switch or energising power tools that have the switch on invites accidents.
4. Remove any adjusting key or wrench before turning the power tool on. A wrench or a key left attached to a rotating part of the power tool may result in personal injury.
5. Do not overreach. Keep proper footing and balance at all times. This enables better control of the power tool in unexpected situations.
6. Dress properly. Do not wear loose clothing or jewellery. Keep your hair, clothing and gloves away from moving parts. Loose clothes, jewellery or long hair can be caught in moving parts.
7. If devices are provided for the connection of dust extraction and collection facilities, ensure that these are connected and properly used. Use of these devices can reduce dust-related hazards.

SAFETY INSTRUCTIONS

POWER TOOL USE AND CARE

1. Do not force the power tool. Use the correct power tool for your application. The correct power tool will do the job better and more safely at the rate for which it was designed.
2. Do not use the power tool if the switch does not turn it on and off. Any power tool that cannot be controlled with the switch is dangerous and must be repaired.
3. Disconnect the plug from the power source and/or the battery pack from the power tool before making any adjustments, changing accessories, or storing power tools. Such preventive safety measures reduce the risk of starting the power tool accidentally.
4. Store idle power tools out of the reach of children and do not allow persons unfamiliar with the power tool or these instructions to operate the power tool. Power tools are dangerous in the hands of untrained users.
5. Maintain power tools. Check for misalignment or binding of moving parts, breakage of parts and any other condition that may affect the power tool's operation. If damaged, have the power tool repaired before use. Many accidents are caused by poorly maintained power tools.
6. Keep cutting tools sharp and clean. Properly maintained cutting tools with sharp cutting edges are less likely to bind and are easier to control.
7. Use the power tool, accessories, tool bits, etc. in accordance with these instructions, taking into account the working conditions and the work to be performed. Use of the power tool for operations different from those intended could result in a hazardous situation.

BATTERY TOOL USE AND CARE

1. Recharge only with the charger specified by the manufacturer. A charger that is suitable for one type of battery pack may create a risk of fire when used with another battery pack.

2. Use power tools only with specifically designated battery packs. Use of any other battery packs may create a risk of injury and fire.
3. When battery pack is not in use, keep it away from other metal objects, like paper clips, coins, keys, nails, screws or other small metal objects, that can make a connection from one terminal to another. Shorting the battery terminals together may cause burns or a fire.
4. Under abusive conditions, liquid may be ejected from the battery; avoid contact. If contact accidentally occurs, flush with water. If liquid contacts eyes, additionally seek medical help. Liquid ejected from the battery may cause irritation or burns.

SERVICE

1. Have your power tool serviced by a qualified repair person using only identical replacement parts. This will ensure that the safety of the power tool is maintained.

SPECIFIC SAFETY RULES FOR RECIPROCATING SAW

1. Use battery only with charger listed below.

Battery pack	Charger
252-8024	252-8025
252-8029	252-8036
252-8030	252-8037
252-8031	252-8044
252-8032	
252-8033	
252-8034	
252-8035	

2. Hold power tool by insulated gripping surfaces, when performing an operation where the cutting accessory may contact hidden wiring. Cutting accessory contacting a "live" wire may make exposed metal parts of the power tool "live" and could give the operator an electric shock.

SAFETY INSTRUCTIONS

3. Use clamps or another practical way to secure and support the workpiece to a stable platform. Holding the work by your hand or against the body leaves it unstable and may lead to loss of control.
4. The saw blade must be securely locked in its holder. Check that it has been securely seated before use.
5. Make certain that all adjusting levers and the blade holder are tight before making a cut. Loose adjusting levers and holders can cause the tool or blade to slip; loss of control may result.
6. Check that the switch is "off" before attaching a battery. Accidental starting could cause injury.
7. Secure material before cutting. Never hold the workpiece in your hand or across your legs. Small or thin material may flex or vibrate with the blade, causing loss of control.
8. Never touch the saw blade immediately after use. It may be hot after prolonged use.
9. Always wear safety goggles or eye protection when using this tool. Use a dust mask or respirator if cutting generates a great amount of dust.
10. Keep hands away from the cutting area. Do not reach under the material being cut. The proximity of the blade to your hand is hidden from your sight.
11. Do not use dull or damaged saw blades and accessories.
12. When using the hook always be aware that the blade is exposed. Always hang the tool in an area where yourself and bystanders can not accidentally make contact with the blade.



WARNING: Some dust created by power sanding, sawing, grinding, drilling and other construction activities contains chemicals known to the state of California to cause cancer, birth defects or other reproductive harm. Some examples of these chemicals are:

- Lead from lead-based paints
- Crystalline silica from bricks and cement and other masonry products, and
- Arsenic and chromium from chemically-treated lumber.

Your risk from these exposures varies, depending on how often you do this type of work. To reduce your exposure to these chemicals: work in a well ventilated area, and work with approved safety equipment, such as those dust masks that are specially designed to filter out microscopic particles.

OVERVIEW

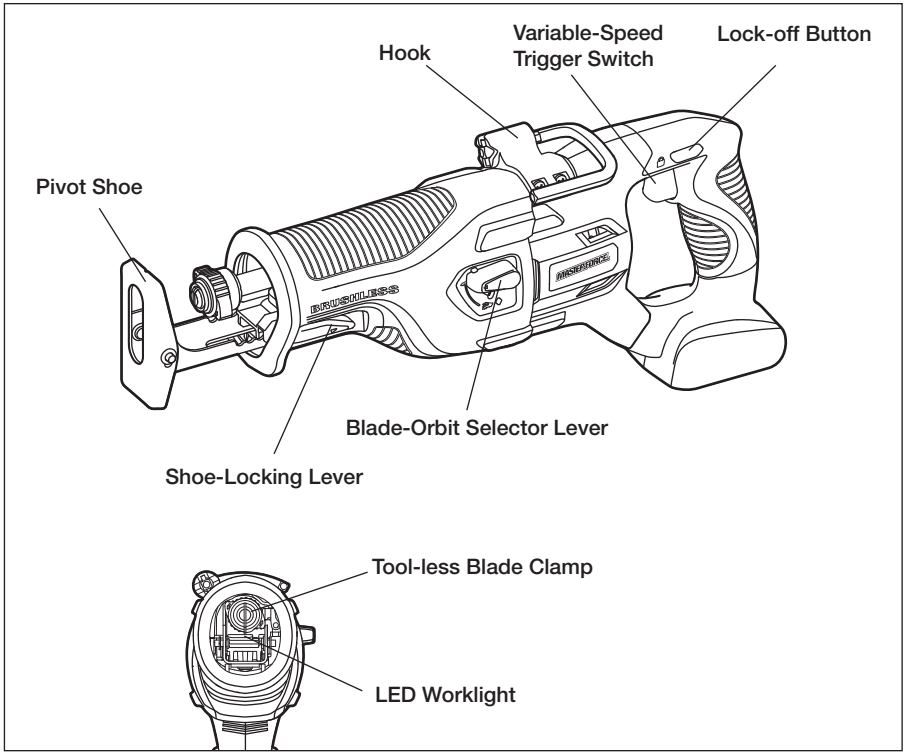

SPECIFICATIONS

No-load Speed	0-3,100 RPM
Blade Stroke	1-1/8" (29mm)
Tool Weight (without battery)	5 lb. 15 oz. (2.7 kg)

ASSEMBLY

WARNING: If any part is broken or missing, **DO NOT** attempt to plug in the power cord or operate the tool until the broken or missing part is replaced. Failure to do so could result in possible serious injury.

WARNING: Do not attempt to modify this tool or create accessories not recommended for use with this tool. Any such alteration or modification is misuse and could result in a hazardous condition leading to possible serious injury.

WARNING: Your tool should never be connected to the power source when you are assembling parts, making adjustments, installing or removing blades, cleaning, or when it is not in use. Disconnecting the tool will prevent accidental starting, which could cause serious personal injury.

CONTENTS

Reciprocating saw, 2 wood-cutting blades, instruction manual.

UNPACKING

1. Carefully remove the tool and any accessories from the carton. Make sure that all items listed in the packing list are included.
2. Inspect the tool carefully to make sure that no breakage or damage occurred during shipping.
3. Do not discard the packing material until you have carefully inspected and satisfactorily operated the tool.

TO ATTACH BATTERY PACK (FIG. 1)

1. Make sure that the tool is switched off.
2. Align the raised rib on the battery pack with the grooves on the bottom of the saw, and then slide the battery pack to the tool.

NOTICE: Make sure that the latch on the battery pack snaps into place and the battery pack is secured to the tool before operation.

TO DETACH BATTERY PACK (FIG. 1)

1. Make sure that the tool is switched off.
2. Depress the battery release buttons located on the front of the battery pack to release the battery pack.
3. Pull the battery pack out and remove it from the tool.

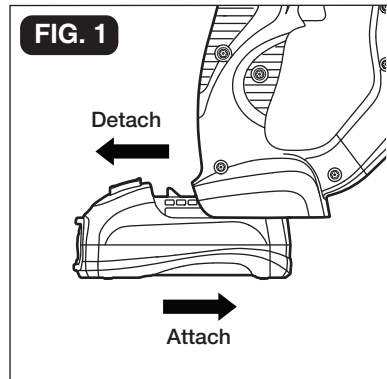

ASSEMBLY

INSTALLING THE BLADE (FIG. 2)

1. Remove the battery pack from the tool.
2. Turn the tool-less blade clamp counterclockwise.
3. Insert the blade into the slot in the blade clamp.
4. Release the blade clamp to lock the blade in place.

NOTICE: When changing a blade immediately after operation, allow the blade to cool before removing to avoid possible burning from the hot blade.

NOTICE: The blade may be installed with the teeth pointing up or down, according to the needs of the cutting operation. Note that orbital action is effective only when the saw blade teeth face down.

WARNING: For all work and when changing the blade, always wear protective gloves. The sharp edges of the blade will cause personal injury. The blade can become very hot while working.

REMOVING THE BLADES (FIG. 2)

1. Remove the battery pack from the tool.
2. Turn the tool-less blade clamp counterclockwise.
3. Pull the blade out of the blade clamp.

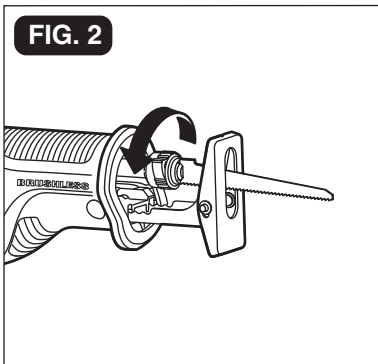

PIVOT SHOE (FIG. 3)

For maximum control and longer blade life,

the base assembly slides in or out to adjust the effective stroke length.

1. Remove the battery pack from the tool.
2. Pull the shoe-locking lever and slide the shoe to the desired position. The shoe can be locked in any position.
3. Push the shoe-locking lever to lock the shoe in the desired position.
4. Hold the saw firmly and then pivot the shoe to the desired angle.

WARNING: To avoid injury and damage, do not operate the saw without the pivot shoe in place. The spindle may strike against the workpiece and damage the reciprocating mechanism.

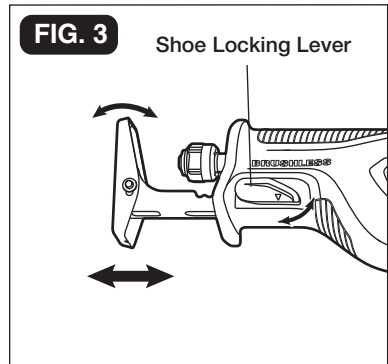

HOOK (FIG. 4)

Your tool is equipped with a convenient hook for hanging your tool. To use, simply lift up hook until it snaps into the open position. When not in use, always lower hook until it snaps into the closed position.

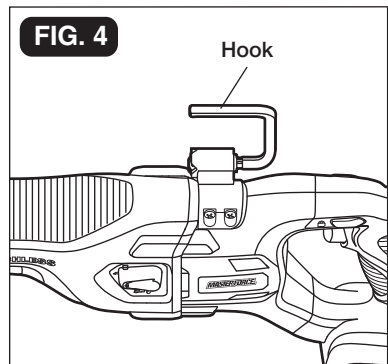

OPERATION

VARIABLE-SPEED TRIGGER SWITCH (FIG. 5A & 5B)

Your reciprocating saw is equipped with a trigger switch to turn the saw on and off and to control the speed.

1. Before you turn on the tool, open the lock-off button by pressing from the right side (FIG. 5A).

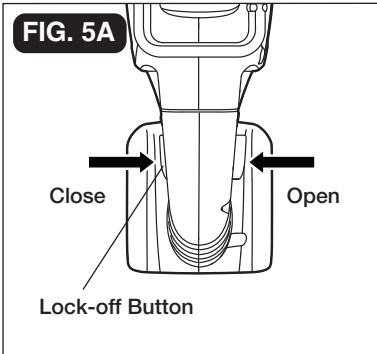

2. To turn the saw on, depress the trigger switch (FIG. 5B).

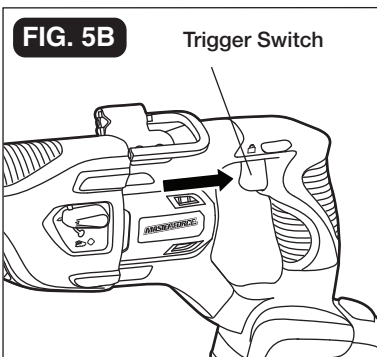

3. To turn the saw off, release the trigger switch.
4. The variable-speed trigger switch delivers higher speed with increased trigger pressure and lower speed with decreased trigger pressure.

NOTICE: Engage the lock-off button by pressing from the left side when the tool is not in use.

ADJUSTING THE BLADE ORBIT ACTION (FIG. 6)

This reciprocating saw has the option of orbit action to make the blade swing slightly as it cuts. Maximum cutting efficiency can be obtained by adjusting the blade orbit selector lever to orbital action.

1. Remove the battery pack from the tool.
2. Turn the orbit selection lever to the "Orbit" position for orbital cutting action.
3. Turn the orbit selection lever to the "Straight" position for straight cutting action.

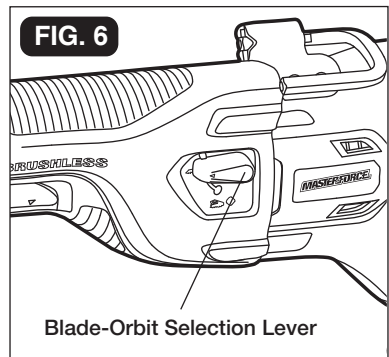

LED WORKLIGHT (FIG. 7)

Your reciprocating saw has two built-in LED worklights for illuminating the cutting area. To activate the LED worklight, open the lock-off button and depress the trigger switch. The light will automatically turn off within 10 seconds after releasing the trigger.

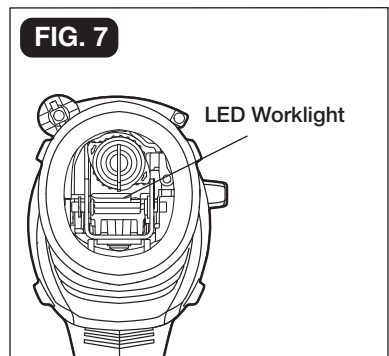

OPERATION

GENERAL CUTTING

WARNING: Before attaching the battery pack to the tool, always check to determine that the switch performs properly and returns to the "OFF" position when released.

WARNING: Hold the tool only by the plastic handle and the insulated grip area to help prevent electrical shock. When sawing into walls or floors you may encounter electrical wiring. Sawing into a "live" wire will cause electric shock.

1. Remove the battery pack from the saw.
2. Make sure that the workpiece is firmly clamped.
3. Use the appropriate type and size of blade for the workpiece material and size.
4. Adjust the pivot shoe as necessary to make sure that the blade will extend beyond the shoe and the workpiece at all times.
5. Adjust the pivot shoe as necessary to expose unworn blade teeth for longer blade life.
6. Check for clearance behind the workpiece so that the blade will not impact another surface.
7. Mark the line of cut clearly. If cutting metal, see METAL CUTTING section.
8. Attach the battery pack to the saw.
9. Hold the saw firmly with both hands. Make sure to keep your hands on the insulated gripping areas only.
10. Open the lock-off button and press the trigger switch to start the saw and bring it to the maximum desired cutting speed before applying the blade to the workpiece.
11. Do not force the tool. Place the shoe firmly on the workpiece while cutting. Use only enough steady pressure on the blade to keep the saw cutting.
12. Reduce pressure as the blade comes to the end of the cut.
13. Allow the saw to come to a complete stop before removing the blade from the workpiece.
14. If sawing fiberglass, plaster, wallboard, or spackling compound, clean the saw motor vents frequently with a vacuum or compressed air. These materials are highly abrasive and may accelerate the wear on motor bearings and brushes.

WARNING: Always wear safety goggles or safety glasses with side shields during power tool operations, or when blowing dust.

NOTICE: Cutting speeds should vary with the workpiece. Hard materials, such as metals, require lower speeds; for softer materials use higher speeds.

PLUNGE CUTTING (FIG. 8)

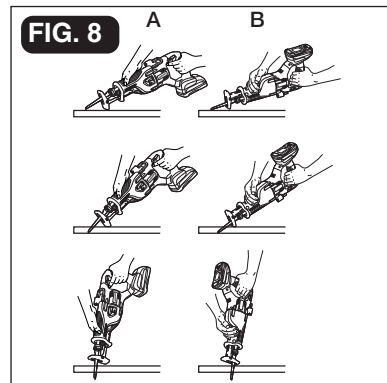

Your reciprocating saw is ideal for plunge cutting directly into surfaces that cannot be cut from an edge, such as walls or floors. Plunge cutting may be done two ways, depending on how the blade is inserted.

Column A shows how to plunge cut with the teeth of the blade facing down. Column B shows how to plunge cut with the teeth of the blade facing up.

1. Insert the blade into the tool. If the blade is inserted with the teeth facing downward, hold the tool as shown in Column A, resting the edge of the shoe on the workpiece.
2. If you inserted the blade with the teeth facing upward, hold the tool as shown in Column B, resting the edge of the shoe on the workpiece as shown.
3. With the blade just above the workpiece, depress the trigger switch, and using the edge of the shoe as a pivot, lower the blade into the workpiece.

OPERATION

4. As the blade starts cutting, raise the handle of the tool slowly until the shoe rests firmly on the workpiece.
5. After the blade has penetrated through the workpiece, guide the tool along your cutting line to achieve the desired cut.
6. Release the trigger switch. Do not remove the blade from the material until the blade has completely stopped moving.

NOTICE: To make plunge cutting easier, use a heavy gauge blade and install the blade with the teeth facing upward as show in column B (FIG. 8).

 **WARNING:** To reduce the risk of explosion, electric shock and property damage, always check the work area for hidden gas pipes, electrical wires or water pipes when making blind or plunge cut.

 **WARNING:** To avoid loss of control and serious injury, make sure that the blade reaches maximum speed before touching it to the workpiece.

 **WARNING:** Do not make plunge cuts in metal materials.

METAL CUTTING

The saw can be used to cut metals, such as sheet steel, pipe, steel rods, aluminum, brass, and copper. Be careful not to twist or bend the saw blade. Do not force.

The use of cutting oil is recommended when cutting soft metals and steel. Cutting oil will keep the blade cool, increase the cutting action, and prolong blade life.

 **WARNING:** Never use gasoline, because normal sparking could ignite the fumes.

1. Securely clamp the workpiece in position, and make the cut close to the clamping point in order to minimize vibration of the work being cut.
2. When cutting conduit pipe or angle iron, clamp the work in a vise, if possible, and cut close to the vise.
3. To cut thin sheet material, “sandwich” the material between pieces of hardboard or plywood, and clamp the layers together in order to reduce vibration and tearing of the material.

MAINTENANCE

 **WARNING:** Always wear safety goggles or safety glasses with side shields during power tool operations, or when blowing dust. If operation is dusty, also wear a dust mask.

 **WARNING:** Do not at any time let brake fluids, gasoline, petroleum-based products, penetrating oils, etc. come in contact with plastic parts. Chemicals can damage, weaken or destroy plastic, which may result in serious personal injury.

MAINTENANCE

The tool may be cleaned most effectively with compressed dry air. Always wear safety goggles when cleaning tools with compressed air.

Avoid using solvents when cleaning plastic parts. Most plastics are susceptible to damage from various types of commercial solvents and may be damaged by their use. Use clean cloths to remove dirt, dust, oil, grease, etc.

MAINTENANCE

BEFORE EACH USE

1. Inspect the reciprocating saw, the on/off switch and the accessories for damage.
2. Check for damaged, missing, or worn parts.
3. Check for loose screws, misalignment or binding of moving parts, or any other condition that may affect the operation.
4. If abnormal vibration or noise occurs, turn the tool off immediately and have the problem corrected before further use.
5. Detach the battery from the saw before cleaning or performing any maintenance. Using compressed air may be the most effective cleaning method. Always wear safety goggles when cleaning tools using compressed air.

LUBRICATION

All of the bearings in this tool are lubricated with a sufficient amount of high grade lubricant for the life of the unit under normal conditions. Therefore, no further lubrication is required.

TROUBLESHOOTING

PROBLEM	CAUSE	SOLUTION
The saw does not work.	The battery is depleted.	Charge the battery.
The saw does not work and the tool LED worklight flashes.	The tool is overheated.	Cool down the tool.
The saw does not work and two battery pack LED lights alternately flash.	The battery is overheated.	Cool down the battery.
The saw does not work and the battery pack LED lights flash.	The battery is in overloaded protection.	Load appropriate loading force when cutting with the saw.
Cutting is difficult.	Saw blade is wore out.	Replace the saw blade.



BRUSHLESS RECIPROCATING SAW WARRANTY

90-DAY MONEY BACK GUARANTEE:

This MASTERFORCE® brand power tool carries our 90-DAY Money Back Guarantee. If you are not completely satisfied with your MASTERFORCE® brand power tool for any reason within ninety (90) days from the date of purchase, return the tool with your original receipt to any MENARDS® retail store, and we will provide you a refund – no questions asked.

3-YEAR LIMITED WARRANTY:

This MASTERFORCE® brand power tool carries our famous No Hassle 3-Year Limited Warranty to the original purchaser. If, during normal use, this MASTERFORCE® power tool breaks or fails due to a defect in material or workmanship within three (3) years from the date of original purchase, simply bring this tool with the original sales receipt back to your nearest MENARDS® retail store. At its discretion, MASTERFORCE® agrees to have the tool or any defective part(s) repaired or replaced with the same or similar MASTERFORCE® product or part free of charge, within the stated warranty period, when returned by the original purchaser with original sales receipt. Notwithstanding the foregoing, this limited warranty does not cover any damage that has resulted from abuse or misuse of the Merchandise. This warranty: (1) excludes expendable parts including but not limited to blades, brushes, belts, bits, light bulbs, and/or batteries; (2) shall be void if this tool is used for commercial and/or rental purposes; and (3) does not cover any losses, injuries to persons/property or costs. This warranty does give you specific legal rights and you may have other rights, which vary from state to state. Be careful, tools are dangerous if improperly used or maintained. Seller's employees are not qualified to advise you on the use of this Merchandise. Any oral representation(s) made will not be binding on seller or its employees. The rights under this limited warranty are to the original purchaser of the Merchandise and may not be transferred to any subsequent owner. This limited warranty is in lieu of all warranties, expressed or implied including warranties or merchantability and fitness for a particular purpose. Seller shall not be liable for any special, incidental, or consequential damages. The sole exclusive remedy against the seller will be for the replacement of any defects as provided herein, as long as the seller is willing or able to replace this product or is willing to refund the purchase price as provided above. For insurance purposes, seller is not allowed to demonstrate any of these power tools for you.

For questions / comments, technical assistance or repair parts – Please Call Toll Free: 1-866-917-4374 (M-F 8:30am-5:00pm EST).

**SAVE YOUR RECEIPTS
THIS WARRANTY IS VOID WITHOUT THEM**

MASTER★FORCE®

MENARDS®



Area Light

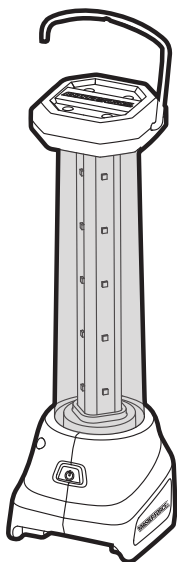

241-0494

OPERATOR'S MANUAL

⚠ CAUTION: To Reduce The Risk Of Injury, User Must Read And Understand Operator's Manual. Save These Instructions For Future Reference.



For questions / comments, technical assistance or repair parts –
Please Call Toll Free: 1-866-917-4374(M-F 8:30am-5:00pm EST).

TABLE OF CONTENTS

Safety Symbols	Page 2
Safety Instructions	Page 3
Overview/Specifications	Page 5
Assembly	Page 6
Operation/Maintenance	Page 7
Troubleshooting	Page 8
Warranty	Page 12

SAFETY SYMBOLS

Some of these following symbols may be used on this tool. Please study them and learn their meaning. Proper interpretation of these symbols will allow you to operate the tool better and more safely.

Symbol	Name	Designation / Explanation
V	Volts	Voltage
A	Amperes	Current
Hz	Hertz	Frequency (cycles per second)
W	Watts	Power
~	Alternating current	Type of current
—	Direct current	Type or characteristic of current
n_o	No-load speed	Rotational speed at no load
lbs	Pounds	Weight
	Class II construction	Double insulated construction
.../min	Per minute	Revolutions, strokes, surface speed orbits, etc., per minute
	Wear safety goggles	 WARNING: The operation of any power tool can result in foreign objects being thrown into your eyes, which can result in severe eye damage. Before beginning power tool operation, always wear safety goggles or safety glasses with side shields and a full-face shield when needed. We recommend a Wide Vision Safety Mask for use over eye-glasses or standard safety glasses with side shields. Always use eye protection which is marked to comply with ANSI Z87.1.

 **WARNING:** To ensure safety and reliability, all repairs should be performed by a qualified service technician.

SAFETY INSTRUCTIONS

The purpose of safety symbols is to attract your attention to possible dangers. The safety symbols, and the explanations with them, deserve your careful attention and understanding. The symbol warnings do not, by themselves, eliminate any danger. The instructions and warnings they give are no substitutes for proper accident prevention measures.

 **WARNING:** Be sure to read and understand all safety instructions in this manual, including all safety alert symbols such as “DANGER”, “WARNING” and “CAUTION” before using this tool. Failure to following all instructions listed below may result in electric shock, fire, and/or serious personal injury.

SYMBOL MEANING



SAFETY ALERT SYMBOL: Indicates DANGER, WARNING, OR CAUTION.
May be used in conjunction with other symbols or pictographs.



DANGER: Indicates an imminently hazardous situation, which, if not avoided, will result in death or serious injury.



WARNING: Indicates a potentially hazardous situation, which, if not avoided, could result in death or serious injury.



CAUTION: Indicates a potentially hazardous situation, which, if not avoided, could result in minor or moderate injury.

NOTICE: (Without Safety Alert Symbol) Indicates a situation that may result in property damage.

SAVE THESE INSTRUCTIONS!

SAFETY INSTRUCTIONS

GENERAL POWER TOOL SAFETY WARNINGS

 **WARNING:** Read all safety warnings and all instructions. Failure to follow the warnings and instructions may result in electric shock, fire and/or serious injury.

Save all warnings and instructions for future reference.

The term “power tool” in the warnings refers to your mains-operated (corded) power tool or battery-operated (cordless) power tool.

 **WARNING:** When using electric appliances, basic precautions should always be followed, including the following:

1. Read all the instructions before using the appliance.
2. To reduce the risk of injury, close supervision is necessary when an appliance is used near children.
3. Do not contact moving parts.
4. Only use attachments recommended or sold by the manufacturer.
5. To reduce the risk of electric shock or damage to the charger and battery, use only the batteries and charger listed.

Battery pack	Charger
252-8024	252-8025
252-8029	252-8036
252-8030	252-8037
252-8031	252-8044
252-8032	
252-8033	
252-8034	
252-8035	

6. The lens gets very hot during use. To reduce the risk of burns, do not touch hot lens.
7. To reduce the risk of fire, keep away from combustible materials while in operation.

8. Recharge only with the charger specified by the manufacturer. A charger that is suitable for one type of battery pack may create a risk of fire when used with another battery pack.

9. Use power tools only with specifically designated battery packs. Use of any other battery packs may create a risk of injury and fire.

10. When battery pack is not in use, keep it away from other metal objects like paper clips, coins, keys, nails screws or other small metal objects that can make a connection from one terminal to another. Shorting the battery terminals together may cause burns or a fire.

11. Under abusive conditions, liquid may be ejected from the battery; avoid contact. If contact accidentally occurs, flush with water. If liquid contacts eyes, also seek medical help. Liquid ejected from the battery may cause irritation or burns.

12. Have your power tool serviced by a qualified repair person using only identical replacement parts. This will ensure that the safety of the power tool is maintained

13. Do not use outdoor. This worklight is intended for household use only. Using it outdoor may increase the risk of electric shock or fire.

14. Do not wash the worklight with water nor keep in a damp location. If the worklight gets wet, dry it off as soon as possible.

15. To reduce the risk of electrical shock, do not put the unit in water or other liquid.

16. Do not place or store unit where it can fall or be pulled into a tub or sink.

17. Do not work with the cordless worklight in hazardous areas.

18. Do not use the cordless worklight in road traffic. The cordless worklight is not approved for illumination in road traffic.

19. Remove the battery from the cordless worklight before any work on the cordless worklight itself (e.g. assembling, maintenance, cleaning, etc.), as well as when transporting and storing.

20. Do not allow children to use the cordless worklight. It is intended for professional use. Children can unintentionally blind themselves or other persons.

OVERVIEW

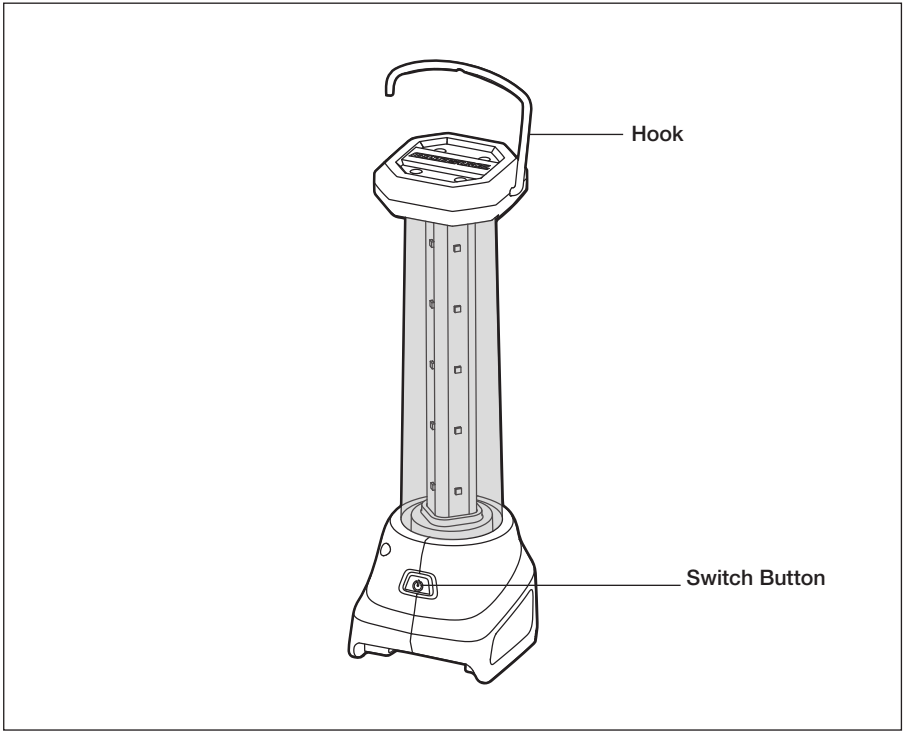

SPECIFICATIONS

Numbers of LED		20
Light Output (at 360°high brightness)		850 Lumens
3 Modes	360° illumination, 2 brightness levels	High
		Low
	180° illumination	
Area Light Weight (without battery)		1 lb. (0.44 kg)

ASSEMBLY

WARNING: If any part is broken or missing, **DO NOT** attempt to attach the battery or operate the tool until the broken or missing part is replaced. Failure to do so could result in possible serious injury.

WARNING: Do not attempt to modify this tool or create accessories not recommended for use with this tool. Any such alteration or modification is misuse and could result in a hazardous condition leading to possible serious injury.

WARNING: Your tool should never be connected to the battery when you are assembling parts, making adjustments, installing or removing blades, cleaning, or when it is not in use. Disconnecting the tool will prevent accidental starting, which could cause serious personal injury.

CONTENTS

Cordless LED area light, instruction manual.

UNPACKING

1. Carefully remove the light and any accessories from the carton. Make sure that all items listed in the packing list are included.
2. Inspect the light carefully to make sure that no breakage or damage occurred during shipping.
3. Do not discard the packing material until you have carefully inspected and satisfactorily operated the light.

TO ATTACH BATTERY PACK (FIG. 1)

Align the raised rib on the battery pack with the grooves on the bottom of the light, and then slide the battery pack to the light.

NOTICE: Make sure that the latch on the battery pack snaps into place and the battery pack is secured to the light before operation.

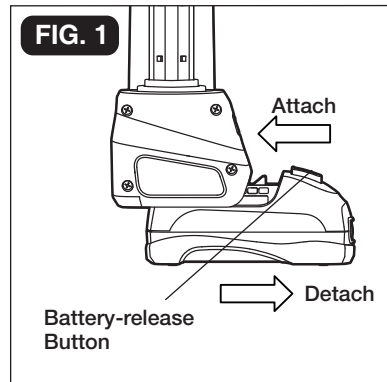

TO DETACH BATTERY PACK (FIG. 1)

1. Make sure that the light is switched off.
2. Depress the battery-release buttons located on the front of the battery pack to release the battery pack.
3. Pull the battery pack out and remove it from the light.

OPERATION

TURNING THE AREA LIGHT ON AND OFF (FIG. 2)

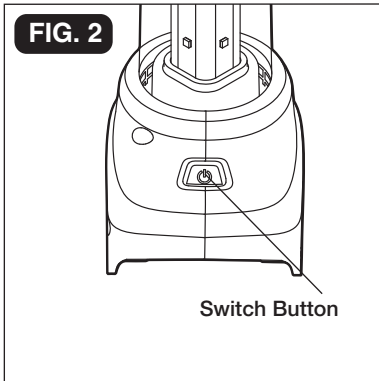

1. Press the switch: the light is on at 360° high illumination mode.
2. Press the switch again: the light is on at 360° low illumination mode.
3. Press the switch button a third time and the light will produce 180° illumination.
4. Press the switch again to turn the light is off.

UTILITY HOOK

Your light is equipped with a convenient utility hook for hanging your light. To use, simply lift the hook until it snaps into the open position. When not in use, always lower hook until it snaps into the closed position.

MAINTENANCE

⚠ WARNING: Do not at any time let brake fluids, gasoline, petroleum-based products, penetrating oils, etc. come in contact with plastic parts. Chemicals can damage, weaken or destroy plastic, which may result in serious personal injury.

MAINTENANCE

The tool may be cleaned most effectively with compressed dry air. Always wear safety goggles when cleaning tools with compressed air.

Avoid using solvents when cleaning plastic parts. Most plastics are susceptible to damage from various types of commercial solvents and may be damaged by their use. Use a clean cloth to remove dirt, dust, oil, grease, etc.

BEFORE EACH USE

1. Check for damaged, missing, or worn parts.
2. Check for loose screws, misalignment or binding of moving parts, or any other condition that may affect the operation.
3. If abnormal vibration or noise occurs, turn the tool off immediately and have the problem corrected before further use.

TROUBLESHOOTING

PROBLEM	CAUSE	SOLUTION
The light does not work.	The battery is depleted.	Charge the battery.



Area Light WARRANTY

90-DAY MONEY BACK GUARANTEE:

This MASTERFORCE® brand power tool carries our 90-DAY Money Back Guarantee. If you are not completely satisfied with your MASTERFORCE® brand power tool for any reason within ninety (90) days from the date of purchase, return the tool with your original receipt to any MENARDS® retail store, and we will provide you a refund – no questions asked.

3-YEAR LIMITED WARRANTY:

This MASTERFORCE® brand power tool carries our famous No Hassle 3-Year Limited Warranty to the original purchaser. If, during normal use, this MASTERFORCE® power tool breaks or fails due to a defect in material or workmanship within three (3) years from the date of original purchase, simply bring this tool with the original sales receipt back to your nearest MENARDS® retail store. At its discretion, MASTERFORCE® agrees to have the tool or any defective part(s) repaired or replaced with the same or similar MASTERFORCE® product or part free of charge, within the stated warranty period, when returned by the original purchaser with original sales receipt. Notwithstanding the foregoing, this limited warranty does not cover any damage that has resulted from abuse or misuse of the Merchandise. This warranty: (1) excludes expendable parts including but not limited to blades, brushes, belts, bits, light bulbs, and/or batteries; (2) shall be void if this tool is used for commercial and/or rental purposes; and (3) does not cover any losses, injuries to persons/property or costs. This warranty does give you specific legal rights and you may have other rights, which vary from state to state. Be careful, tools are dangerous if improperly used or maintained. Seller's employees are not qualified to advise you on the use of this Merchandise. Any oral representation(s) made will not be binding on seller or its employees. The rights under this limited warranty are to the original purchaser of the Merchandise and may not be transferred to any subsequent owner. This limited warranty is in lieu of all warranties, expressed or implied including warranties or merchantability and fitness for a particular purpose. Seller shall not be liable for any special, incidental, or consequential damages. The sole exclusive remedy against the seller will be for the replacement of any defects as provided herein, as long as the seller is willing or able to replace this product or is willing to refund the purchase price as provided above. For insurance purposes, seller is not allowed to demonstrate any of these power tools for you.

For questions / comments, technical assistance or repair parts – Please Call Toll Free: 1-866-917-4374(M-F 8:30am-5:00pm EST).

**SAVE YOUR RECEIPTS
THIS WARRANTY IS VOID WITHOUT THEM**

MASTER★FORCE®

MENARDS®