

# Owner's Manual & Safety Instructions

**Save This Manual** Keep this manual for the safety warnings and precautions, assembly, operating, inspection, maintenance and cleaning procedures. Write the product's serial number in the back of the manual near the assembly diagram (or month and year of purchase if product has no number). Keep this manual and the receipt in a safe and dry place for future reference.

## ***2000 lb. Capacity Low-Profile Transmission Jack***

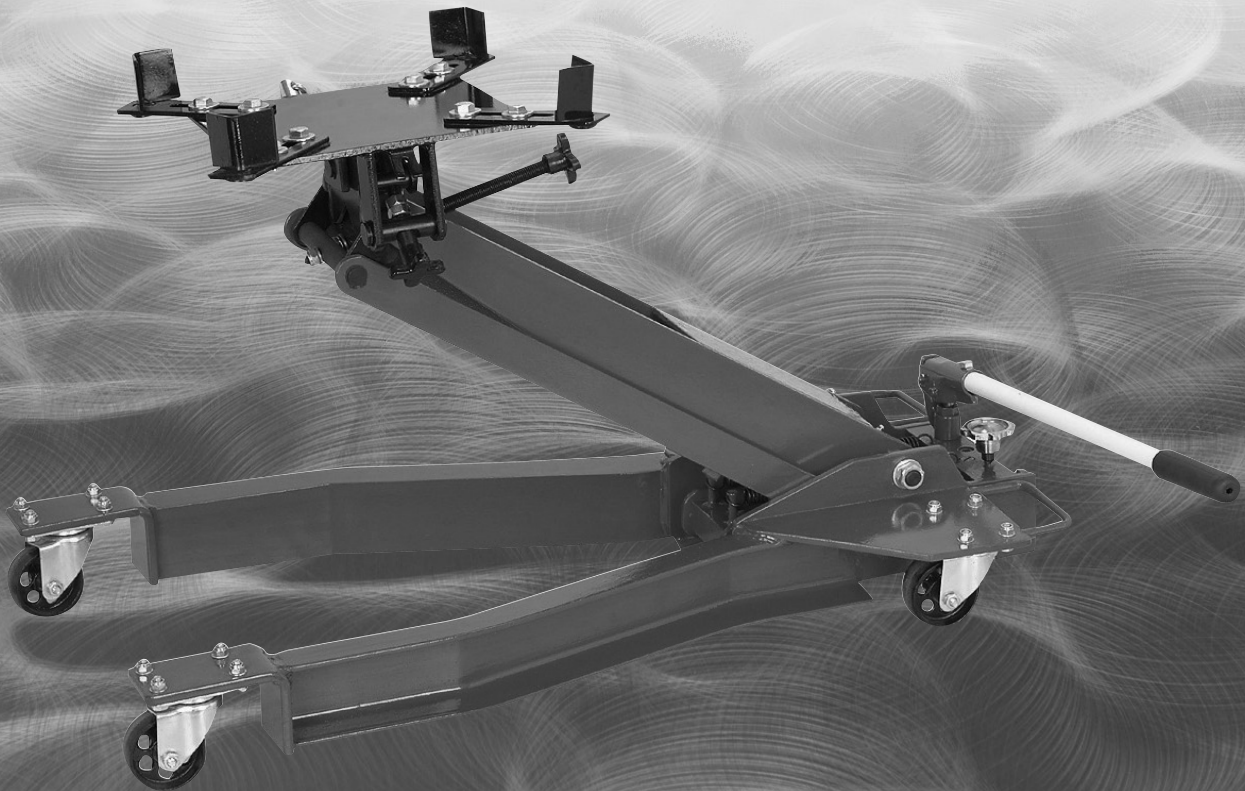

Model # 261-3337

**MAXWORKS**™

### **⚠ WARNING**





Read this material before using this product.  
Failure to do so can result in serious injury.  
**SAVE THIS MANUAL.**

## Specifications

Weight Capacity	2000 lb.
Tilt	55° forward, 10° back, 12° side

Maximum Height	30-3/4"
Minimum Height	6-3/4"

### WARNING SYMBOLS AND DEFINITIONS

	This is the safety alert symbol. It is used to alert you to potential personal injury hazards. Obey all safety messages that follow this symbol to avoid possible injury or death.
	Indicates a hazardous situation which, if not avoided, will result in death or serious injury.
	Indicates a hazardous situation which, if not avoided, could result in death or serious injury.
	Indicates a hazardous situation which, if not avoided, could result in minor or moderate injury.
	Addresses practices not related to personal injury.

## IMPORTANT SAFETY INFORMATION

### WARNING

Read all safety warnings and instructions.

Save all warnings and instructions for future reference.

Failure to heed these markings may result in personal injury and/or property damage:

1. Study, understand, and follow all instructions before operating this device.
2. Do not exceed 2000 lb. rated capacity.
3. Use only on hard, level surfaces.
4. Adequately support the vehicle before starting repairs.
5. Use of this product is limited to the removal, installation, and transportation in the lowered position, of transmissions, transfer cases, and transaxles.
6. Do not adjust safety valve.
7. Wear ANSI-approved safety goggles and heavy-duty work gloves during use.
8. Keep clear of load while lifting and lowering.
9. Lower load slowly.
10. Do not use for aircraft purposes.
11. Inspect before every use; do not use if parts loose or damaged.
12. Do not alter the jack or use attachments and/or adapters that are not supplied by the manufacturer.
13. The warnings, precautions, and instructions discussed in this manual cannot cover all possible conditions and situations that may occur. The operator must understand that common sense and caution are factors, which cannot be built into this product, but must be supplied by the operator.
14. The brass components of this product contain lead, a chemical known to the State of California to cause cancer, birth defects (or other reproductive harm). (California Health & Safety Code § 25249.5, *et seq.*)



**SAVE THESE INSTRUCTIONS.**

## Setup



Read the **ENTIRE IMPORTANT SAFETY INFORMATION** section at the beginning of this manual including all text under subheadings therein before set up or use of this product.

### **WARNING**

**TO PREVENT SERIOUS INJURY:**

Remove load from the jack before any procedure on this page.

**Note:** For additional information regarding the parts listed in the following pages, refer to *Parts List and Diagram* on page 7.

## Assembly

---

Connect a Support (16) to each corner of the Saddle (12) using a Bolt (14) and Washer (15).

## Checking/Filling Hydraulic Fluid

---

### **IMPORTANT! Before first use:**

1. Remove the Oil Fill Plug from top of Hydraulic Ram.
2. Check hydraulic oil level and fill to 1/4" below the fill port as needed.
3. Replace the Oil Fill Plug in top of Hydraulic Ram.
4. Thoroughly test the Jack for proper operation. If it does not work properly, bleed air from its hydraulic system as described in Bleeding, below.

## Bleeding

---

1. Follow the Checking/Filling Hydraulic Fluid instructions above.
2. Turn the Release Valve counterclockwise to open it.
3. Pump the Handle up and down quickly several times to purge air from the system.
4. Check hydraulic oil level and fill to 1/4" below the fill port as needed.
5. Replace the Oil Fill Plug and close the Release Valve by turning it clockwise.

# Functions

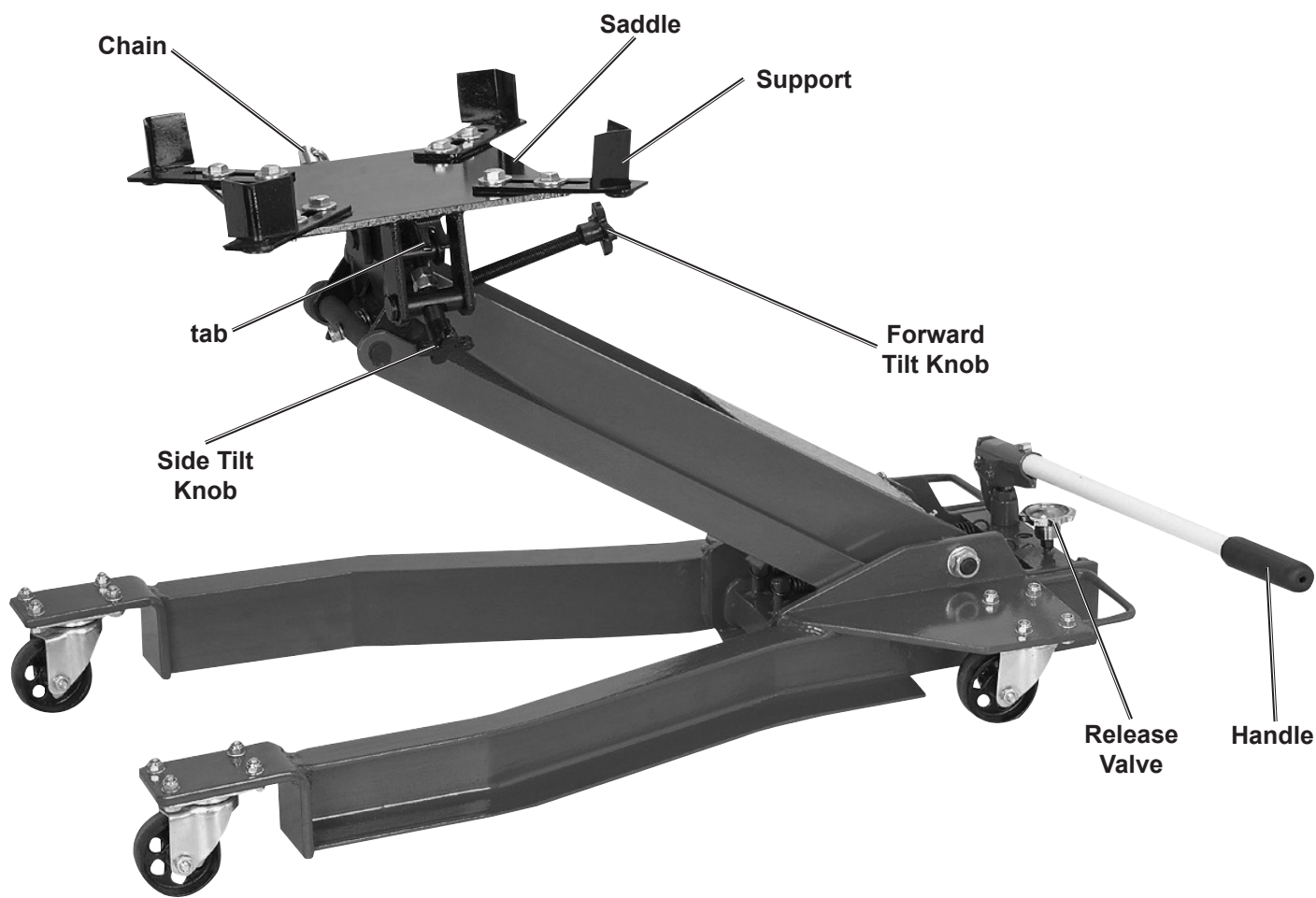



Read **ENTIRE IMPORTANT SAFETY INFORMATION** section at beginning of this manual including all text under subheadings therein before set up or use of this product.

## Removing a Transmission

---

1. Before every use, check and/or fill Hydraulic Fluid.
2. Once the vehicle is raised and secured on a lift, clear the area underneath the vehicle of people and tools.
3. Disconnect one end of the Chain and allow it to hang down.
4. Move the Transmission Jack underneath the transmission.
5. Close the Release Valve.
6. Pump the Handle to raise the Transmission Jack.
7. Stop just below the transmission and align the Saddle to the Transmission with the Tilt Knobs.
8. Continue raising the Saddle up to the transmission to determine where you will need to adjust the Supports. All four Supports need to grip and make contact with the transmission.
9. After determining where they need to be set, loosen the threaded bolts on each Support, and adjust it to the proper setting for the transmission. Tighten the bolts.
10. Raise the unit again to make contact with the transmission, making sure all of the Supports are in firm contact.
11. Wrap the Chain securely around the transmission, and hook the Chain to the bracket on the other side of the saddle.
12. Once it is securely fastened, release the bolts holding the transmission in place.
13. Make sure the area is clear of people and tools, and verify that the transmission is securely held in place. Then, slowly open the Release Valve to lower the Transmission Jack.
14. Move the Transmission Jack from under the vehicle and perform your desired maintenance.

## Replacing a Transmission

---

1. Move the Transmission Jack so that the transmission is lined up properly with its connection points.
2. Close the Release Valve.
3. Pump the Handle to gradually raise the Transmission Jack, while guiding it into place.
4. Secure the transmission into place using its hardware.
5. Double-check to make sure the transmission is securely installed.
6. Disconnect one end of the Chain and allow it to hang down.
7. Clear the area near the Transmission Jack, and slowly open the Release Valve to lower the Jack.
8. Move the Transmission Jack clear of the vehicle.

## Maintenance and Servicing



Procedures not specifically explained in this manual must be performed only by a qualified technician.

### ⚠️ WARNING

#### TO PREVENT SERIOUS INJURY FROM TOOL FAILURE:

Do not use damaged equipment. If abnormal noise or vibration occurs, have the problem corrected before further use.

1. **BEFORE EACH USE**, inspect the general condition of the equipment. Check for:
  - loose hardware,
  - misalignment or binding of moving parts,
  - visibly leaking hydraulic fluid,
  - cracked or broken parts, and
  - any other condition that may affect its safe operation.
2. **Before each use and after the inspection, thoroughly test the Jack for proper operation prior to its actual use.**  
**If the Jack appears *not* to be working properly, follow *Bleeding* instructions on page 3.**
3. **Change the hydraulic oil at least once every three years:**
  - a. With the Jack fully lowered, remove the Oil Fill Plug on the side of the Hydraulic Ram.
  - b. Tip the Jack to allow the old hydraulic oil to drain out of the Hydraulic Ram completely, and dispose of the old hydraulic oil in accordance with local regulations.
  - c. With the Jack upright, completely fill the Hydraulic Ram with a high quality hydraulic oil (not included) until the oil just begins to run out of the Oil Fill Hole.
  - d. Open the Release Valve and pump the Handle to bleed air from the system.
  - e. Reinstall the Oil Filler Plug.
4. Wipe dry with a clean cloth.  
 Then, store the Jack in a safe, dry location out of reach of children and other non-authorized people.

## Troubleshooting

### ⚠️ WARNING

**TO PREVENT SERIOUS INJURY: Use caution when troubleshooting malfunctioning jack.**

**Stay clear of supported load. Completely resolve all problems before use.**

If solutions presented in Troubleshooting guide do not solve the problem, have a qualified technician inspect and repair jack before use. **After jack is repaired: Test it carefully without a load by raising and lowering it fully, checking for proper operation, BEFORE RETURNING JACK TO OPERATION.**

**DO NOT USE A DAMAGED OR MALFUNCTIONING JACK!**

POSSIBLE SYMPTOMS						PROBABLE SOLUTION (Make certain that the Jack is not supporting a load while attempting a solution.)
Jack will not lift at its weight capacity	Saddle lowers under load	Pump stroke feels spongy	Saddle will not lift all the way	Handle moves up when Jack is under load	Oil leaking from Filler Plug	
X	X					Check that Release Valve is closed fully. Bleed air from the system.
X	X			X		Valves may be blocked and may not close fully. To flush the valves: 1. Lower the Saddle and securely close the Release Valve. 2. Manually lift the Saddle several inches. 3. Open the release valve and force the Saddle down as quickly as possible.
X		X	X			Jack may be low on oil. Check the oil level and refill if needed. Jack may require bleeding - see instructions on page 3.
					X	Unit may have too much hydraulic oil inside, check fluid level and adjust if needed.

# Parts List and Diagram

Part	Description	Qty	Part	Description	Qty	Part	Description	Qty
1	Base Frame	1	17	Hook	1	33	Oil Nozzle	1
2	Lifting Arm	1	18	Shaft	1	34	Split Pin	1
3	Long Connecting Bar	2	19	Washer 8	2	35	Hydraulic Ram	1
4	Short Connecting Bar	2	20	Wing Nut M8	1	36	Release Valve	1
5	Retaining Ring 18	8	21	Nut M8	1	37	Handle	1
6	Side Tilt Knob	1	22	Shaft	1	38	Bolt M12x30	2
7	Bushing	1	23	Bracket	1	39	Spring Washer 12	2
8	Shaft	1	24	Shaft	1	40	3" Swivel Caster	4
9	Nut M12	2	25	Lock Nut M10	1	41	Bolt M8x20	8
10	Shaft	1	26	Bearing 8101	2	42	Nut M16	2
11	Retaining Ring 22	2	27	Shaft	1	43	Washer 16	2
12	Saddle	1	28	Shaft	1	44	Shaft	1
13	Chain	1	29	Spring Pin 4*28	2	45	Bolt M8x25	8
14	Bolt M10x20	8	30	Forward Tilt Knob	1	46	Washer 8	16
15	Large Washer 10	8	31	Bolt M8x20	1	47	Lock Nut M8	16
16	Support	4	32	Spring	2			

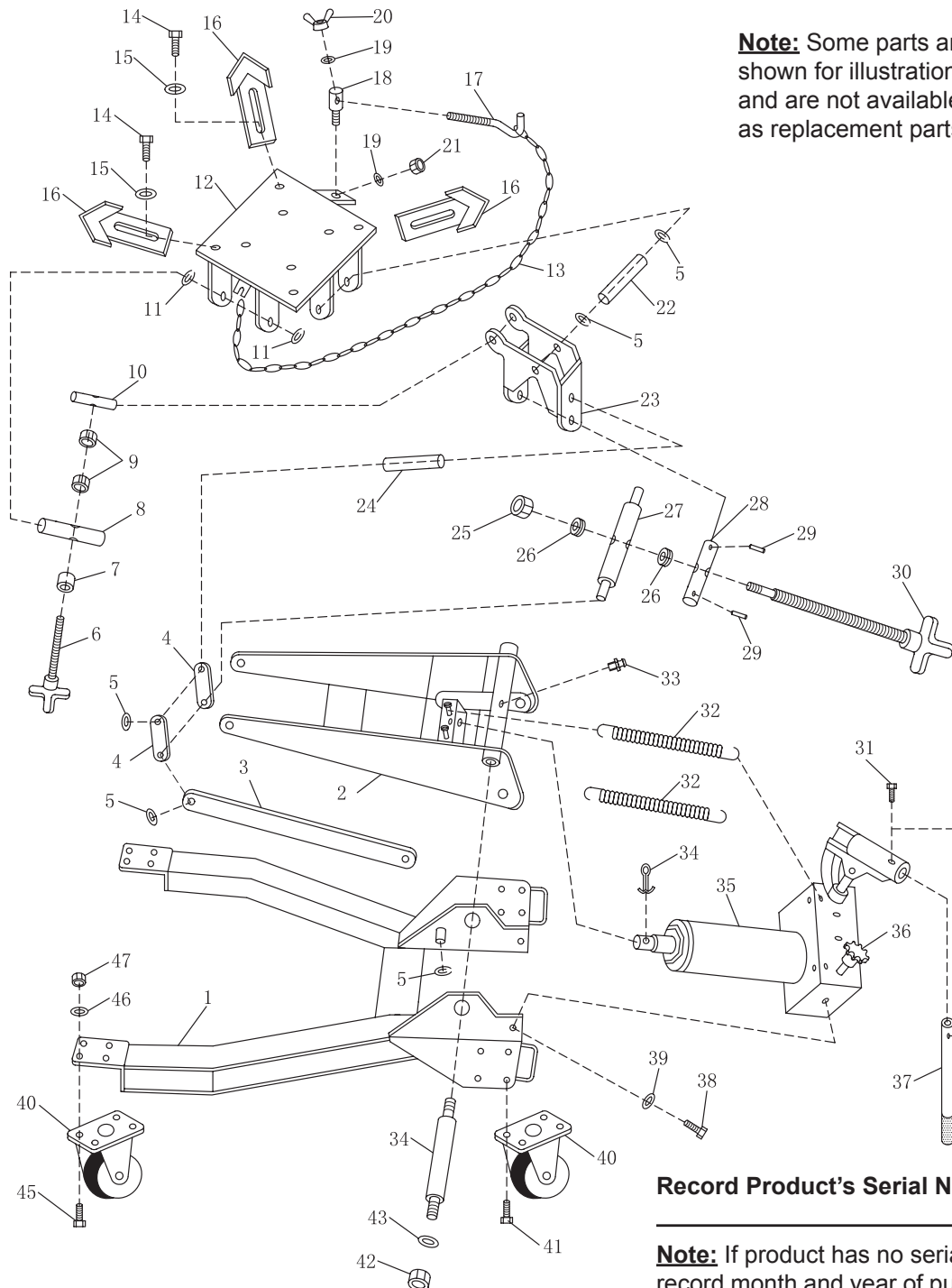

**Note:** Some parts are listed and shown for illustration purposes only, and are not available individually as replacement parts.

**Record Product's Serial Number Here:**

---

**Note:** If product has no serial number, record month and year of purchase instead.

## **PLEASE READ THE FOLLOWING CAREFULLY**

---

THE MANUFACTURER AND/OR DISTRIBUTOR HAS PROVIDED THE PARTS LIST AND ASSEMBLY DIAGRAM IN THIS MANUAL AS A REFERENCE TOOL ONLY. NEITHER THE MANUFACTURER OR DISTRIBUTOR MAKES ANY REPRESENTATION OR WARRANTY OF ANY KIND TO THE BUYER THAT HE OR SHE IS QUALIFIED TO MAKE ANY REPAIRS TO THE PRODUCT, OR THAT HE OR SHE IS QUALIFIED TO REPLACE ANY PARTS OF THE PRODUCT. IN FACT, THE MANUFACTURER AND/OR DISTRIBUTOR EXPRESSLY STATES THAT ALL REPAIRS AND PARTS REPLACEMENTS SHOULD BE UNDERTAKEN BY CERTIFIED AND LICENSED TECHNICIANS, AND NOT BY THE BUYER. THE BUYER ASSUMES ALL RISK AND LIABILITY ARISING OUT OF HIS OR HER REPAIRS TO THE ORIGINAL PRODUCT OR REPLACEMENT PARTS THERETO, OR ARISING OUT OF HIS OR HER INSTALLATION OF REPLACEMENT PARTS THERETO.