

MASTERFORCE®

STRAIGHT FINISH NAILER

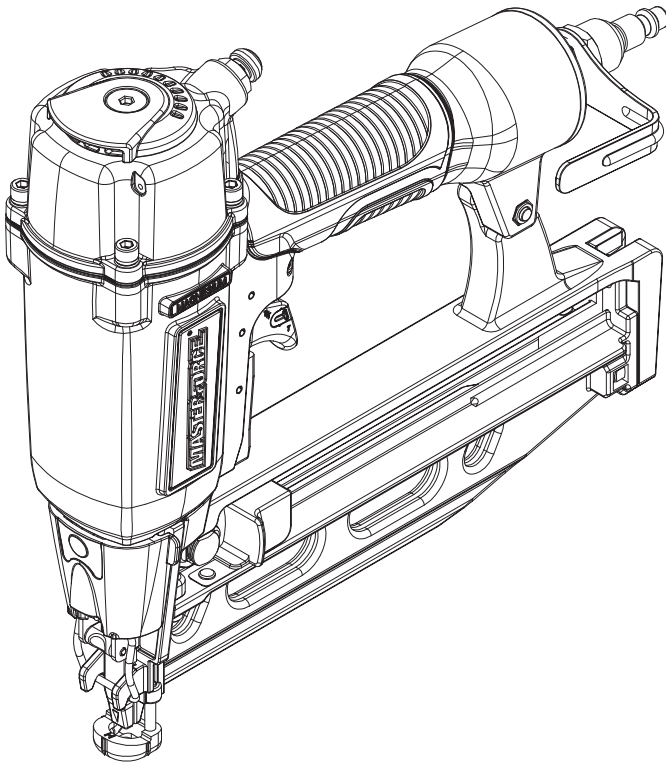

208-5007

OPERATOR'S MANUAL

⚠ CAUTION: TO REDUCE THE RISK OF INJURY, USER MUST READ AND UNDERSTAND OPERATOR'S MANUAL. SAVE THESE INSTRUCTIONS FOR FUTURE REFERENCE.

TABLE OF CONTENTS

Safety Instructions	Page 2
Air Supply: Fittings, Hoses, Filters, Air Consumption, Regulators, Operation Pressure, Setting Correct Pressure	Page 5
Product Specifications	Page 6
Depth Adjustment	Page 7
Loading the Tool	Page 8
Tool Operation	Page 9
Maintaining the Pneumatic Tool	Page 11
Troubleshooting	Page 12

SAFETY INSTRUCTIONS

The purpose of safety symbols is to attract our attention to possible dangers. The safety symbols, and the explanations with them, deserve your careful attention and understanding. The symbol warnings do not by themselves eliminate any danger. The instructions and warnings they give are no substitute for proper accidents prevention measures.

 **WARNING:** Be sure to read and understand all safety instruction in this manual, including all safety alert symbols such as "DANGER", "WARNING" and "CAUTION", before using this pneumatic tool.

SYMBOL MEANING



SYMBOL SAFETY ALERT: Indicates DANGER, WARNING, or CAUTION. May be used in conjunction with other symbols or photographs.



DANGER: Failure to obey this safety warning WILL result in death or serious injury to yourself or others. Always follow the safety precaution to reduce the risk of fire and personal injury.



WARNING: Failure to obey this safety warning CAN result in death or serious injury to yourself or others. Always follow the safety precaution to reduce the risk of fire and personal injury.



CAUTION: Failure to obey this safety warning MAY result in personal injury to yourself or others, or property damage. Always follow the safety precaution to reduce the risk of fire and personal injury.

SAFETY INSTRUCTIONS

1. EYE PROTECTION which conforms to ANSI specifications and provides protection against flying particles both from the FRONT and SIDE should ALWAYS be worn by the operator and others in the work area when connecting to air supply, loading, operating or servicing this tool. Eye protection is required to guard against flying fasteners and debris, which could cause severe eye injury.
2. The employer and/or user must ensure that proper eye protection is worn. Eye protection equipment must conform to the requirements of the American National Standards Institute, ANSI Z87.1 and provide both frontal and side protection.
3. NOTE: Non-side shielded spectacles and face shields alone do not provide adequate protection.



CAUTION: Additional Safety Protection will be required in some environments. For example, the working area may include exposure to noise level which can lead to hearing damage. The employer and user must ensure that any necessary hearing protection is provided and used by the operator and others in the work area. Some environments will require the use of head protection equipment. When required, the employer and user must ensure that head protection conforming to ANSI Z89.1 is used.

4. Dress properly. Do not wear loose clothing or jewelry. Contain long hair. Keep your hair, clothing, and gloves away from moving parts.
5. Keep fingers away from trigger when not driving fasteners to avoid accidental firing.
6. Do not overreach. Keep proper footing

and balance at all times. Proper footing and balance enables better control of the tool in unexpected situations.

6. Do not use on a ladder or unstable support. Stable footing on a solid surface enables better control of the tool in unexpected situations.
7. Tool service must be performed only by qualified repair personnel. Service or maintenance performed by unqualified personnel may result in a risk of injury.
8. When servicing a tool, use only identical replacement parts. Use of unauthorized parts may create a risk of injury.
9. Know your pneumatic tool. Read operator's manual carefully. Learn its applications and limitations, as well as the specific potential hazards related to this tool. Following this rule will reduce the risk of electric shock, fire, or serious injury.
10. Always wear safety glasses with side shields. Everyday glasses have only impact resistant lenses. They are NOT safety glasses. Following this rule will reduce the risk of eye injury.
11. Protect your lungs. Wear a face or dust mask if the operation is dusty. Following this rule will reduce the risk of serious personal injury.
12. Protect your hearing. Wear hearing protection during extended periods of operation. Following this rule will reduce the risk of serious personal injury.
13. Make sure the hose is free of obstructions or snags. Entangled or snarled hoses can cause loss of balance or footing and may become damaged.
14. Use the tool only for its intended use. Do not discharge fasteners into open air.
15. Use the MENARDS pneumatic tool only for the purpose for which it was designed.
16. Use only the fasteners recommended for this tool. Use of the wrong fasteners could result in poor fastener feeding, jammed fasteners, and nails leaving the tool at erratic angles. If fasteners are not feeding smoothly and properly, discontinue their use immediately. Jammed and

SAFETY INSTRUCTIONS

improperly feeding fasteners could result in serious personal injury.

17. Never use this tool in a manner that could cause a fastener to be directed toward the user or others in the work area.
18. Do not use the tool as a hammer.
19. Always be aware that misuse and improper handling of this tool can cause injury to yourself and others.
20. Never leave a tool unattended with the air hose attached.
21. Do not operate this tool if it does not contain a legible warning label.
22. Do not continue to use a tool that leaks air or does not function properly.

AIR SUPPLY AND CONNECTION

1. Do not use supply sources which can potentially exceed 200 P.S.I. as tool may burst, possibly causing injury.
2. The connector on the tool must not hold pressure when air supply is disconnected. If a wrong fitting is used, the tool can remain charged with air after disconnecting and thus will be able to drive a fastener even after the air line is disconnected possibly causing injury.
3. Do not pull trigger or depress contact arm while connected to the air supply as the tool may cycle, possibly causing injury.
4. Always disconnect air supply: 1.) Before making adjustments; 2.) When servicing the tool; 3.) When clearing a jam; 4.) When tool is not in use; 5.) When moving to a different work area, as accidental actuation may occur, possibly causing injury.

LOADING TOOL

When loading tool: 1.) Never place a hand or any other part of the body in fastener discharge area of tool; 2.) Never point tool at anyone; 3.) Do not pull the trigger or depress the trip as accidental actuation may occur, possibly causing injury.

OPERATION

1. Always handle the tool with care: 1.) Never engage in horseplay; 2.) Never pull the trigger unless nose is directed toward the work; 3.) Keep others a safe distance from the tool while tool is in operation as accidental actuation may occur, possibly causing injury.
2. The operator must not hold the trigger pulled on contact arm tools except during fastening operation as serious injury could result if the trip accidentally contacted someone or something, causing the tool to cycle.
3. Keep hands and body away from the discharge area of the tool. A contact arm tool may bounce from the recoil of driving a fastener and an unwanted second fastener may be driven possibly causing injury.
4. Check operation of the contact arm mechanism frequently. Do not use the tool if the arm is not working correctly as accidental driving of a fastener may result. Do not interfere with the proper operation of the contact arm mechanism.
5. Do not drive fasteners on top of other fasteners or with the tool at an overly steep angle as this may cause deflection of fasteners which could cause injury.
6. Do not drive fasteners close to the edge of the work piece as the wood may split, allowing the fastener to be deflected possibly causing injury.
7. Do not point the tool toward yourself or anyone whether it contains fasteners or not.
8. Always ensure that the workpiece contact is fully positioned above the workpiece. Positioning the workpiece contact on ly partially above the workpiece could cause the fastener to miss the workpiece completely and result in serious personal injury.

AIR SUPPLY AND CONNECTIONS



WARNING: Do not use oxygen, combustible gases, or bottled gases as a power source for this tool as tool may explode, possibly causing injury. Keep the tool pointed away from yourself and others when connecting air source.

FITTINGS

Install a male plug on the tool which is free flowing and which will release air pressure from the tool when disconnected from the supply source.

HOSES

Air hoses should have a minimum of 150 p.s.i. (10.6 kg/cm²) working pressure rating or 150 percent of the maximum pressure that could be produced in the air system. The supply hose should contain a fitting that will provide "quick disconnecting" from the male plug on the tool.

SUPPLY SOURCE

Use only clean regulated compressed air as a power source for this tool. **NEVER USE OXYGEN, COMBUSTIBLE GASES, OR BOTTLED GASES, AS A POWER SOURCE FOR THIS TOOL AS TOOL MAY EXPLODE.**

REGULATOR

A pressure regulator with an operating pressure of 0 - 125 p.s.i. (0 - 8.79 kg/cm²) is required to control the operating pressure for safe operation of this tool. Do not connect this tool to air pressure which can potentially exceed 200 p.s.i. (14 kg/cm²) as tool may fracture or burst, possibly causing injury.

OPERATING PRESSURE

Do not exceed recommended maximum operating pressure. The air supply must be capable of maintaining the operating pressure at the tool. Pressure drops in supply can reduce the tool's driving power. Refer to "PRODUCT SPECIFICATIONS" for setting the correct operating pressure for the tool.

FILTER

Dirt and water in the air supply are major causes of wear in pneumatic tools. A filter will help to get the best performance and minimum wear from the tool. The filter must have adequate flow capacity for the specific installation. The filter has to be kept clean to be effective in providing clean compressed air to the tool. Consult the manufacturer's instructions on proper maintenance of your filter. A dirty and clogged filter will cause a pressure drop which will reduce the tool's performance.

PRODUCT SPECIFICATIONS

DRIVING POWER	370 in.lbs
FASTENER TYPE	16 GAUGE
FASTENER RANGE	3/4" to 2 1/2"
MAGAZINE CAPACITY	110 NAILS
WEIGHT	3.8 LBS
OPERATION PRESSURE	70 to 120 PSI
AIR INLET	1/4" NPT

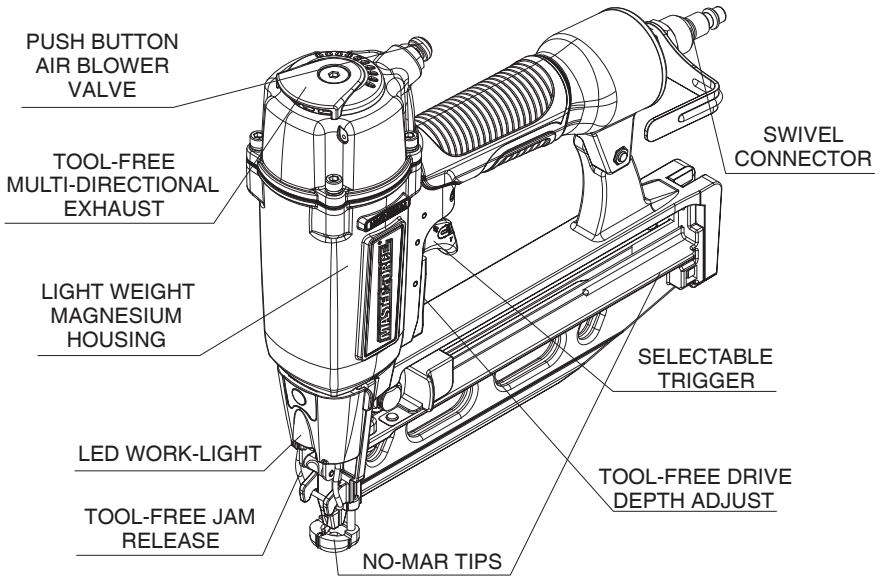

TOOL-FREE MULTI-DIRECTIONAL EXHAUST

The tool-free exhaust can be adjusted to any position depending on operator preference.

SELECTABLE TRIGGER

The selectable trigger lets the operator choose between Contact Actuation and Single Sequential Actuation.

LIGHT WEIGHT MAGNESIUM HOUSING

The light weight magnesium housing helps reduce work fatigue.

TOOL-FREE DRIVE DEPTH ADJUST

The tool-free depth adjustment lets the operator select precise driving depth of the fastener.

TOOL-FREE JAM RELEASE

A tool-free jam release is provided for ease in clearing infrequent jams.

NO-MAR TIPS

The no-mar tips prevent marring and denting when using the tool on softer woods.

SWIVEL CONNECTOR

The swivel connector helps prevent hose tangles.

LED WORK-LIGHT

LED work-light for working in closets and dark spaces.

PUSH BUTTON AIR BLOWER VALVE

Integrated air blower allows user to clear away debris from work surface.

DEPTH ADJUSTMENT

⚠ WARNING:

Always disconnect air supply: 1. Before making adjustments; 2. When servicing the tool; 3. When clearing a jam; 4. When tool is not in use; 5. When moving to a different work area, as accidental actuation may occur, possibly causing injury.

The depth adjustment feature provides close control of the fastener drive depth; from flush with the work surface to shallow or deep countersink. First, set the air pressure for consistent drive in the specific work. Then use the depth adjustment to give the desired depth of drive.

TO ADJUST FASTENER CONTROL ADJUSTMENT:

1. Disconnect the tool from the air supply.
2. Turn the depth selector left or right to change the driving depth.
3. Reconnect the tool to the air supply.
4. Drive a test nail after each adjustment until the desired depth is set.

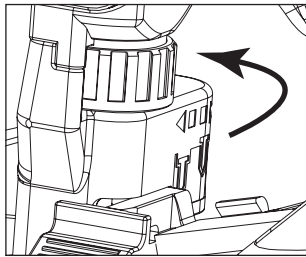

LOADING

TO PREVENT ACCIDENTAL INJURIES:



WARNING:

- Never place a hand or any other part of the body in nail discharge area of tool while the air supply is connected.
- Never point the tool at anyone else.
- Never engage in horseplay.
- Never pull the trigger unless nose is directed at the work.
- Always handle the tool with care.
- Do not pull the trigger or depress the trip mechanism while loading the tool.

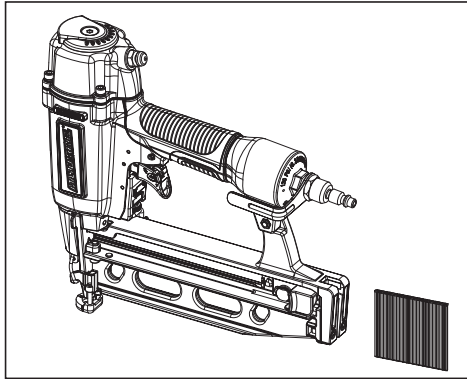

1. Pull the pusher back until it locks into its position. Insert nails into track of magazine.

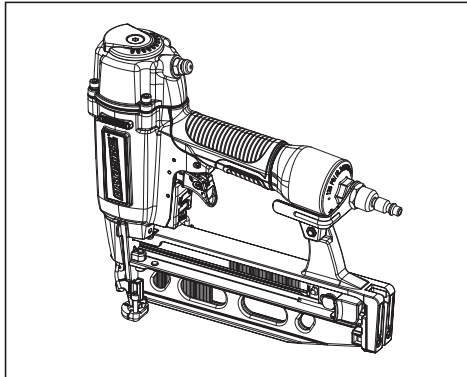

2. Press pusher release to disengage pusher to push nails forward into driving position.

TOOL OPERATION

WARNING:



EYE PROTECTION which conforms to ANSI specifications and provides protection against flying particles both from the **FRONT** and **SIDE** should **ALWAYS** be worn by the operator and others in the work area when connecting to air supply, loading, operating or servicing this tool. Eye protection is required to guard against flying fasteners and debris, which could cause severe eye injury. The employer and/or user must ensure that proper eye protection is worn. Eye protection equipment must conform to the requirements of the American National Standards Institute, ANSI Z87.1 and provide both frontal and side protection.

NOTE: Non-side shielded spectacles and face shields alone do not provide adequate protection.

CAUTION:

Additional Safety Protection will be required in some environments. For example, the working area may include exposure to noise level which can lead to hearing damage. The employer and user must ensure that any necessary hearing protection is provided and used by the operator and others in the work area. Some environments will require the use of head protection equipment. When required, the employer and user must ensure that head protection conforming to ANSI Z89.1 is used.

BEFORE HANDLING OR OPERATING THIS TOOL:

- I. READ AND UNDERSTAND THE WARNINGS CONTAINED IN THIS MANUAL.
- II. REFER TO "TOOL SPECIFICATIONS" IN THIS MANUAL TO IDENTIFY THE OPERATING SYSTEM ON YOUR TOOL.

OPERATION

1. CONTACT TRIP OPERATION:

- A. **SINGLE FASTENER PLACEMENT:** To operate the tool in this manner, first position the contact trip on the work surface, **WITHOUT PULLING THE TRIGGER**. Depress the contact trip until the nose touches the work surface and then pull the trigger to drive a fastener. Do not press the tool against the work with extra force. Instead, allow the tool to recoil off the work surface to avoid a second unwanted fastener. Remove your finger from the trigger after each operation.
- B. **RAPID FASTENER OPERATION:** To operate the tool in this manner, hold the tool with the contact trip pointing towards but not touching the work surface. Pull the trigger and then tap the contact trip against the work surface using a bouncing motion. Each depression of the contact trip will cause a fastener to be driven.

WARNING:

The operator must not hold the trigger pulled on contact trip tools except during fastening operation, as serious injury could result if the trip accidentally contacted someone or something, causing the tool to cycle.

WARNING:

Keep hands and body away from the discharge area of the tool. A contact trip tool may bounce from the recoil of driving a fastener and an unwanted second fastener may be driven, possibly causing injury.

2. SEQUENTIAL TRIP OPERATION:

The **SEQUENTIAL TRIP MODEL** contains a contact trip that operates in conjunction with the trigger to drive a fastener. To operate a sequential trip tool, first position the contact trip on the work surface **WITHOUT PULLING THE TRIGGER**. Depress the contact trip and then pull the trigger to drive a fastener. As long as the contact trip is contacting the work and is held depressed, the tool will drive a fastener each time the trigger is depressed. If the contact trip is allowed to leave the work surface, the sequence described above must be repeated to drive another fastener.

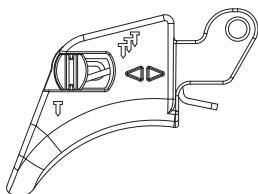

Sequential Trip Operation

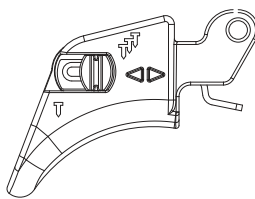

Contact Trip Operation

TOOL OPERATION CHECK



Keep the tool away from yourself and others when connecting air source.



Remove all fasteners from tool before performing tool operation check. To reduce the risk of injury to yourself and others, check the tool before beginning work each day or if the tool is dropped, receive a sharp blow, been run over, etc. If the tool does not work as it should, contact Menards service center immediately.

1. CONTACT TRIP OPERATION:

- A. With finger off the trigger, press the contact trip against the work surface.
THE TOOL MUST NOT CYCLE.
- B. Hold the tool off the work surface, and pull the trigger.
THE TOOL MUST NOT CYCLE.
- C. With the tool off the work surface, pull the trigger. Press the contact trip against the work surface.
THE TOOL MUST CYCLE.
- D. Without touching the trigger, press the contact trip against the work surface, then pull the trigger.
THE TOOL MUST CYCLE.

2. SEQUENTIAL TRIP OPERATION:

- A. Press the contact trip against the work surface, without touching the trigger.
THE TOOL MUST NOT CYCLE.
- B. Hold the tool off the work surface and pull the trigger.
THE TOOL MUST NOT CYCLE.
Release the trigger. The trigger must return to the trigger stop on the frame.
- C. Pull the trigger and press the contact trip against the work surface.
THE TOOL MUST NOT CYCLE.
- D. With finger off the trigger, press the contact trip against the work surface. Pull the trigger.
THE TOOL MUST CYCLE.

IN ADDITION TO THE OTHER WARNINGS CONTAINED IN THIS MANUAL OBSERVE THE FOLLOWING FOR SAFE OPERATION

- Use the Masterforce pneumatic tool only for the purpose for which it was designed.
- Never use this tool in a manner that could cause a fastener to be directed toward the user or others in the work area.
- Do not use the tool as a hammer.
- Always carry the tool by the handle. Never carry the tool by the air hose.
- Always be aware that misuse and improper handling of this tool can cause injury to yourself and others.
- Never clamp or tape the trigger or contact trip in an actuated position.
- Never leave a tool unattended with the air hose attached.
- Do not operate this tool if it does not contain a legible WARNING LABEL.
- Do not continue to use a tool that leaks air or does not function properly.
- Notify Menards service center if your tool continues to experience functional problems.

MAINTAINING THE PNEUMATIC TOOL

WARNING:

When working on air tools, note the warnings in this manual and use extra care evaluating problem tools.

CAUTION:

Pusher spring (constant force spring). Caution must be used when working with the spring assembly. The spring is wrapped around, but not attached to, a roller. If the spring is extended beyond its length, the end will come off the roller and the spring will roll up with a snap, with a chance of pinching your hand. Also the edges of the spring are very thin and could cut. Care must also be taken to insure no permanent kinks are put in the spring as this will reduce the springs force.

REPLACEMENT PARTS:

Masterforce replacement parts are recommended. Do not use modified parts or parts which will not give equivalent performance to the original equipment.

ASSEMBLY PROCEDURE FOR SEALS:

When repairing a tool, make sure the internal parts are clean and lubricated. Use a small amount of oil on all moving surfaces and pivots. After reassembly add a few drops of oil through the air line fitting before testing.

AIR SUPPLY-PRESSURE AND VOLUME:

Air volume is as important as air pressure. The air volume supplied to the tool may be inadequate because of undersize fittings and hoses, or from the effects of dirt and water in the system. Restricted air flow will prevent the tool from receiving an adequate volume of air, even though the pressure reading is high. The results will be slow operation, misfeeds or reduced driving power. Before evaluating tool problems for these symptoms, trace the air supply from the tool to the supply source for restrictive connectors, swivel fittings, low points containing water and anything else that would prevent full volume flow of air to the tool.

CAUTION:

If the tool does not work as it should, contact Menards service center immediately.

LUBRICATION

Frequent, but not excessive, lubrication is required for best performance. Oil added through the air line connection will lubricate the internal parts. Do not use detergent oil or additives as these lubricants will cause accelerated wear to the seals and bumpers in the tool, resulting in poor tool performance and frequent tool maintenance.

If no airline lubricator is used, add oil during use into the air fitting on the tool once or twice a day. Only a few drops of oil at a time is necessary. Too much oil will only collect inside the tool and will be noticeable in the exhaust cycle.

COLD WEATHER OPERATION:

For cold weather operation, near and below freezing, the moisture in the air line may freeze and prevent tool operation. We recommend the use of permanent antifreeze (ethylene glycol) as a cold weather lubricant.

CAUTION:

Do not store tools in a cold weather environment to prevent frost or ice formation on the tools operating valves and mechanisms that could cause tool failure.

NOTE: Some commercial air line drying liquids are harmful to “O”-rings and seals – do not use these low temperature air dryers without checking compatibility.

TROUBLESHOOTING

PROBLEM	CAUSE	CORRECTION
Frame/nose leaks air	Loose nose screws	Tighten and recheck
	O-ring or Gasket is cut or cracked . . .	Replace O-ring or gasket
	Bumper cracked/worn	Replace bumper
Frame/cap leaks air	Damaged gasket or seal	Replace gasket or seal
	Loose cap screws	Tighten and recheck
Failure to cycle	Air supply restriction	Check air supply equipment
	Tool dry, lack of lubrication	Use Lubricant
	Worn head valve O-rings	Replace O-rings
	Head valve stuck in cap	Disassemble/Check/Lubricate
Lack of power; slow to cycle	Tool dry, lacks lubrication	Use Lubricant
	O-rings/seals cut or cracked	Replace O-rings/seals
	Trigger assembly worn/leaks	Replace trigger assembly
	Dirt/tar build up on driver	Disassemble nose/driver to clean
	Cylinder sleeve not seated correctly on bottom bumper	Disassemble to correct
	Head valve dry	Disassemble/lubricate
	Air pressure too low	Check air supply equipment
Skipping fasteners; intermittent feed	Worn bumper	Replace bumper
	Tar/dirt in driver channel	Disassemble and clean nose and driver
	Air restriction/inadequate air flow through quick disconnect socket and plug . . .	Replace quick disconnect fittings
	Worn piston O-ring	Replace O-ring, check driver
	Tool dry, lacks lubrication	Use Lubricant
	Low air pressure	Check air supply system to tool
	Loose magazine nose screws	Tighten all screws
	Fasteners too short for tool	Use only recommended fasteners
	Bent fasteners	Discontinue using these fasteners
	Wrong size fasteners	Use only recommended fasteners
	Leaking head cap gasket	Tighten screws/replace gasket/ O-ring
	Trigger valve O-ring cut/worn	Replace O-ring
	Broken/chipped driver	Replace driver (check piston O-ring)
	Dry/dirty magazine	Clean/lubricate use Lubricant
Fasteners jam in tool	Wrong size fasteners	Use only recommended fasteners
	Bent fasteners	Discontinue using these fasteners
	Loose magazine/nose screws	Tighten all screws
	Broken/chipped driver	Replace driver



STRAIGHT FINISH NAILER WARRANTY

90-DAY MONEY BACK GUARANTEE

This MASTERFORCE® brand power tool carries our 90-DAY Money Back Guarantee. If you are not completely satisfied with your MASTERFORCE® brand power tool for any reason within ninety (90) days from the date of purchase, return the tool with your original receipt to any MENARDS® retail store, and we will provide you a refund - no questions asked.

3-YEAR LIMITED WARRANTY

This MASTERFORCE® brand power tool carries our famous No Hassle 3-Year Limited Warranty to the original purchaser. If, during normal use, this MASTERFORCE® power tool breaks or fails due to a defect in material or workmanship within three (3) years from the date of original purchase, simply bring this tool with the original sales receipt back to your nearest MENARDS® retail store. At its discretion, MASTERFORCE® agrees to have the tool or any defective part(s) repaired or replaced with the same or similar MASTERFORCE® product or part free of charge, within the stated warranty period, when returned by the original purchaser with original sales receipt.

Notwithstanding the foregoing, this limited warranty does not cover any damage that has resulted from abuse or misuse of the Merchandise. This warranty: (1) excludes expendable parts including but not limited to blades, brushes, belts, bits, light bulbs, and/or batteries; (2) shall be void if this tool is used for commercial and/or rental purposes; and (3) does not cover any losses, injuries to persons/property or costs. This warranty does give you specific legal rights and you may have other rights, which vary from state to state. Be careful, tools are dangerous if improperly used or maintained. Seller's employees are not qualified to advise you on the use of this Merchandise. Any oral representation(s) made will not be binding on seller or its employees. The rights under this limited warranty are to the original purchaser of the Merchandise and may not be transferred to any subsequent owner. This limited warranty is in lieu of all warranties, expressed or implied including warranties or merchantability and fitness for a particular purpose. Seller shall not be liable for any special, incidental, or consequential damages. The sole exclusive remedy against the seller will be for the replacement of any defects as provided herein, as long as the seller is willing or able to replace this product or is willing to refund the purchase price as provided above. For insurance purposes, seller is not allowed to demonstrate any of these power tools for you.

For questions / comments, technical assistance or repair parts -
Please Call Toll Free at: **1-888-728-0800** (M-F 8am - 6pm)

**SAVE YOUR RECEIPTS
THIS WARRANTY IS VOID WITHOUT THEM.**

MASTER★FORCE®

MENARDS®

Menards, Inc., Eau Claire, WI 54703

Rev. C 1805